

**PROPER USE GUIDELINES**

Cumulative Trauma Disorders can result from the prolonged use of manually powered hand tools. Hand tools are intended for occasional use and low volume applications. A wide selection of powered application equipment for extended-use, production operations is available.

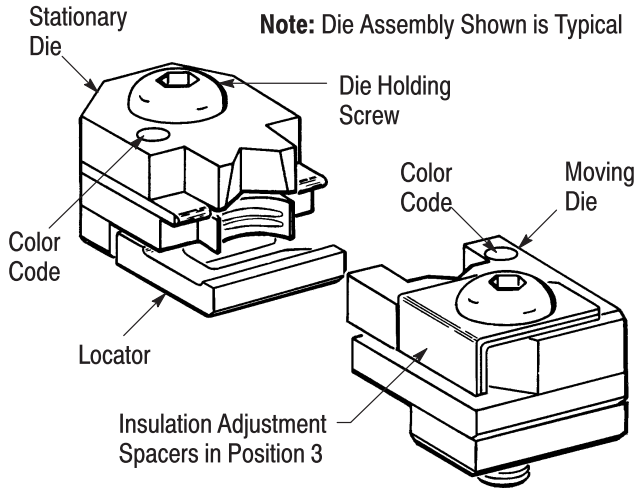

CRIMPING DIE ASSEMBLIES		
46251-2	47808-6	69732
47806-2	69342	69733
47807-1	69344	69734
47808-5	69731	69735

Figure 1

**1. INTRODUCTION**

The die assemblies listed in Figure 1 will crimp terminals and splices for the following product families

with wire sizes 26 through 10 AWG:

- PIDG\* terminals and splices
- PIDG insulation restricting nylon terminals
- PIDG STRATO-THERM\* terminals

with wire sizes 22 through 10 AWG:

- PLASTI-GRIP\* terminals
- DIAMOND GRIP\* terminals and splices

These die assemblies are designed to be used with Hand Tool 69710-1. Refer to Instruction Sheet 408-2095 for information concerning the tool. Contact TOOLING ASSISTANCE CENTER at the number at the bottom of this page for other recommended tooling.

**NOTE** All numerical values in this instruction sheet are in metric units [with U.S. customary units in brackets]. Dimensions are in millimeters [and inches]. Figures are not drawn to scale.

Reasons for reissue of this instruction sheet are provided in Section 7, REVISION SUMMARY.

**2. DESCRIPTION**

The die assembly consists of a moving die and a stationary die. See Figure 1.

The dies and the terminals and splices are color-coded according to wire size for easy identification. When the terminal and splice are properly crimped in the correct die assembly, 1 dot or 2 dots (depending on wire size) will appear embossed on the top and bottom of the terminal or splice. DIAMOND GRIP terminals and splices do not have a color code or crimp dot code. See Figures 2, 3, and 4.

**3. CRIMPING PROCEDURE**

**NOTE** The dies are coated with oil to prevent rust and corrosion. Wipe this oil from the dies, particularly from the crimping area.

1. Install the die assembly according to the instructions included with the tool.

**NOTE** Refer to Paragraph 2.4 for insulation crimp adjustment.

2. Strip the wire to the dimensions provided in Figure 2, 3, 4, or 5; depending on the wire size and product to be crimped.

3. Place the terminal or splice in the stationary die as shown in Figure 6, 7, or 8.

**NOTE** Dies will not accommodate terminals with tongue width exceeding 11.91 [.469].

4. Close the tool handles until the terminal or splice is held firmly in place.

5. For a terminal, insert a stripped wire into the insulation barrel until the wire butts against the locator. For a splice, insert the stripped wire into an insulation barrel until the wire butts against the wire stop in the splice.

6. Complete the crimp by closing the tool handles until the ratchet releases.

**PIDG Terminal and Splice and PLASTI-GRIP Terminal**

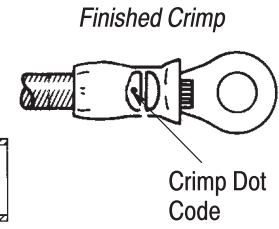
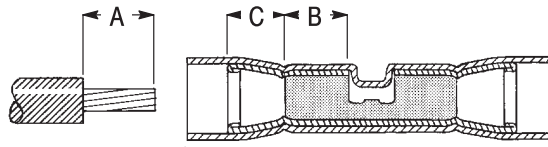
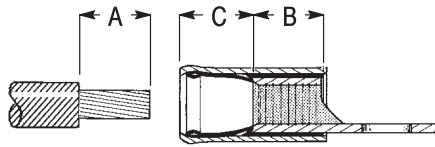

“A” Equals Strip Length      “B” Equals Wire Barrel      “C” Equals Insulation Barrel

DIE ASSEMBLY	WIRE SIZE (AWG) RANGE	COLOR CODE	CRIMP DOT CODE	WIRE STRIP LENGTH			
				TERMINAL		SPLICE	
				MIN	MAX	MIN	MAX
69344	26-22	Yellow	1	3.96 [.156]	4.78 [.188]	4.37 [.172]	5.16 [.203]
69342	24-20	White	2	4.78 [.188]	5.56 [.219]	5.56 [.219]	6.35 [.250]
47806-2	22-16	Red	1	5.16 [.203]	5.94 [.234]	6.35 [.250]	7.14 [.281]
47807-1	16-14 or 20-16 HD	Blue	2				
47808-6●	12-10	Yellow	1	7.95 [.313]	8.74 [.344]	8.74 [.344]	9.52 [.375]
47808-5●	12-10 Lg Exp or 16-14 HD	Yellow	1				

● Use only in Tool 69710-1

Figure 2

**PIDG Insulation Restricting Nylon Terminal**

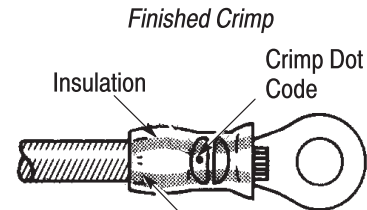
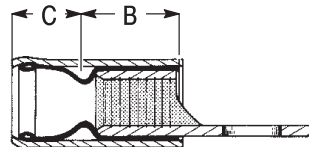
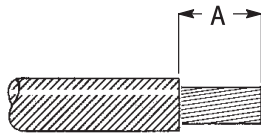

“A” Equals Strip Length      “B” Equals Wire Barrel      “C” Equals Insulation Barrel

3 Equally Spaced Color Stripes

DIE ASSEMBLY	WIRE		COLOR CODE	CRIMP DOT CODE	TERMINAL INSULATION COLOR STRIPE	WIRE STRIP LENGTH	
	SIZE (AWG)	INSULATION DIAMETER RANGE				MIN	MAX
69344	26	0.66-1.40 [.026-.055]	Yellow	1	Black	4.78 [.188]	5.56 [.219]
	24	0.79-1.40 [.031-.055]			Blue		
47806-2	22	0.97-2.79 [.038-.110]	Red	1	Green	6.35 [.250]	7.14 [.281]
	20	1.17-2.79 [.046-.110]			Red		
47807-1	18	1.42-2.79 [.056-.110]	Blue	2	White	6.35 [.250]	7.14 [.281]
	16	1.60-3.30 [.063-.130]			Blue		
47808-6●	14	1.98-3.30 [.078-.130]	Yellow	1	Green	9.52 [.375]	10.31 [.406]
	12	2.41-5.08 [.095-.200]			Yellow		
	10	3.02-5.08 [.119-.200]			Brown		

● Use only in Tool 69710-1

Figure 3

**PIDG STRATO-THERM Terminals**

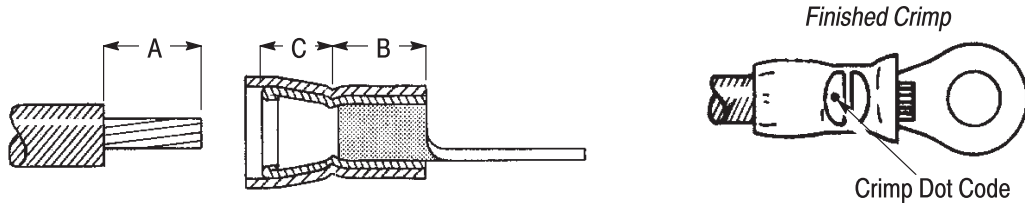

“A” Equals Strip Length      “B” Equals Wire Barrel      “C” Equals Insulation Barrel

DIE ASSEMBLY	WIRE SIZE (AWG) RANGE	COLOR CODE	CRIMP DOT CODE	WIRE STRIP LENGTH	
				MIN	MAX
69731	26-24	Black	1	3.96 [.156]	4.78 [.188]
69732	22-20	Green	2		
69733	18-16	Orange	1	5.16 [.203]	5.94 [.234]
69734	14	White	2		
69735●	12-10	Black	1	7.95 [.313]	8.74 [.344]

● Use only in Tool 69710-1

Figure 4

**DIAMOND GRIP Terminals and Splices**



“A” Equals Strip Length      “B” Equals Wire Barrel      “C” Equals Insulation Barrel

DIE ASSEMBLY	WIRE SIZE (AWG) RANGE	WIRE STRIP LENGTH			
		TERMINAL		SPLICE	
		MIN	MAX	MIN	MAX
46251-2	16-14	4.37 [.172]	5.16 [.203]	5.16 [.203]	5.94 [.234]

● Use only in Tool 69710-1

Figure 5

7. Allow the handles to open fully, and remove the crimped terminal or splice.

8. For a splice, reposition the uncrimped insulation barrel in the stationary die. If the splice cannot be turned, turn the tool. Close the handles until the splice is held firmly in place, insert the stripped wire, and complete the crimp.

**4. INSULATION CRIMP ADJUSTMENT**

**4.1. PIDG Terminals and Splices, PIDG STRATO-THERM Terminals, and DIAMOND GRIP Terminals and Splices**

The insulation barrel crimping section of the moving die has three crimp positions: 1-Tight, 2-Medium, 3-Loose. Adjust the insulation crimp as follows:



**CAUTION** Damaged product should not be used. If a damaged product is evident, it should be cut from the wire and replaced with a new one. DO NOT re-terminate terminals or splices.



**NOTE** PIDG terminals and splices and DIAMOND GRIP terminals and splices feature an “insulation grip”.

1. Turn both insulation crimp adjustment spacers so that they fit into the notch in the side of the die. See Figure 1. This is Position 3 or loose crimp position.

**PIDG Terminal,  
PIDG STRATO-THERM  
Terminal,  
PLASTI-GRIP  
Terminal, and  
DIAMOND GRIP  
Terminal**

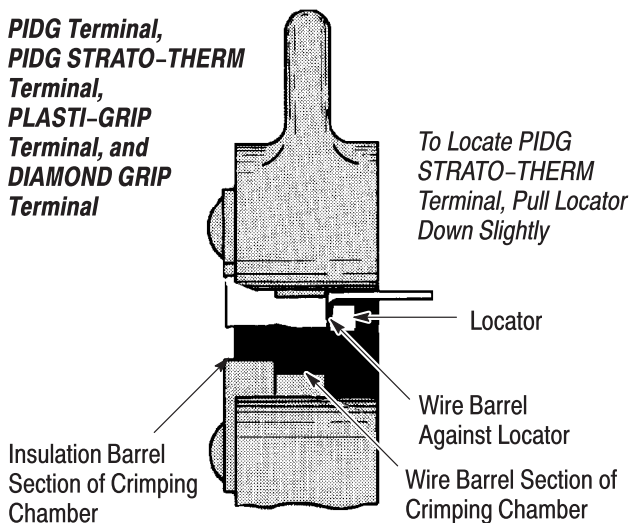

Figure 6

**PIDG Splice**

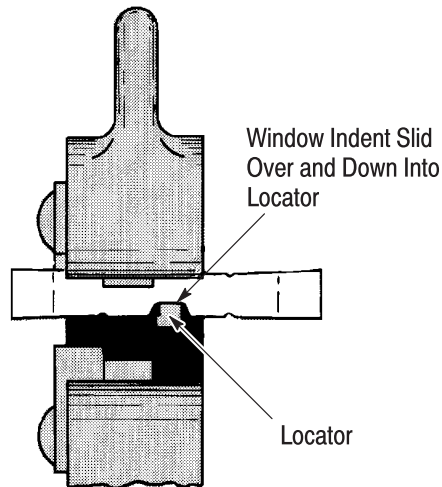

Figure 7

**DIAMOND GRIP  
Splice**

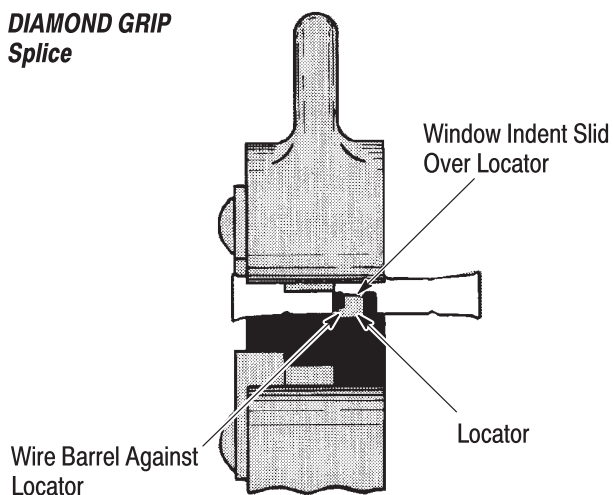

Figure 8

**NOTE**



The moving die must be removed from the die holder to make this adjustment.

2. Insert the moving die into the die holder. Turn the die holding screw enough to hold the die firmly in place. DO NOT tighten the die holding screw at this time.
3. Insert an UNSTRIPPED wire into ONLY the insulation barrel of the terminal or splice.
4. Make a test crimp. Close the moving die on the terminal or splice and hold the moving die in the bottomed position. Tighten the die holding screw while the dies are bottomed, then complete the crimping cycle.
5. Remove the terminal or splice from the dies, and check the insulation grip by bending the wire back and forth ONCE. The terminal sleeve should retain the grip on the wire insulation. If the wire pulls out, set the insulation crimp adjustment to the next tighter position as follows:
  - a. Remove the moving die from the die holder.
  - b. Turn the lower insulation adjustment spacer 90° so that it fits between the moving die and the die holder. Number 2 will appear on the corner of the spacer.
  - c. Repeat the test crimp and adjust the moving die as necessary until the desired insulation grip is obtained.
6. With both adjustment spacers placed between the moving die and the die holder, the die is set in the tightest insulation crimping position. Number 1 will appear on the corner of the top spacer.

#### 4.2. PLASTI-GRIP Terminal

The insulation crimping section of the moving die has three crimp positions: 1-Tight, 2-Medium, 3-Loose. Adjust the insulation crimp as follows:

**NOTE**



PLASTI-GRIP terminals feature a wire insulation support only.

1. Use Position 3 for wire having a large insulation diameter. Remove the moving die from the die holder. Turn both insulation adjustment spacers so that they fit into the notch in the side of the die. See Figure 1.
2. Use Position 2 for wire having a medium insulation diameter. Remove the moving die from the die holder. Turn the lower insulation adjustment spacer 90° so that it fits between the moving die and the die holder. No. 2 will appear on the corner of the spacer nearest the color code dot.

3. Use Position 1 for wire having a small insulation diameter. Turn both insulation adjustment spacers so that they will fit between the moving die and the die holder. No. 1 will appear on the corner of the top spacer nearest the color dot code.

## 5. MAINTENANCE AND INSPECTION

A maintenance and inspection program should be performed periodically. It is recommended that initial frequency of inspection be performed once a month. The frequency of an inspection is dependent upon:

- the care, amount of use, and handling of the dies,
- type and size of the products applied,
- degree of operator skill,
- presence of abnormal amounts of dust and dirt, and
- your own established standards.

Die assemblies are thoroughly inspected before being shipped; however, since there is a possibility of die damage during shipment, it is recommended that dies be inspected by following Section 3 when received.

### 5.1. Cleaning

Do not allow deposits of dirt, grease, and foreign matter to accumulate in the die closure area and on the bottoming surfaces of the dies. These deposits may prevent the dies from bottoming fully and may also cause excessive wear in the die closure surfaces, thereby affecting the quality of the crimp. The dies should be wiped clean frequently with a clean, soft cloth.

### 5.2. Visual Inspection

Visually inspect the die closure surfaces for broken, chipped, or pitted conditions. Although dies may gage within permissible limits, worn or damaged die closure surfaces are objectionable and can affect the quality of the crimp. Examples of possible damaged die surfaces are shown in Figure 9.

### 5.3. Gaging the Crimping Chamber

This inspection requires the use of plug gages conforming to the dimensions provided in Figure 10. To gage the crimping chamber, proceed as follows:

1. Remove traces of oil or dirt from the crimping chamber and plug gage members.
2. Turn both insulation adjustment spacers of the moving die so that they fit into the notch in the side of the die. See Figure 1. The die is now set in the Position 3 (loose). This will provide access to the wire barrel section of the crimping chamber for plug gaging.

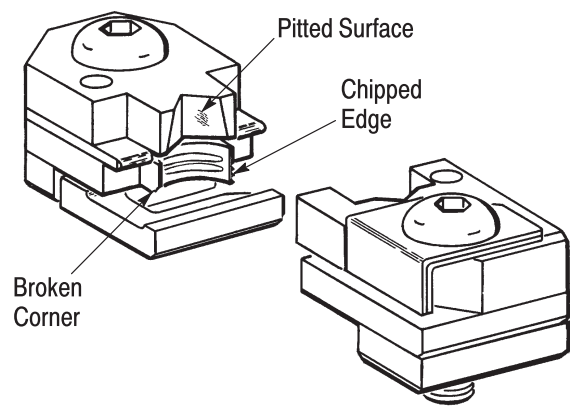

Figure 9

3. Insert both dies in the tool die holders.
4. For the hand tool, close the handles of the tool until the dies bottom. DO NOT apply additional pressure to the tool handles. Actuate the tool until the dies bottom.

#### CAUTION



*If using a pneumatic tool, reduce the air supply pressure to a range between 15 and 20 psi [103.4 and 137.9 kpa] before actuating the tool.*

5. If the position of the locator and the insulation barrel section of the crimping chamber prevent gaging the wire barrel section of the crimping chamber, remove the die assembly from the hand tool, and rotate the locator 180°. This will allow access to the wire barrel section. The die assembly can then be placed in a vise (using light pressure) for gaging.
6. With the wire barrel crimping section of the dies bottomed, check the wire barrel section using the proper plug gage. Hold the gage in a straight alignment with the crimping chamber and carefully try to insert, without forcing the GO member, and then the NO-GO member. See Figure 12, Detail A. The GO member must pass completely through the crimping chamber.
7. The NO-GO member may enter partially, but must not pass completely through the wire barrel section of the crimping chamber. See Figure 12, Detail A.
8. Remove the moving die from the tool die holder.
9. Reposition the insulation adjustment spacers in the No. 1 position. Refer to Paragraph 2.4 for insulation crimp position adjustment procedures.
10. Insert the moving die into the tool die holder.
11. With the wire barrel crimping section of the dies bottomed, check the insulation barrel section of the crimping chamber using the proper plug gage in the same manner as steps 6 and 7. See Figure 12, Detail B.

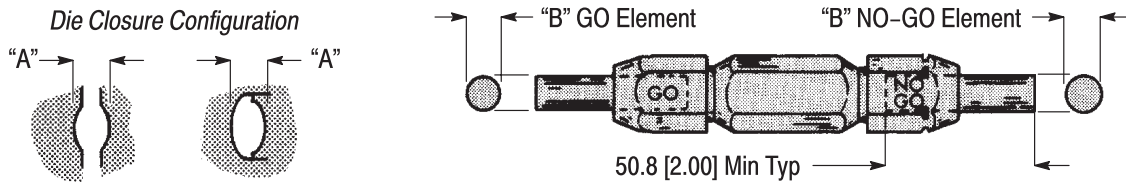

DIE ASSEMBLY	DIE CLOSURE DIM. "A"† (Set Insulation Adjustment Spacers at Position 3)		GAGE MEMBER‡ DIM. "B" DIAMETER	
	GO	NO-GO	GO	NO-GO
46251-2	2.032 [.0800]	2.184 [.0860]	2.032-2.040 [.0800-.0803]	2.182-2.184 [.0859-.0860]
47806-2	2.769 [.1090]	2.921 [.1150]	2.769-2.776 [.1090-.1093]	2.918-2.921 [.1149-.1150]
47807-1	3.023 [.1190]	3.175 [.1250]	3.023-3.030 [.1190-.1193]	3.172-3.175 [.1249-.1250]
47808-5	4.293 [.1690]	4.445 [.1750]	4.293-4.300 [.1690-.1693]	4.442-4.445 [.1749-.1750]
47808-6	4.293 [.1690]	4.445 [.1750]	4.293-4.300 [.1690-.1693]	4.442-4.445 [.1749-.1750]
69342	2.261 [.0890]	2.413 [.0950]	2.261-2.268 [.0890-.0893]	2.410-2.413 [.0949-.0950]
69344	1.600 [.0630]	1.753 [.0690]	1.600-1.608 [.0630-.0633]	1.750-1.752 [.0689-.0690]
69731	2.286 [.0900]	2.388 [.0940]	2.286-2.294 [.0900-.0903]	2.385-2.388 [.0939-.0940]
69732	2.642 [.1040]	2.616 [.1080]	2.642-2.649 [.1040-.1043]	2.741-2.743 [.1079-.1080]
69733	3.302 [.1300]	3.404 [.1340]	3.302-3.310 [.1300-.1303]	3.401-3.404 [.1339-.1340]
69734	3.810 [.1500]	3.912 [.1540]	3.810-3.818 [.1500-.1503]	3.909-3.912 [.1539-.1540]
69735■	4.928 [.1940]	5.029 [.1980]	4.928-4.935 [.1940-.1943]	5.027-5.029 [.1979-.1980]

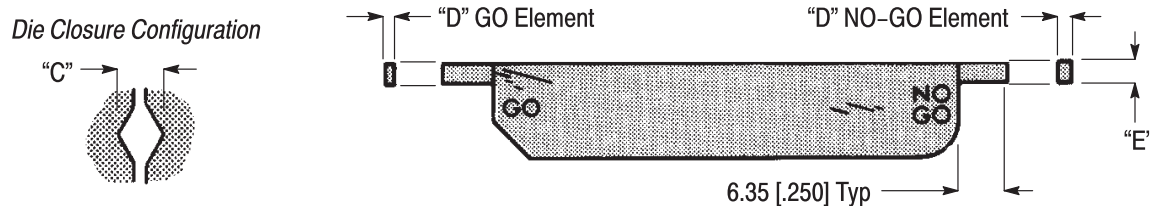

DIE ASSEMBLY	DIE CLOSURE DIM. "C"† (See Insulation Adjustment Spacers at Position 1)		GAGE MEMBER‡ DIM. "D" DIAMETER		DIM. "E" WIDTH (Max)
	GO	NO-GO	GO	NO-GO	
46251-2	0.762 [.0300]	1.270 [.0500]	0.762-0.770 [.0300-.0303]	1.267-1.270 [.0499-.0500]	3.18 [.125]
47806-2	0.762 [.0300]	1.270 [.0500]	0.762-0.770 [.0300-.0303]	1.267-1.270 [.0499-.0500]	3.18 [.125]
47807-1	1.016 [.0400]	1.524 [.0600]	1.016-1.024 [.0400-.0403]	1.521-1.524 [.0599-.0600]	4.75 [.187]
47808-5	1.626 [.0640]	2.134 [.0840]	1.626-1.633 [.0640-.0643]	2.131-2.134 [.0839-.0840]	4.34 [.171]
47808-6	1.626 [.0640]	2.134 [.0840]	1.626-1.633 [.0640-.0643]	2.131-2.134 [.0839-.0840]	4.34 [.171]
69342	0.762 [.0300]	1.270 [.0500]	0.762-0.770 [.0300-.0303]	1.267-1.270 [.0499-.0500]	3.18 [.125]
69344	0.762 [.0300]	1.270 [.0500]	0.762-0.770 [.0300-.0303]	1.267-1.270 [.0499-.0500]	3.18 [.125]
69731	0.762 [.0300]	1.270 [.0500]	0.762-0.770 [.0300-.0303]	1.267-1.270 [.0499-.0500]	3.18 [.125]
69732	0.762 [.0300]	1.270 [.0500]	0.762-0.770 [.0300-.0303]	1.267-1.270 [.0499-.0500]	3.18 [.125]
69733	0.762 [.0300]	1.270 [.0500]	0.762-0.770 [.0300-.0303]	1.267-1.270 [.0499-.0500]	3.18 [.125]
69734	1.016 [.0400]	1.524 [.0600]	1.016-1.024 [.0400-.0403]	1.521-1.524 [.0599-.0600]	4.75 [.187]
69735	1.626 [.0640]	2.134 [.0840]	1.626-1.633 [.0640-.0643]	2.131-2.134 [.0839-.0840]	4.34 [.171]

■ See Paragraph 5.3, Step 5 †Die closure dimensions apply when dies are bottomed, but not under pressure. ‡Material - tool steel.

Figure 10

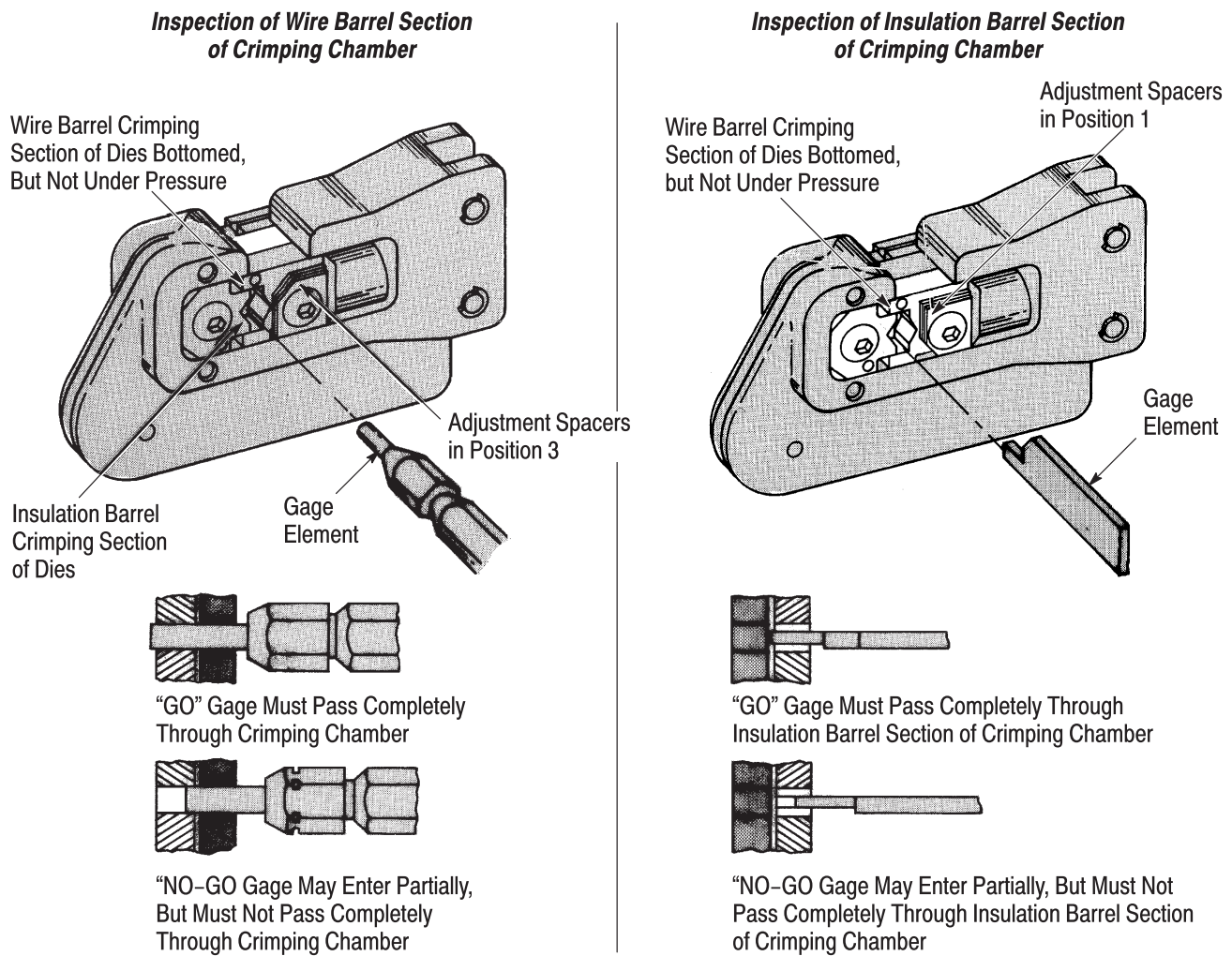

Figure 11

If the crimping chamber conforms to the gage inspection, the dies may be considered dimensionally correct and should be lubricated with a THIN coat of any good SAE 20 motor oil. If the crimping chamber DOES NOT conform to the gage inspection, the dies must be returned for further evaluation and repair.

## 6. REPLACEMENT AND REPAIR

Customer-replaceable parts are listed in Figure 12. A complete inventory should be stocked and controlled to prevent lost time when replacement of parts is necessary. Parts other than those listed should be replaced by Tyco Electronics Corporation to ensure quality and reliability. Order replacement parts through your representative, or call 1-800-526-5142, or send a facsimile of your purchase order to 717-986-7605, or write to:

CUSTOMER SERVICE (038-035)  
 TYCO ELECTRONICS CORPORATION  
 PO BOX 3608  
 HARRISBURG PA 17105-3608

For customer repair service, call 1-800-526-5136.

## 7. REVISION SUMMARY

Revisions to this instruction sheet include:

- Updated document to corporate requirements
- Replaced previous Paragraph 2.5 with Section 2
- Replaced previous Section 2 with Step 1 of Section 3
- Added CAUTION to Step 4 of Section 5

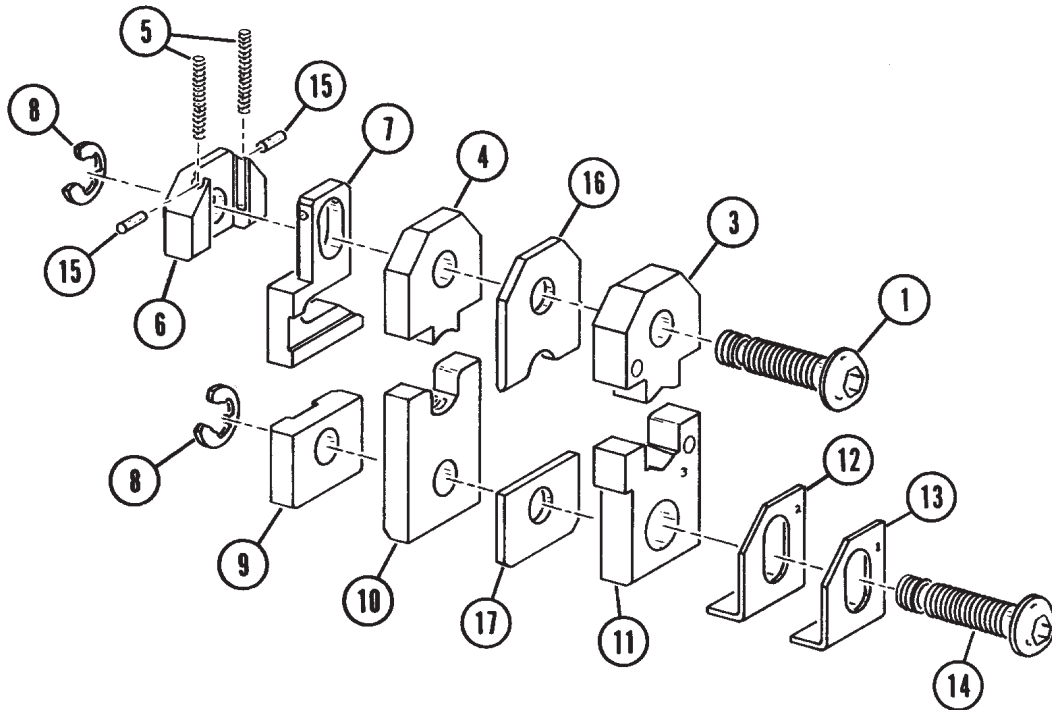

ITEM	DESCRIPTION	PART NUMBER FOR DIE ASSEMBLY			QTY PER DIE ASSEMBLY
		47806-2	47807-1	47808-5	
1	SCREW, Special	2-306131-1	2-306131-1	306105-7	1
3	ANVIL, Insulation	306031-5	306031-4	306031-8	1
4	ANVIL, Wire Barrel	1-306028-2	1-306028-1	2-306028-0	1
5	SPRING	7-59683-4	7-59683-4	7-59683-4	2
6	HOUSING, Locator	2-305832-9	2-305832-9	2-305832-9	1
7	LOCATOR	2-304052-8	2-304052-9	3-304052-0	1
8	RING, Retaining	1-21046-3	1-21046-3	1-21046-3	2
9	SPACER, Lower	2-305832-8	2-305832-8	2-305832-8	1
10	INDENTER, Wire Barrel	1-306029-2	1-306029-1	2-306029-0	1
11	INDENTER, Insulation	306030-5	306030-4	306030-8	1
12	SPACER, Insulation Adjustment	306027-7	306027-7	1-306027-1	1
13	SPACER, Insulation Adjustment	306027-6	306027-6	1-306027-4	1
14	SCREW, Special	306131-9	306131-9	2-306131-5	1
15	PIN, Coiled Spring	21949-1	21949-1	21949-1	2
16	PLATE, Alignment	125152-2	125152-2	125152-8	1
17	SPACER	3-305832-1	3-305832-1	306192-4	1

Figure 12 (Cont'd)



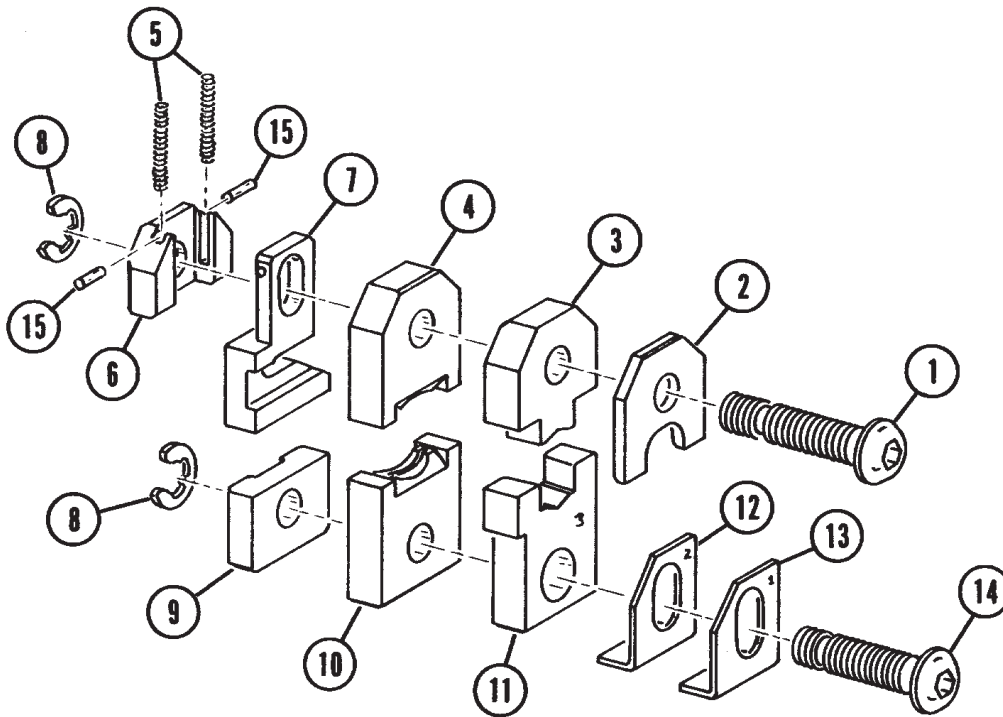

ITEM	DESCRIPTION	PART NUMBER FOR DIE ASSEMBLY 46251-2	QTY PER DIE ASSEMBLY
1	SCREW, Special	3-306624-0	1
2	PLATE, Guide	305549-1	1
3	ANVIL, Insulation	45933-8	1
4	ANVIL, Wire Barrel	306244-6	1
5	SPRING	7-59683-4	2
6	HOUSING, Locator	2-305832-9	1
7	LOCATOR	6-304052-4	1
8	RING, Retaining	1-21046-3	2
9	SPACER, Lower	2-305832-8	1
10	INDENTER, Wire Barrel	306245-2	1
11	INDENTER, Insulation	45970-4	1
12	SPACER, Insulation Adjustment	306027-7	1
13	SPACER, Insulation Adjustment	306027-6	1
14	SCREW, Special	306131-9	1
15	PIN, Coiled Spring	21949-1	2

Figure 12 (Cont'd)

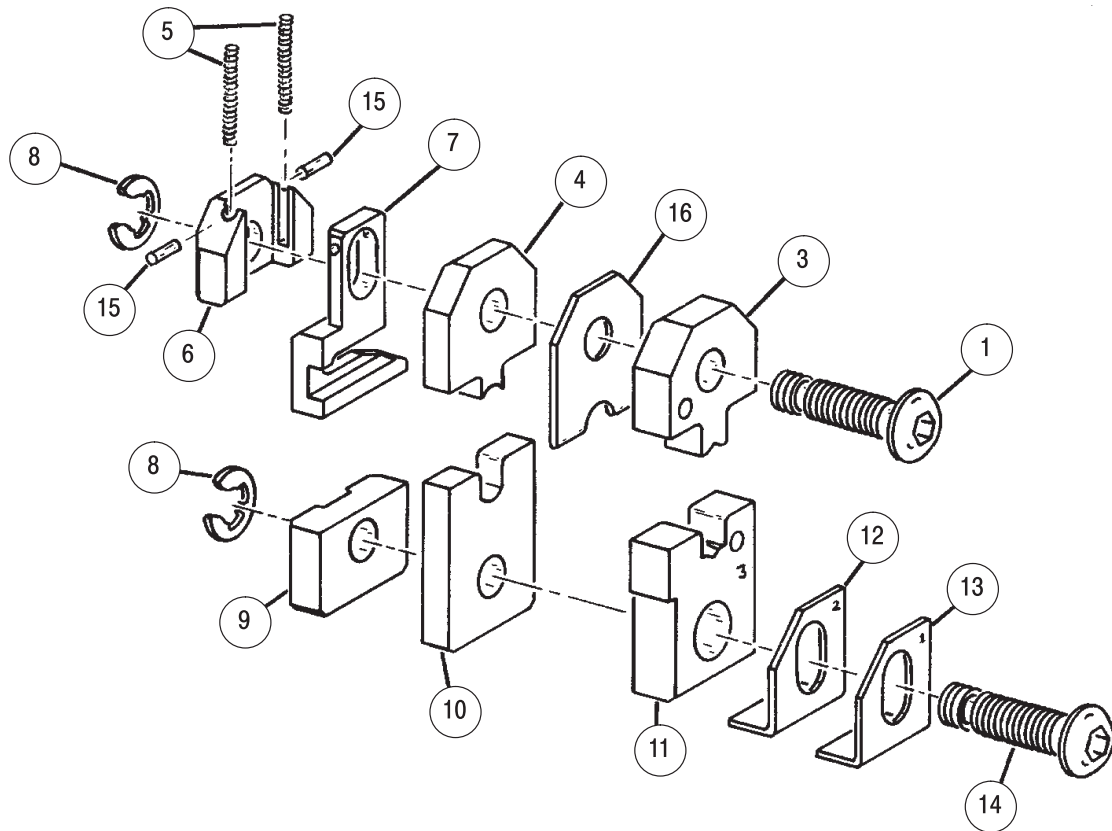

ITEM	DESCRIPTION	PART NUMBER FOR DIE ASSEMBLY			QTY PER DIE ASSEMBLY
		47808-6	69342	69344	
1	SCREW, Special	2-306131-2	306105-9	1-306131-1	1
3	ANVIL, Insulation	1-45932-9	2-45932-0	59628-3	1
4	ANVIL, Wire Barrel	2-306028-0	3-45904-3	2-45904-3	1
5	SPRING	7-59683-4	7-59683-4	7-59683-4	2
6	HOUSING, Locator	2-305832-9	2-305832-9	2-305832-9	1
7	LOCATOR	3-304052-0	3-304052-1	2-304052-6	1
8	RING, Retaining	1-21046-3	1-21046-3	1-21046-3	2
9	SPACER, Lower	2-305832-8	2-305832-8	2-305832-8	1
10	INDENTER, Wire Barrel	2-306029-0	1-45907-6	1-306029-0	1
11	INDENTER, Insulation	306030-6	306030-1	306030-2	1
12	SPACER, Insulation Adjustment	1-306027-0	306027-1	306027-1	1
13	SPACER, Insulation Adjustment	306027-9	306027-2	306027-2	1
14	SCREW, Special	306105-7	2-306131-1	1-306131-1	1
15	PIN, Coiled Spring	21949-1	21949-1	21949-1	2
16	PLATE, Alignment	125152-3	125152-3	125152-3	1

Figure 12 (Cont'd)

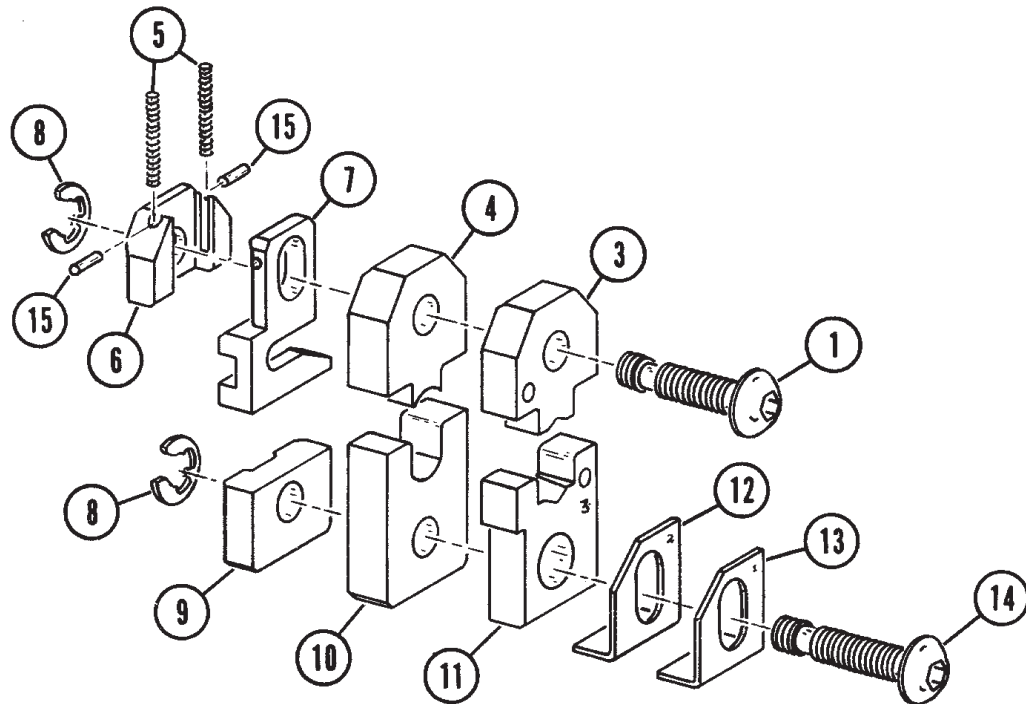

ITEM	DESCRIPTION	PART NUMBER DIE ASSEMBLY					QTY PER DIE ASSEMBLY
		69731	69732	69733	69734	69735	
1	SCREW, Special	3-306131-3	2-306131-1	1-306131-6	1-306131-6	3-306131-4	1
3	ANVIL, Insulation	2-45932-8	1-45932-6	1-45932-7	1-45932-8	1-45932-9	1
4	ANVIL, Wire Barrel	3-45904-1	1-45904-8	1-45904-9	2-45904-0	2-45904-1	1
5	SPRING	7-59683-4	7-59683-4	7-59683-4	7-59683-4	7-59683-4	2
6	HOUSING, Locator	2-305832-9	2-305832-9	2-305832-9	2-305832-9	2-305832-9	1
7	LOCATOR	59737-2	59737-2	59737-3	59737-4	59737-5	1
8	RING, Retaining	1-21046-3	1-21046-3	1-21046-3	1-21046-3	1-21046-3	2
9	SPACER, Lower	2-305832-8	2-305832-8	2-305832-8	2-305832-8	2-305832-8	1
10	INDENTER, Wire Barrel	1-45907-5	1-45907-0	1-45907-1	1-45907-2	1-45907-3	1
11	INDENTER, Insulation	2-45931-7	2-45931-1	2-45931-2	2-45931-3	2-45931-4	1
12	SPACER, Insulation Adjustment	1-306027-6	1-306027-6	306027-7	306027-7	1-306027-0	1
13	SPACER, Insulation Adjustment	1-306027-5	1-306027-5	306027-6	306027-6	306027-9	1
14	SCREW, Special	1-306131-1	1-306131-6	1-306105-1	1-306105-1	2-306131-3	1
15	PIN, Coiled Spring	21949-1	21949-1	21949-1	21949-1	21949-1	2

Figure 12 (End)