

PROPER USE GUIDELINES

Cumulative Trauma Disorders can result from the prolonged use of manually powered hand tools. Hand tools are intended for occasional use and low volume applications. A wide selection of powered application equipment for extended-use, production operations may be available.

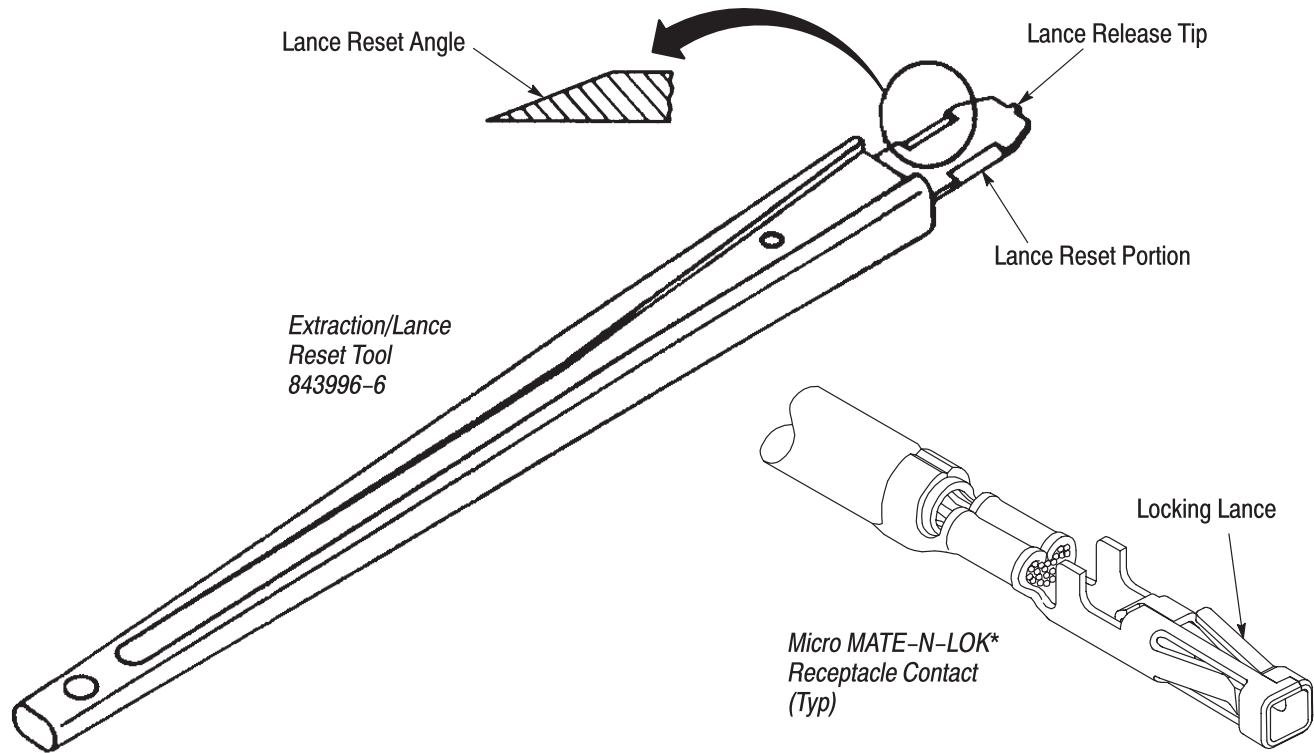

Figure 1

1. INTRODUCTION

This instruction sheet describes the use of Extraction/Lance Reset Tool 843996-6. This tool is designed to remove Micro MATE-N-LOK Receptacle Contacts from housings and reset the overly depressed contact locking lance of the removed contact. (see Figure 1).

Read these instructions thoroughly before attempting to remove any contacts or resetting the locking lances.

NOTE All dimensions are in millimeters (followed by inches in brackets). Figures and illustrations are for reference only, and are not drawn to scale.

2. DESCRIPTION

The tool features a handle marked with the part number, a contact lance release tip, a locking lance reset portion, and a tool stop. The contact lance release tip depresses the contact locking lance to

allow extraction of the contact. The tool stop prevents over-insertion of the tip. The lance reset portion repositions an overly depressed locking lance to the proper height — assuring retention of the contact in the housing.

3. EXTRACTION PROCEDURE (Figure 2A)

Proceed as follows:

1. While holding the connector, grasp the wire at the rear of the housing, and push forward toward the mating end to disengage the contact locking lance from the connector cavity shoulder.
2. Fully insert the extraction tool tip into the window adjacent to the circuit cavity until it bottoms inside the window.
3. Pull back lightly on the wire and, if necessary, move tool just enough to release the lance.
4. Remove the contact from the housing; then remove the tool.

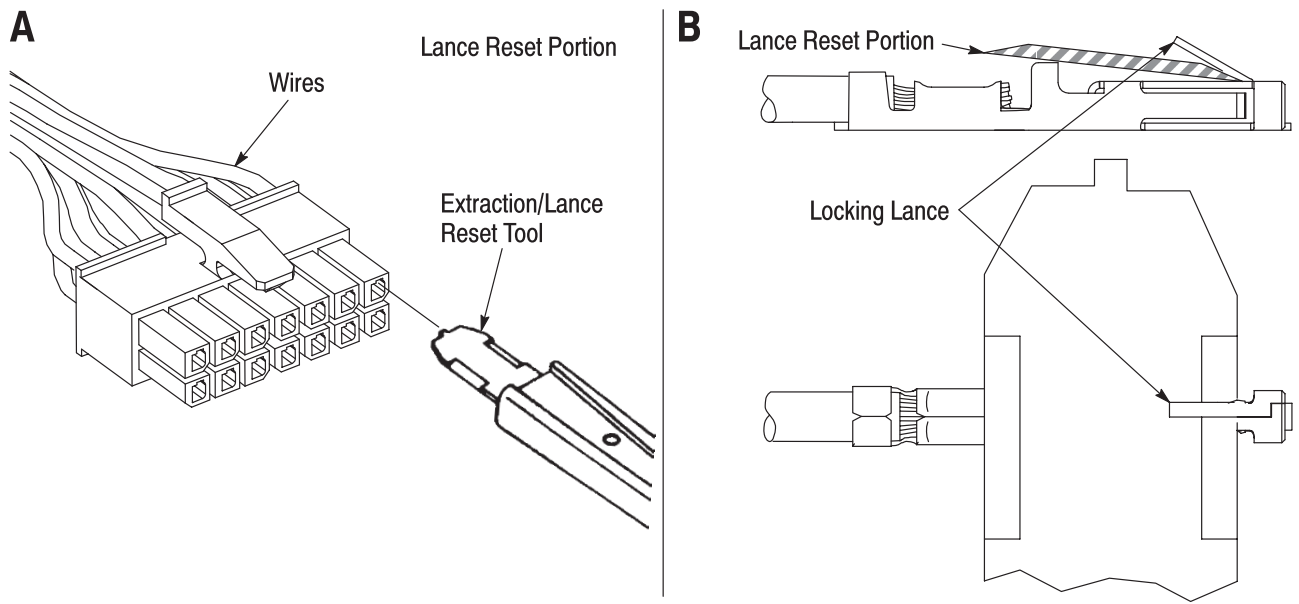

Figure 2

4. LOCKING LANCE RESET PROCEDURE (Figure 2B)

The tools described on this sheet are designed to reposition depressed locking lances to ensure retention in the housing. Check compatibility of the contact and tool; then proceed as follows:

1. Orient the reset tip so the taper is facing the locking lance.
2. Keep the reset tip against the contact and slide it towards the base of the locking lance until it bottoms.
3. Remove tool tip and contact will be ready for re-insertion into the housing.

CAUTION

Damaged contacts should not be used. If a damaged contact is evident, it should be cut from the wire and replaced with a new one.

5. TOOL INSPECTION/MAINTENANCE

Tool 843996-6 should conform to the dimensions provided in Figure 3. It is recommended that each tool be inspected upon its arrival to be sure it has not been damaged in transit and at regularly scheduled intervals to be sure it remains functional.

6. REVISION SUMMARY

- Initial release of document

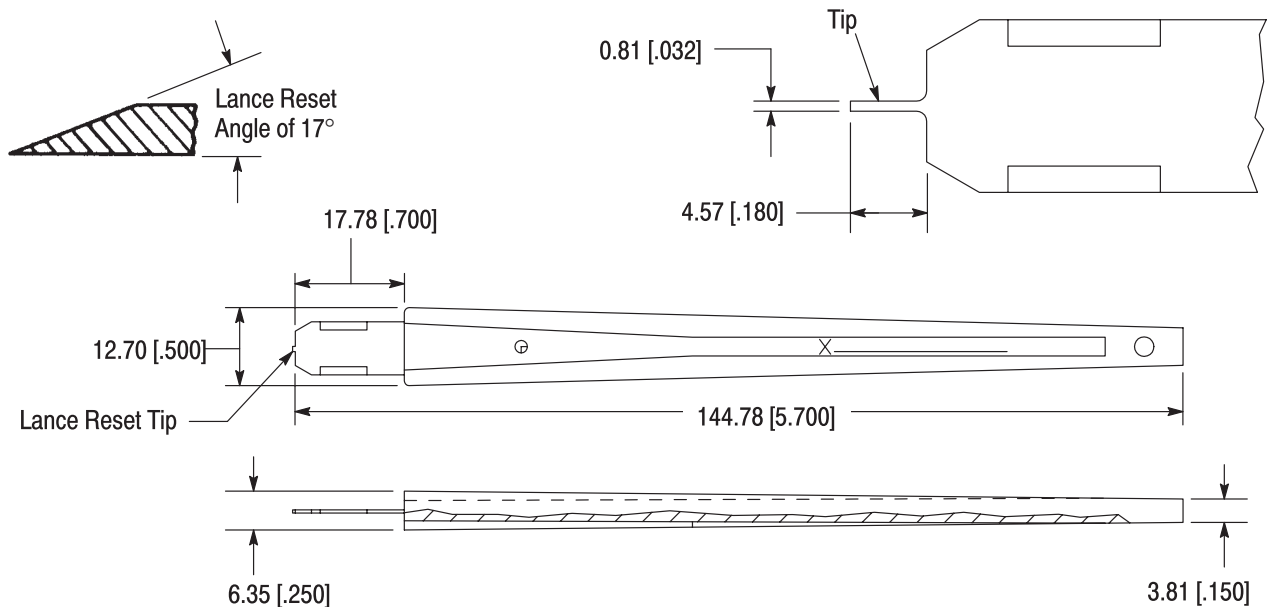

Figure 3