

PART NUMBER	REV	FIRST USED
466323-1	C	122500-1
466323-2	E	565435-5
466323-3	T	122500-1
466323-4	T	565435-5
466323-5		
466323-6	T	354500-1
7-466323-7	P	

SUPERSEDED BY -3
 SUPERSEDED BY -4
 SEE 466323-5

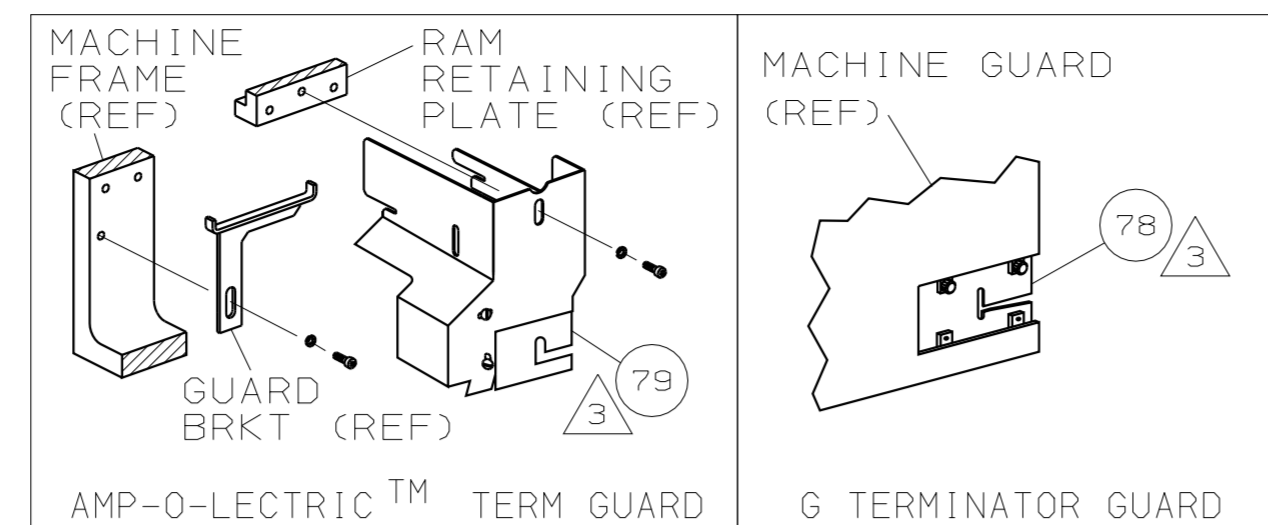

SOCKET		PIN		CRIMPING DATA		
PAD	LTR	CRIMP HEIGHT	WIRE SIZE			
A		.042 ± .002 [1.07 ± 0.05mm]	20			
B		.040 ± .002 [1.02 ± 0.05mm]	(2) 24			
C		.038 ± .002 [0.96 ± 0.05mm]	22			
D		.036 ± .002 [0.91 ± 0.05mm]	24			
CRIMP	SIZE	TYPE	RANGE			
WIRE	.062 [1.57mm]	F	24 - 20			
INSUL	.090 [2.29mm]	0	.040 - .080			
WIRE STRIP LENGTH	TERM APPL SPEC	FEED	APPL INSTRUCTION	SET UP GAGE	LAYOUT	
.134-.164	114-10004	.500	408-8040	458637-1	162	

LEADMAKER		MECH POST FEED		-77 SPARE TOOLING KIT	
BENCH MODEL K		MECH PRE FEED			
BENCH MODEL G		MECH PRE FEED			
-3	REF	REF	- B	22594-8	NUT, HEX (1/2-20)
-4	REF	REF	- B	240628-1	PLATE, ADJUSTMENT
-6	REF	REF	- B	240626-1	SHAFT, PIVOT
-	REF	REF	- B	240633-1	BUSHING
-	REF	REF	- A	455680-1	LEVER, INTERMEDIATE
-	REF	REF	- B	240629-1	BLOCK, PIVOT
-	REF	REF	- A	240632-2	SCREW, ADJ FEED ROD
-	REF	REF	- B	240659-3	PIN, CAM ROLLER
-	REF	REF	- B	240658-1	ROLLER, CAM
-	REF	REF	- B	454398-2	ROD, FEED
-	REF	REF	- A	454178-1	GUIDE, FEED ROD
-	REF	REF	- C	454220-1	CAP, RAM
-	REF	REF	- D	454485-1	HOUSING

THIS DRAWING IS A CONTROLLED DOCUMENT.

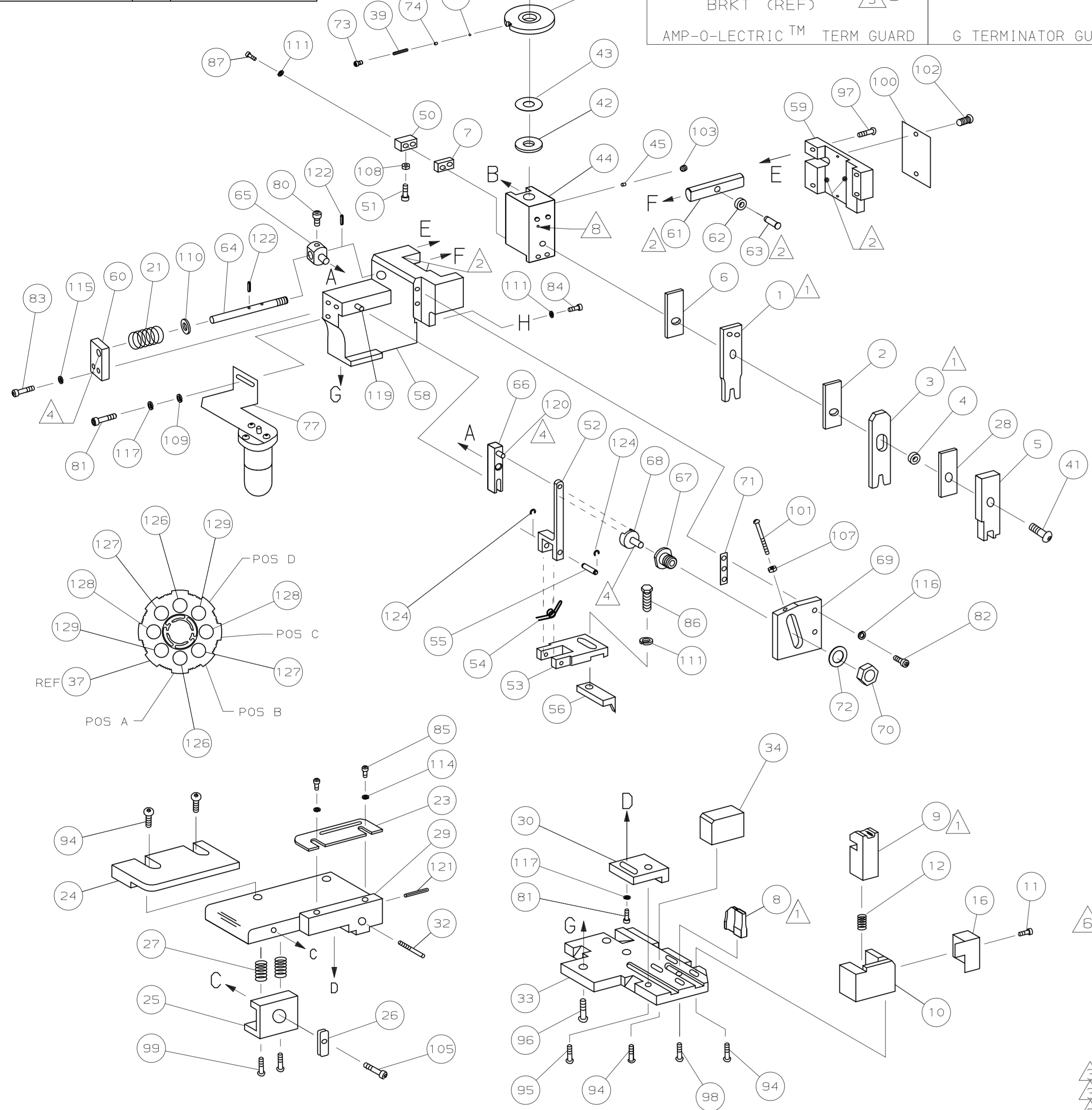

QTY	SOCKET	PIN	DESCRIPTION	ITEM NO
- 2	2	2	- C 5-354779-0 PIN, WIRE DISC (.3240)D	129
- 2	2	2	- C 4-354779-6 PIN, WIRE DISC (.3220)C	128
- 2	2	2	- C 4-354779-2 PIN, WIRE DISC (.3200)B	127
- 2	2	2	- C 3-354779-8 PIN, WIRE DISC (.3180)A	126
- 1	1	1	- A 986950-1 WASHER, FLAT PRECISION	125
- REF	REF	REF	- A 21045-3 RING, RET "C" (Ø.187)FD FING PIN	124
- REF	REF	REF	- A 5-21028-1 PIN, SLT SPR (Ø.125x.50)ADJ ROD	123
- 1	1	1	- A 4-21028-0 PIN, SLT SPR (Ø.093x.75)ST GDE PL	121
- REF	REF	REF	- A 1-21030-1 PIN, DOWEL (Ø.187x.50)LEVER	120
- REF	REF	REF	- A 1-21030-6 PIN, DOWEL (Ø.187x1.25)HOUSING	119
- 1	2	1	- A 21024-5 WASHER, LOCK (#10)ADJ BLOCK	118
- REF	REF	REF	- A 21024-5 WASHER, LOCK (#10)ADJ PLATE	117
- REF	REF	REF	- A 21024-5 WASHER, LOCK (#10)FEED GDE ROD	116
- 2	2	2	- A 21024-2 WASHER, LOCK (#4)FRONT STP GUIDE	114
- 4	4	4	- A 21024-4 WASHER, LOCK (#8)STRIPPER	111
- REF	REF	REF	- A 21899-4 WASHER, FLAT (Ø5/16)SCREW ADJ	110
- 1	1	1	- A 21899-2 WASHER, FLAT (NO. 10)LUB ASSY	109
- 1	1	1	- A 21018-5 NUT, HEX (NO. 6)HOLDDOWN	108
- REF	REF	REF	- A 21018-5 NUT, HEX (6-32)FEED ADJ	107
- 1	1	1	- A 22353-8 SCR, SHLD (Ø.187x.25)DRAG LEVER	105
- 1	1	1	- A 21009-2 SCR, SKT SET (1/4-20x.25 LW)RAM	103
- 2	2	2	- A 21017-2 SCR, DRIVE (#2x.19)ID PLATE	102
- REF	REF	REF	- A 6-23715-5 SCR, PAN HD (6-32x1.50)FEED ADJ	101
- 1	1	1	- B 461264-1 PLATE, IDENTIFICATION	100
- 2	2	2	- A 3-21002-0 SCR, BHC (10-32x.88)DRAG	99
- 1	1	1	- A 22733-8 SCR, BHC (8-32x.38 LW)ANVIL	98
- REF	REF	REF	- A 2-21002-9 SCR, BHC (10-32x.75)CAP	97
- REF	REF	REF	- A 2-22733-8 SCR, BHC (1/4-20x.62)HOUSING	96
- REF	REF	REF	- A 2-21002-7 SCR, BHC (10-32x.50)SG ADJ BLOCK	95
- 6	6	6	- A 2-21002-2 SCR, BHC (8-32x.50)TERM H DWN	94
- 1	1	1	- A 1-21002-7 SCR, BHC (6-32x.38)CAM	91
- 2	2	2	- A 3-21000-0 SCR, SHC (8-32x.86)DEP-HOLD	87
- 1	1	1	- A 2-22603-0 SCR, HEX HD (8-32x.31)FEED FINGER	86
- 2	2	2	- A 1-21000-3 SCR, SHC (4-40x.25)F ST GUIDE	85
- 1	1	1	- A 2-21000-7 SCR, SHC (8-32x.50)STRIPPER	84
- REF	REF	REF	- A 3-21000-7 SCR, SHC (10-32x.75)FEED ROD GD	83
- REF	REF	REF	- A 3-21000-6 SCR, SHC (10-32x.62)FD ADJ BLK	82
- 1	2	1	- A 3-21000-4 SCR, SHC (10-32x.38)SG ADJ BL	81
- REF	REF	REF	- A 3-21000-4 SCR, SHC (10-32x.38)PIVOT BLK	80
- REF	REF	REF	- B 455749-1 GUARD, WINDOW	79
- REF	REF	REF	- B 679532-1 INSERT, GUARD	78
- 1	1	1	- C 1-465184-0 LUBRICATOR ASSY	77
- 1	1	1	- A 690603-1 SPRING, ASSIST	74
- 1	1	1	- A 23030-1 SCR, SHC (6-32x.25 SL)INS DISC	73
- REF	REF	REF	- A 458109-1 WASHER, SPECIAL	72
- REF	REF	REF	- A 690517-1 SPACER	71
-77	-6	-4	-3 U/M DWG SIZE	

QTY	SOCKET	PIN	DESCRIPTION	ITEM NO
- 1	1	1	- B 458537-2 PAWL, FEED	56
- REF	REF	REF	- B 240624-1 PIN, FEED FINGER	55
- REF	REF	REF	- B 691499-1 SPRING, FEED FINGER	54
- REF	REF	REF	- B 690541-1 HOLDER, FEED FINGER	53
- REF	REF	REF	- A 455679-1 LEVER, TERMINAL FEED ARM	52
- 1	1	1	- A 811242-2 BUMPER, HOLDDOWN	51
- 1	1	1	- A 690753-1 SPACER, TONKER	50
- 1	-	-	- B 690602-6 CAM, PRE-FEED 1 5/8 ST	49
- -	-	-	- B 690602-5 CAM, PRE-FEED 1 1/8 ST	48
- -	-	-	- B 690501-4 CAM, POST-FEED 1 5/8 ST	47
- 1	1	1	- B 459456-1 APPLICATOR, BASIC (SUBASSY)	46
- 1	1	1	- A 690191-1 PLUG, NYLON	45
- 1	1	1	- C 455673-1 RAM	44
- 1	1	1	- A 690125-1 WASHER, LAMINATED	43
- 1	1	1	- A 690124-1 WASHER, RAM	42
- 1	1	1	- A 7-21002-9 BOLT, CRIMPER (5/16x1.00)	41
- 1	1	1	- A 23241-6 BALL, STEEL	40
- 1	1	1	- A 690170-1 SPRING, COMPRESSION	39
- 1	1	1	- C 690142-1 DISC, INSULATION	38
- 1	1	1	- D 354777-1 WIRE DISC, PLASTIC	37
- 1	1	1	- A 22480-5 WASHER, SPRING	36
- 1	1	1	- B 690212-1 POST, RAM	35
- 1	1	1	- B 692776-1 SUPPORT, TERMINAL	34
- REF	REF	REF	- D 455675-1 PLATE, BASE	33
- 1	1	1	- A 690432-3 SCREW, ADJUSTMENT	32
- REF	REF	REF	- B 455689-1 BLOCK, STRIP GUIDE ADJ	30
- 1	1	1	- C 458144-1 PLATE, STRIP GUIDE	29
- 1	1	1	- C 1-455888-0 SPACER, FRONT SHEAR DEP	28
- 2	2	2	- A 1-22284-0 SPRING, DRAG	27
- 1	1	1	- B 240793-1 LEVER, DRAG	26
- 1	1	1	- B 240792-1 DRAG, TERMINAL	25
- 1	1	1	- D 90765-4 GUIDE, STRIP (REAR)	24
- 1	1	1	- A 690438-1 GUIDE, STRIP (FRONT)	23
- -	-	-	- B 690472-2 STRIPPER	22
- REF	REF	REF	- A 4-22284-9 SPRING, FEED RETURN	21
- 1	1	-	- B 691353-1 STRIPPER	20
- 1	1	1	- B 691667-1 GUARD, CHIP (FRONT)	16
- 1	1	1	- A 3-22280-3 SPRING, SHEAR	12
- 1	1	1	- B 690461-1 STOP, SHEAR	11
- 1	1	1	- C 690459-1 HOLDER, SHEAR (FRONT)	10
- 1	1	1	- C 454276-1 SHEAR, FLOAT (FRONT)	9
1	1	1	- C 8-458834-6 ANVIL	8
- 1	1	1	- C 5-240641-1 SPACER, DEPRESSOR (REAR)	7
- 1	1	1	- C 455888-1 SPACER, CRIMPER	6
- 1	1	1	- C 1-455889-4 DEPRESSOR, SHEAR (FRONT)	5
- 1	1	1	- B 2-238011-2 SPACER, BLOCK CRIMPER	4
1	1	1	- C 4-456135-4 CRIMPER, INSULATION	3
- 1	1	1	- C 455888-2 SPACER, CRIMPER	2
1	1	1	- C 2-456403-0 CRIMPER, WIRE	1

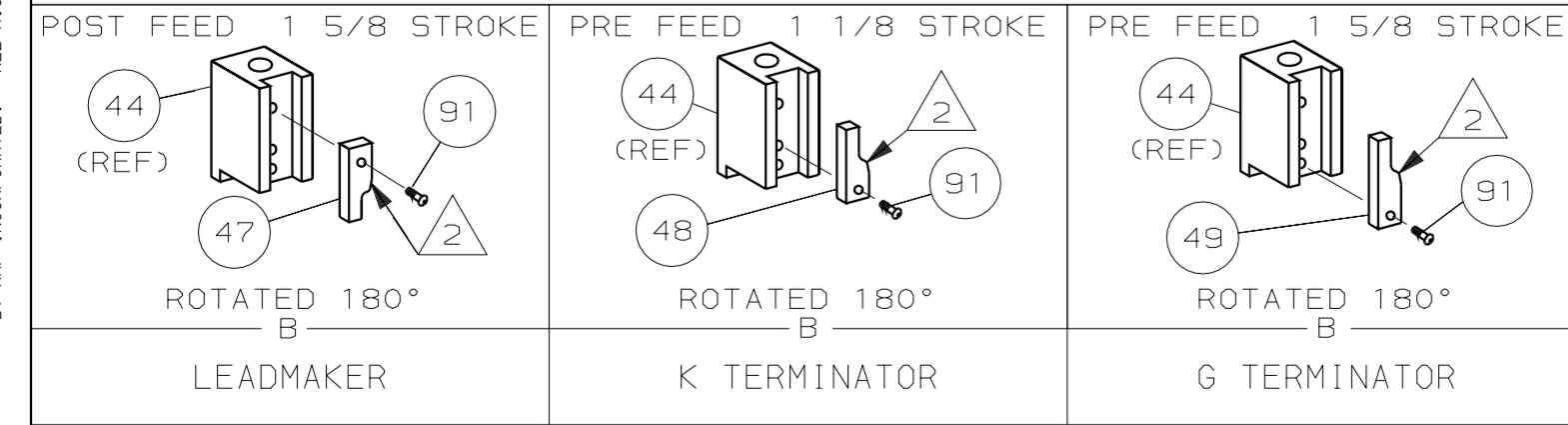

- 1 RECOMMENDED SPARE PARTS.
- 2 GREASE LIGHTLY.
- 3 GUARD MUST BE IN PLACE WHEN OPERATING APPLICATOR IN A BENCH MACHINE.
- 4 LUBRICATE DAILY USING NO. 20 MACHINE OIL.
- 5. ITEMS WITH QTY OF REF SPECIFIED (EXCEPT ITEMS 78 AND 79) ARE USED ON ITEM 46.
- 6 CUT TO LENGTH AT ASSY
- 7 LUBRICATION REQUIRED WHEN USING GOLD PLATED, SILVER PLATED, NICKEL PLATED, OR STAINLESS STEEL TERMINALS.
- 8 REMOVE PIN DURING ASSEMBLY

LOC	DIST	DESCRIPTION
A	66	LEADMAKER & BENCH MACHINE