

**PROPER USE GUIDELINES**

Cumulative Trauma Disorders can result from the prolonged use of manually powered hand tools. Hand tools are intended for occasional use and low volume applications. A wide selection of powered application equipment for extended-use, production operations is available.

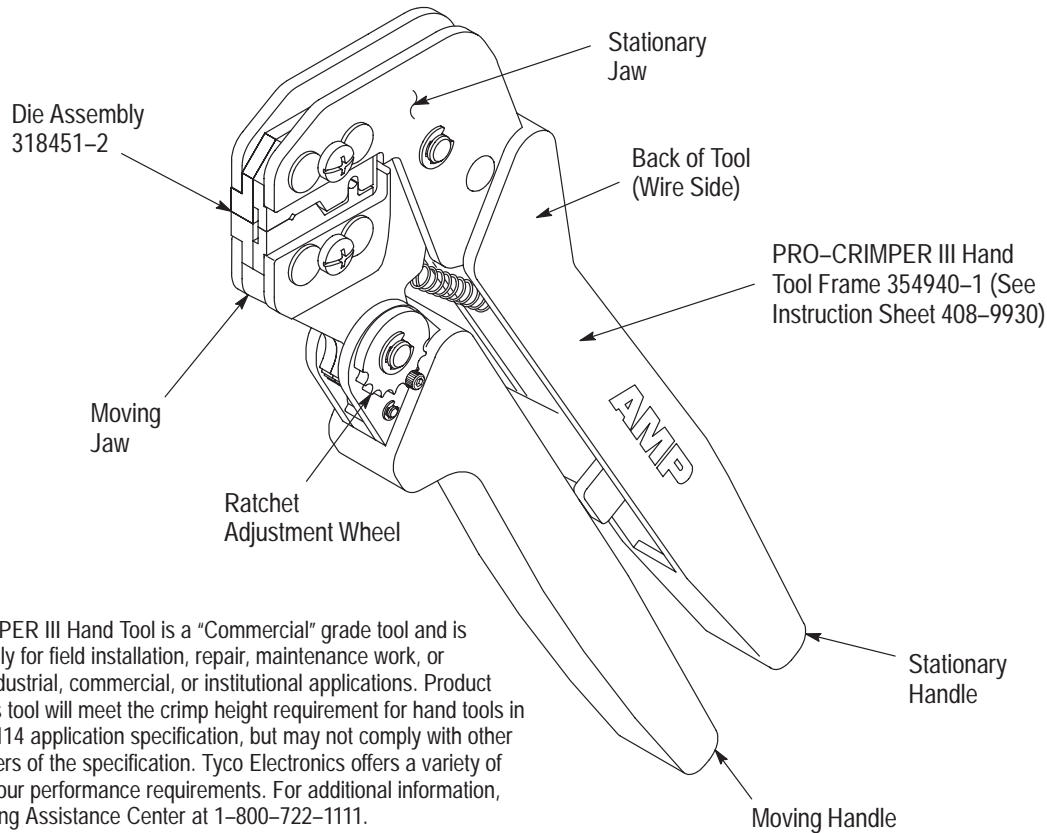

The PRO-CRIMPER III Hand Tool is a "Commercial" grade tool and is designed primarily for field installation, repair, maintenance work, or prototyping in industrial, commercial, or institutional applications. Product crimped with this tool will meet the crimp height requirement for hand tools in the appropriate 114 application specification, but may not comply with other feature parameters of the specification. Tyco Electronics offers a variety of tools to satisfy your performance requirements. For additional information, contact the Tooling Assistance Center at 1-800-722-1111.

Figure 1

**1. INTRODUCTION**

PRO-CRIMPER III Hand Tool Assembly 318451-1 consists of Die Assembly 318451-2 and PRO-CRIMPER III Hand Tool Frame 354940-1. The hand tool assembly is used to crimp 75-Ohm RF Series BNC Commercial Plug Connector 221185-8 and Bulkhead Jack Connector 221221-5 onto various sizes of RG/U cable.

For connector assembly and cable stripping procedures, refer to instruction sheet 408-9088 for the plug connectors and 408-9089 for the jack connectors. Read these instructions thoroughly before using the hand tool assembly. This document supersedes Instruction Sheet 408-9282.

**NOTE**

*Dimensions on this sheet are in millimeters [with inches in brackets]. Figures are for reference only and are not drawn to scale.*

Reasons for reissue of this instruction sheet are provided in Section 9, REVISION SUMMARY.

**2. DESCRIPTION** (Figures 1 and 2)

The hand tool assembly features a tool frame with a stationary jaw and handle, a moving jaw, a moving handle, and an adjustable ratchet that ensures full connector crimping.

The tool frame holds a die assembly with two crimping chambers. The die assembly features a wire anvil, an insulation anvil, a wire indenter, and an insulation indenter. Die retaining pins and die retaining screws are used to position and secure the dies in the tool frame.

**3. INSTALLATION AND REMOVAL OF DIE ASSEMBLY** (Figure 2)

1. Open the tool handles and remove the two die retaining screws from the tool jaws.

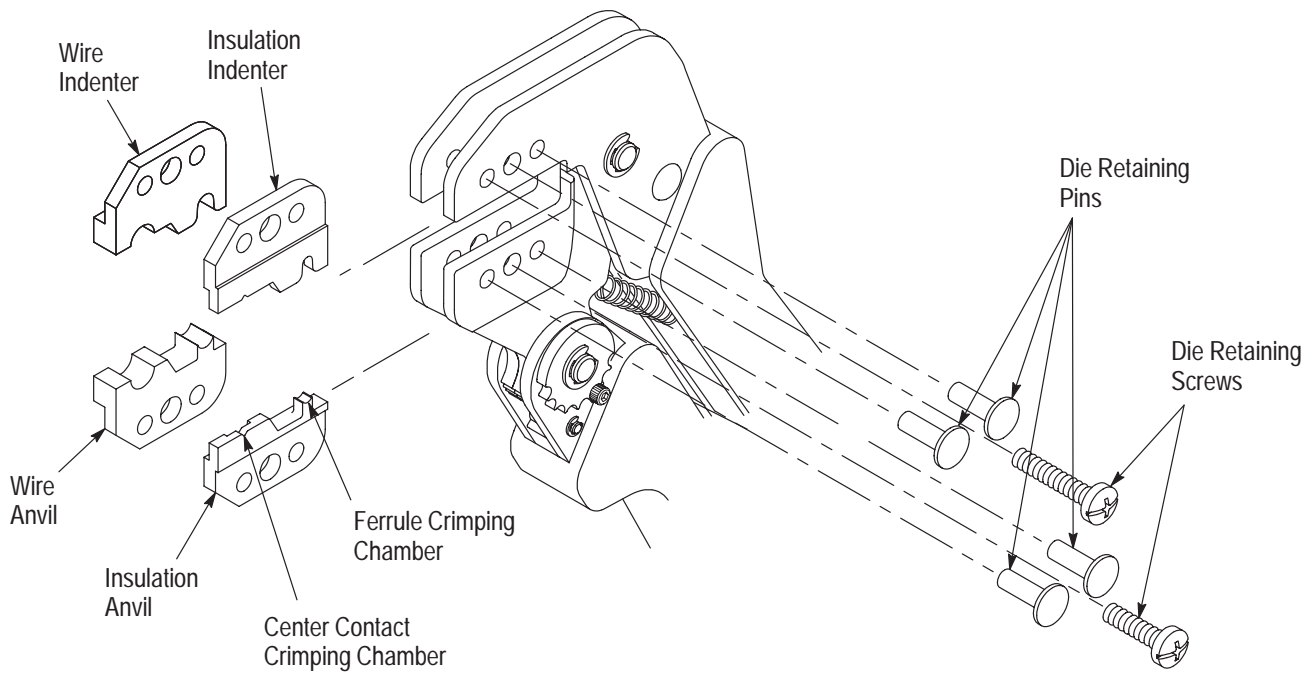

Figure 2

2. Place the wire anvil and insulation anvil so that their chamfered sides and their marked surfaces face outward, when mounted in the moving jaw of the tool frame.
3. Insert the two die retaining pins.
4. Insert the short die retaining screw through the jaw and through both anvil dies, and tighten the screw just enough to hold the dies in place. Do *not* tighten the screw completely at this time.
5. Place the wire indenter and insulation indenter so that their chamfered sides and their marked surfaces face outward, when mounted in the stationary jaw of the tool frame.
6. Insert the two die retaining pins.
7. Insert the long die retaining screw through the jaw and through both indenter dies, and tighten the screw just enough to hold the dies in place. Do *not* tighten the screw completely at this time.
8. Carefully close the tool handles, making sure that the anvils and indenters align properly. Continue closing the tool handles until the ratchet in the tool frame has engaged sufficiently to hold the anvils and indenters in place, then tighten both die retaining screws.
9. To remove, close the tool handles until the ratchet releases, remove the two die retaining screws and the four die retaining pins, and slide the anvils and indenters out of the tool jaws.

#### 4. CRIMPING PROCEDURE

##### NOTE

*This tool is provided with a crimp adjustment feature. Initially, the crimp height should be verified as specified in Figures 5 and 6. Refer to Section 5, INSPECTION, and Section 6, CRIMP HEIGHT ADJUSTMENT, to verify crimp before using the tool to crimp desired connectors and wire sizes.*

Slide the ferrule onto the cable and strip the cable according to the dimensions provided in the instructions packaged with the connector. Take care not to nick or cut wire strands. Proceed as follows:

##### 4.1. Center Contact (Figure 3)

1. Slide center contact onto stripped conductor. Insert center contact assembly into the partially closed center contact crimping chamber on the anvil die. Make sure the center contact flange is against the edge of the die as shown in Figure 3.
2. While holding the cable in place, crimp the center contact by closing the tool handles until the ratchet releases.
3. Allow the handles to open fully, and remove the crimped center contact from the die assembly.

##### 4.2. Ferrule (Figure 4)

1. Flare the cable braid and insert the crimped center contact into the connector body until the cable dielectric is against the dielectric inside the connector body. The flared braid will then fit over the support sleeve of the connector body.

**Center Contact Crimp**

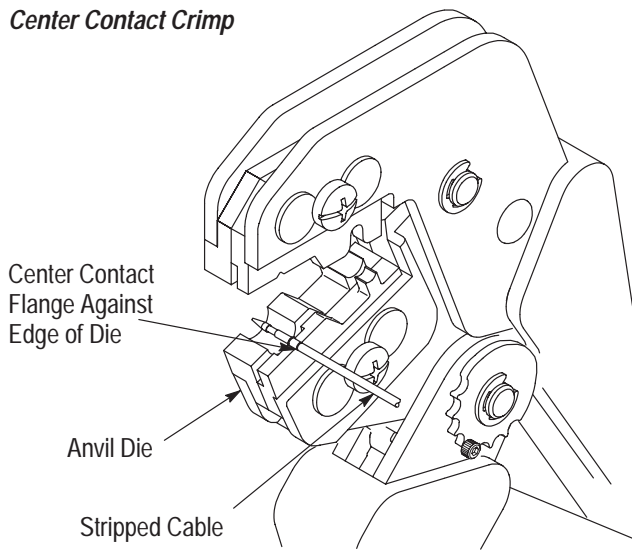

Figure 3

2. Slide the ferrule forward over the braid until the ferrule is against the connector body.
3. Place the ferrule in the crimping chamber on the anvil die so that the shoulder of the connector body is against the edge of the die. Refer to Figure 4.
4. Holding the assembly in place, close the tool handles until the ratchet releases.
5. Allow the handles to open fully, and remove the crimped assembly from the die assembly.

**CAUTION**

*Damaged contacts should not be used. If a damaged contact is evident, it should be cut from the wire and replaced with a new one. Contacts should not be reterminated.*

**5. INSPECTION**

**5.1. Visual Inspection**

The crimping dies should be inspected on a regular basis to ensure that they have not become worn or damaged. Inspect the crimping chambers for flattened, chipped, worn, or broken areas. If damage or abnormal wear is evident, the tool must be replaced. See Section 8, DIE REPLACEMENT.

**5.2. Periodic Inspection**

**A. Center Contact Crimp Height Inspection**

This inspection requires the use of a micrometer with a modified anvil as shown in Figure 5. Tyco Electronics recommends the modified micrometer (Crimp Height Comparator RS-1019-5LP), which can be purchased from:

Shearer Industrial Supply Co.  
717-767-7575

or VALCO  
610-691-3205

Proceed as follows to check the crimp height of the center contact:

1. Select the center contact for the connector.
2. Refer to Section 4, CRIMPING PROCEDURE, and crimp the center contact accordingly.
3. Using a crimp height comparator, measure the crimp height as shown in Figure 5. If the crimp height conforms to that shown, the die assembly is considered dimensionally correct. If not, return the dies to Tyco Electronics for evaluation and repair (refer to Section 8, DIE REPLACEMENT).

**Ferrule Crimp**

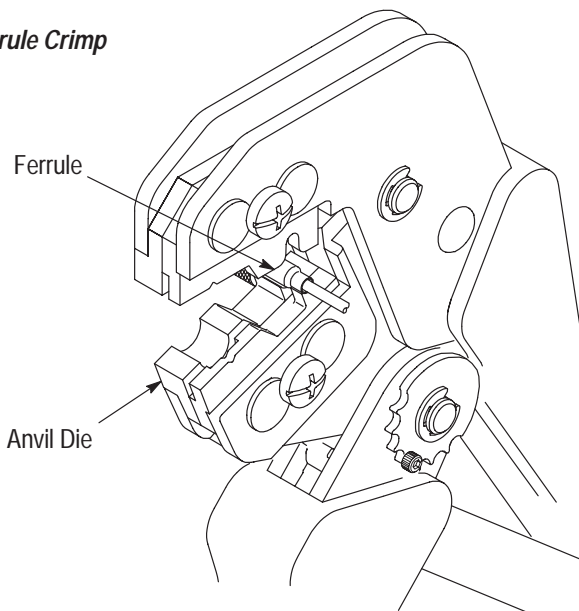

**Cross-Sectional View**

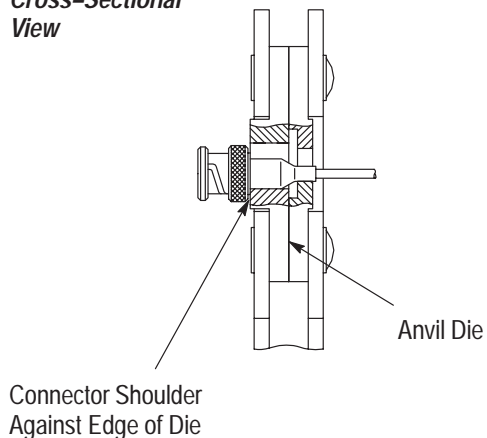

Figure 4

**Measuring Center Contact Crimp Height**

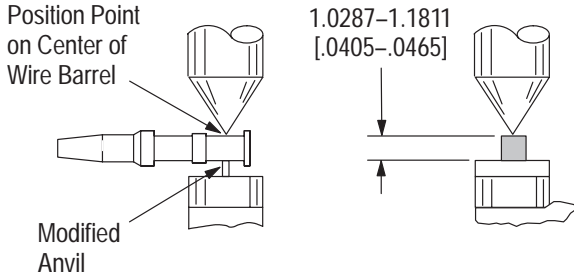

Figure 5

**B. Gaging the Ferrule Crimping Chamber**

This inspection requires the use of a plug gage conforming to the dimensions in Figure 6. Tyco Electronics does not manufacture or market these gages. To gage the ferrule crimping chamber, proceed as follows:

1. Close the jaws until the dies have bottomed, then HOLD the frame handles in this position. Do NOT force the dies beyond initial contact.
2. Align the GO element with the ferrule crimping chamber. Push the element straight into the crimping chamber without using force. The GO element must pass completely through the crimping chamber.
3. Align the NO-GO element and try to insert it straight into the same crimping chamber. The NO-GO element may start entry, but must not pass completely through.
4. Repeat Steps 2 and 3 for the insulation ferrule section of the crimping chamber.

**Suggested Plug Gage for Ferrule Crimping Chamber**

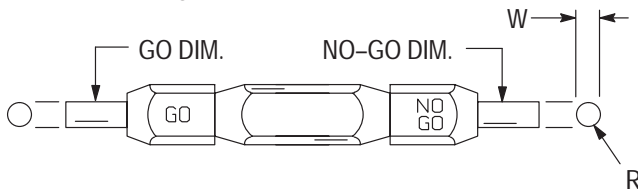

CRIMP SECTION	GAGE ELEMENT DIMENSIONS		RADIUS (Max) "R"	WIDTH (Max) "W"
	GO	NO-GO		
Ferrule	4.1910-4.1986 [.1650-.1653]	4.4424-4.4450 [.1749-.1750]	2.032 [.080]	4.064 [.160]
Insulation Ferrule	2.4130-2.4206 [.0950-.0953]	2.8676-2.8702 [.1129-.1130]	1.016 [.040]	2.286 [.090]

Figure 6

**NOTE**

Insert the gage element for the insulation ferrule section into the back of the crimping chamber. The GO element for this section will not pass completely through the crimping chamber.

If the crimping chamber conforms to the gage inspection, the dies are considered dimensionally correct, and should be lubricated with a THIN coat of any good SAE 20 motor oil. If not, the dies must be replaced before returning the die assembly to service (see Section 8, DIE REPLACEMENT).

For additional information regarding the use of a plug gage, refer to 408-7424.

**6. CRIMP HEIGHT ADJUSTMENT** (Figure 7)

The frame assembly ratchet mechanism features an adjustment wheel with numbered settings. If the crimp height is not acceptable, adjust the ratchet as follows:

1. Remove the lockscrew from the ratchet adjustment wheel.
2. With a screwdriver, adjust the ratchet wheel from the opposite side of the frame.
3. Observe the ratchet adjustment wheel. If a tighter crimp is required, rotate the adjustment wheel COUNTERCLOCKWISE to a higher-numbered setting. If a looser crimp is required, rotate the adjustment wheel CLOCKWISE to a lower-numbered setting.
4. Replace the lockscrew.

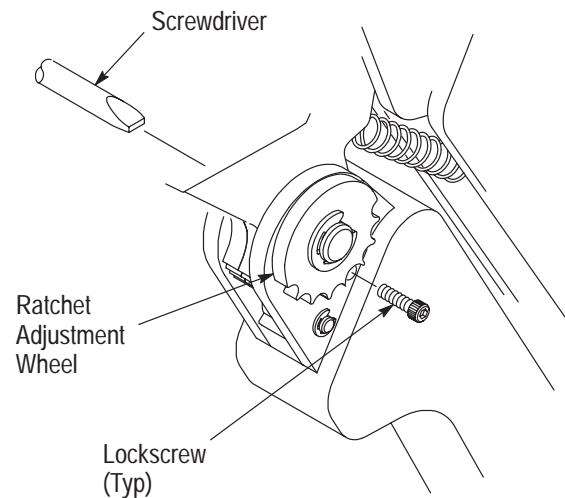

Figure 7

5. Make a sample crimp and measure the crimp height. If the crimp height is acceptable, secure the lockscrew. If the dimension is unacceptable, remove lockscrew and continue to adjust the ratchet, and again measure a sample crimp.

**7. MAINTENANCE**

Ensure that the tool and dies are clean by wiping them with a clean, soft cloth. Remove any debris with a clean, soft brush. Do not use objects that could damage the tool. When not in use, keep handles closed to prevent objects from becoming lodged in the crimping dies, and store in a clean, dry area.

CUSTOMER SERVICE (38-35)  
TYCO ELECTRONICS CORPORATION  
P.O. BOX 3608  
HARRISBURG, PA 17105-3608

For customer repair service, contact a Tyco Electronics Representative at 1-800-526-5136.

**8. DIE REPLACEMENT**

Customer-replaceable parts are shown in Figure 8. Spare parts or the die assembly should be stocked and controlled to prevent lost time when die replacement is necessary. Order replaceable parts through your Tyco Electronics Representative, or call 1-800-526-5142, or send a facsimile of your purchase order to 1-717-986-7605, or write to:

**9. REVISION SUMMARY**

Per EC 0990-0395-04:

- Updated document to corporate requirements
- Added new text to Section 1, INTRODUCTION
- Added new crimp information and note to artwork in Figure 8
- Added new lockscrew to Figures 1, 2, 3, 4, and 7

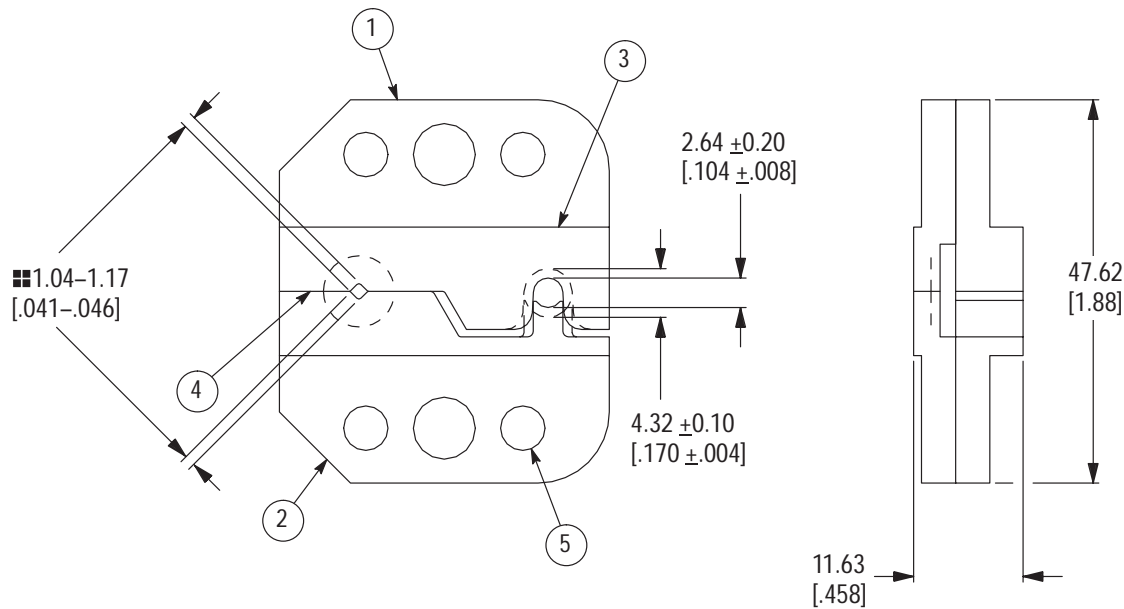

■ One side can go 0.064 [.0025] out of tolerance as long as the average measurements of both sides are within dimension specified.

Weight: 227 g [8 oz]

**CUSTOMER-REPLACEABLE PARTS FOR DIE ASSEMBLY 318451-2**

ITEM	PART NUMBER	DESCRIPTION	QTY PER ASSEMBLY
1	318432-1	INDENTER, Wire	1
2	318430-1	ANVIL, Wire	1
3	318431-2	INDENTER, Insulation	1
4	318429-2	ANVIL, Insulation	1
5	679231-1	PIN, Die Retaining	4

Figure 8