

PROPER USE GUIDELINES

Cumulative Trauma Disorders can result from the prolonged use of manually powered hand tools. AMP hand tools are intended for occasional use and low volume applications. AMP offers a wide selection of powered application equipment for extended-use, production operations.

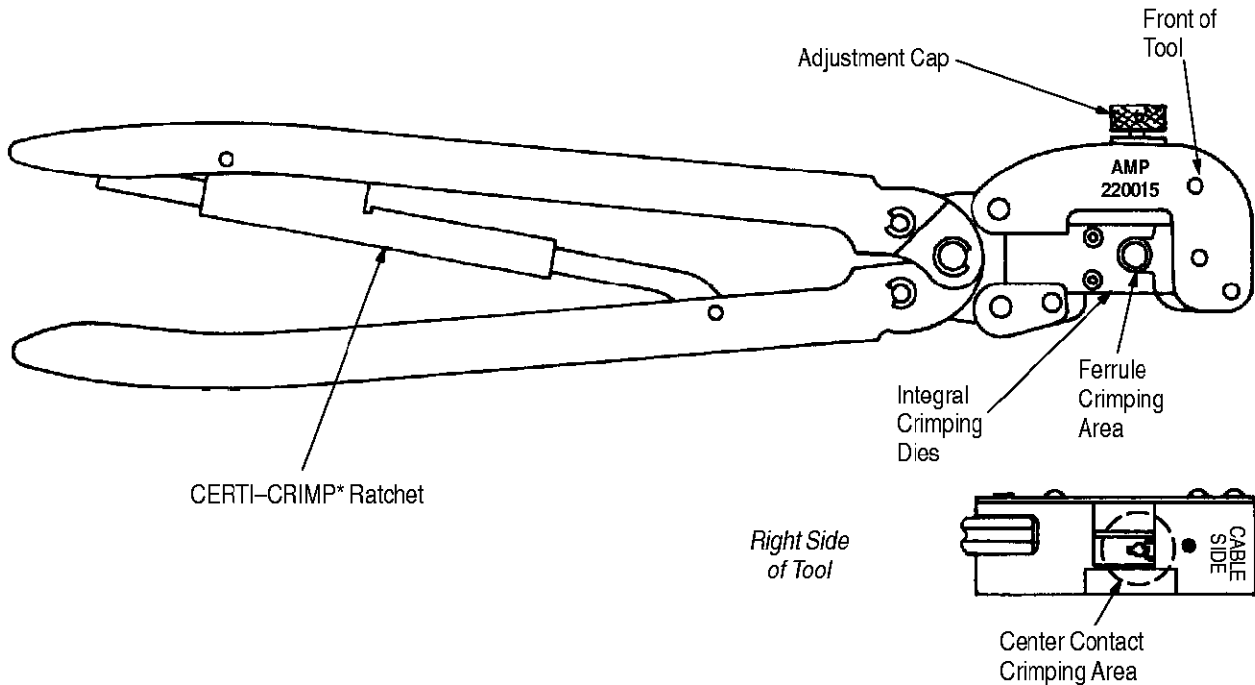

Figure 1

1. INTRODUCTION

This instruction sheet covers application and maintenance procedures for AMP* Heavy Head Hand Crimping Tools 220015-[]. Refer to Figure 1. The hand tools are used to crimp a variety of AMP coaxial connectors with flexible cable. For applicable connector part numbers and corresponding cable sizes, refer to AMP Catalog 82074. Information pertaining to the connectors (cable stripping dimensions and assembly of component parts) is included in instructions packaged with the connectors. Read all instructions thoroughly before proceeding.

NOTE *Dimensions on this sheet are in metric units [followed by U.S. customary units in brackets]. Figures and illustrations are for identification only and are not drawn to scale.*

Reasons for reissue are provided in Section 6, REVISION SUMMARY.

2. DESCRIPTION

Each tool features integral dies that have two crimping areas (one to crimp the center contact, and one to crimp the ferrule), an adjustment cap that

rotates the locator-stop (as required), and a CERTI-CRIMP ratchet which ensures full crimping. Once engaged, the ratchet will not release until the tool handles have been FULLY closed.

The FRONT of the tool is marked with the AMP part number. The center contact enters the crimping area from the RIGHT side of the tool. The contact/cable assembly is inserted through the BACK of the tool for ferrule crimping.

3. ASSEMBLY AND CRIMPING PROCEDURES

Select the appropriate cable and connector for the tool. Slip ferrule over cable; then strip cable to the proper length, according to instructions packaged with the connector (plug or jack).

3.1. Crimping the Center Contact

Refer to Figure 2 and proceed as follows:

1. Determine contact type (long or short) from the dimensions provided in Figure 2. Rotate locator/stop by turning adjustment cap to OPEN position for *long-type* contacts, or CLOSED position for *short-type* contacts.

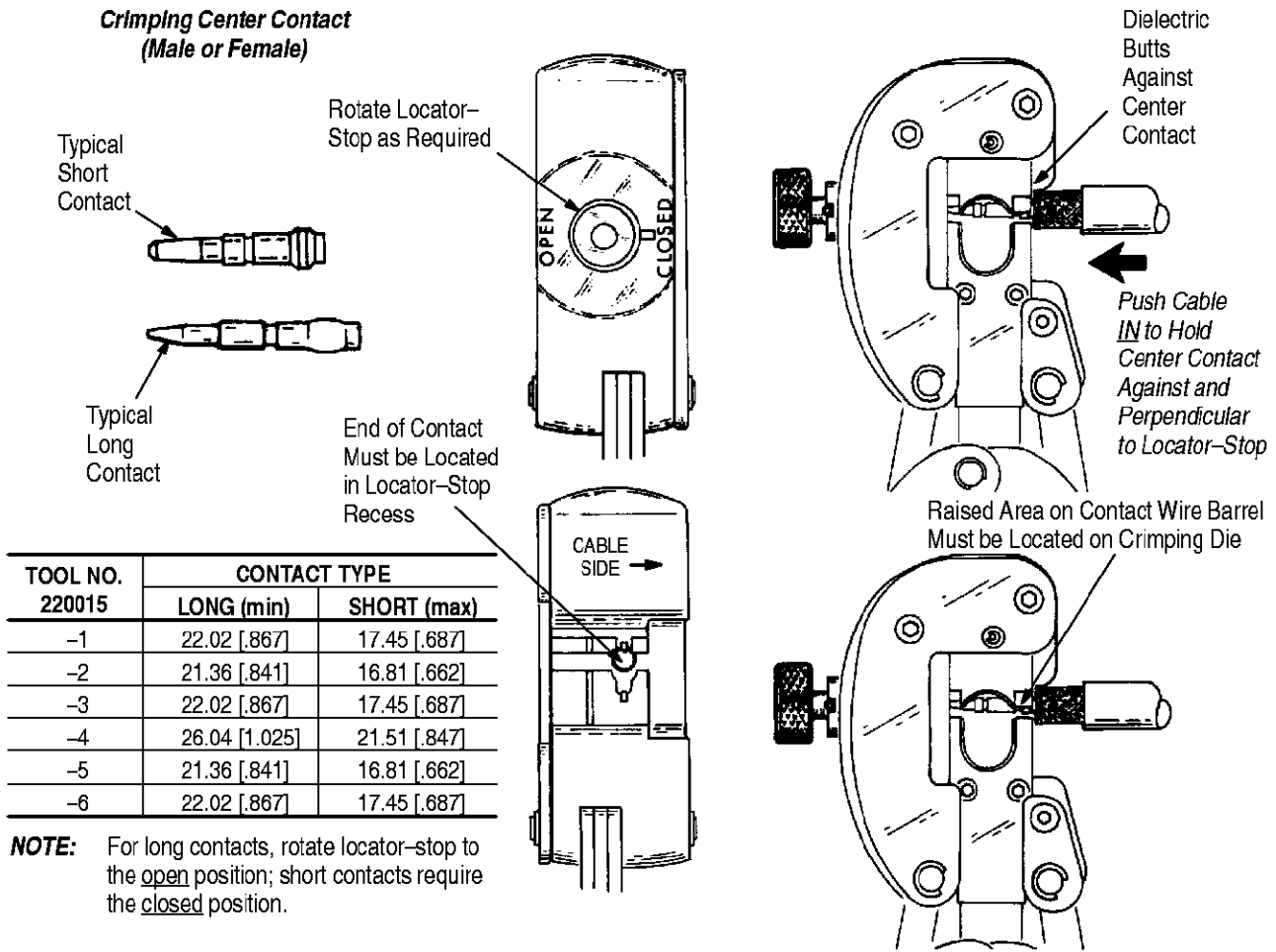

Figure 2

2. Insert conductor into contact wire barrel until contact butts against cable dielectric, and place contact in tool head as shown in Figure 2.
3. Push cable IN to hold center contact against and perpendicular to locator/stop. **MAKE SURE** that the **raised area** on the contact wire barrel is located **ON** the crimping die for proper termination.
4. Close tool handles **FULLY** until ratchet releases to complete crimp. Note that once the ratchet is engaged, handles cannot be opened until they have been fully closed.

2. Close handles until CERTI-CRIMP ratchet releases to complete crimp.

3.2. Crimping the Ferrule

Assemble the connector body over the crimped contact as described in connector instructions and proceed as follows:

1. Place connector assembly in tool as shown in Figure 3. **MAKE SURE** that the ferrule assembled on the cable is on the upper crimping die, and that the shoulder on the connector rests against the die, as shown.

Crimping Ferrule

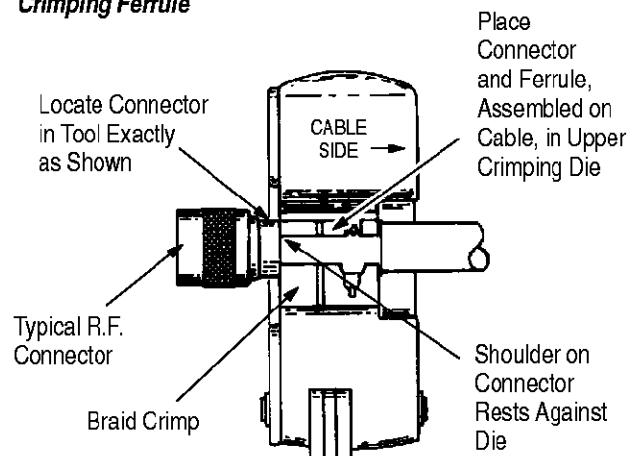

Figure 3

4. MAINTENANCE AND INSPECTION PROCEDURE

AMP recommends that a maintenance and inspection program be performed periodically to ensure dependable and uniform terminations. Though recommendations call for at least one inspection a month, frequency of inspection depends on:

1. The care, amount of use, and handling of the hand tool.
2. The presence of abnormal amounts of dust and dirt.
3. The degree of operator skill.
4. Your own established standards.

The hand tool is inspected before being shipped; however, AMP recommends that the tool be inspected immediately upon arrival to ensure that the tool has not been damaged during shipment.

4.1. Daily Maintenance

1. Hand tool should be immersed (handles partially closed) in a reliable commercial degreasing compound to remove accumulated dirt, grease, and foreign matter. When degreasing compound is not available, tool may be wiped clean with a soft, lint-free cloth. Do NOT use hard or abrasive objects that could damage the tool.
2. Make certain that the retaining pins are in place and that they are secured with retaining rings.
3. All pins, pivot points, and bearing surfaces should be protected with a THIN coat of any good SAE 20 motor oil. Do not oil excessively.
4. When the tool is not in use, keep handles closed to prevent objects from becoming lodged in the crimping jaws. Store the tool in a clean, dry area.

4.2. Periodic Inspection

A. Lubrication

Lubricate all pins, pivot points, and bearing surfaces with SAE 20 motor oil as follows:

- Tool used in daily production – lubricate daily
- Tool used daily (occasional) – lubricate weekly
- Tool used weekly – lubricate monthly

Wipe excess oil from tool, particularly from crimping area. Oil transferred from the crimping area onto certain terminations may affect the electrical characteristics of an application.

B. Visual Inspection

1. Close tool handles until ratchet releases and then allow them to open freely. If they do not open quickly and fully, the spring is defective and must

be replaced. See Section 6, REPLACEMENT AND REPAIR.

2. Inspect head assembly for worn, cracked, or broken jaws. If damage is evident, return the tool to AMP for evaluation and repair. See Section 6, REPLACEMENT AND REPAIR.

C. Gaging the Crimping Chambers

This inspection requires the use of a plug gage conforming to the dimensions provided in Figures 4 and 5. AMP does not manufacture or market these gages. To gage the crimping chamber, proceed as follows:

Inspecting Center Contact Dies

Plug gaging of the center contact crimping dies requires the use of two separate gages, which can be used in all 220015-[] tools. One gage is used inside the radius of the die closure; the other is used between the indent forming sections. Refer to Figure 4 and proceed as follows:

1. Close the tool handles until crimping dies are bottomed. Do NOT apply additional pressure, or ratchet will release.
2. With dies bottomed, check the indent-forming closure by using the box-type plug gage shown in Figure 4, Detail A. Align the GO element with the contact crimping chamber and insert the element without using force. The GO element must pass completely through the die closure.
3. Now align the NO-GO element and try to insert it straight into the same crimping chamber. The NO-GO element may start entry but must NOT pass completely through as shown in Figure 4.
4. Continue to hold the dies bottomed and insert the second (grooved) gage to inspect the radius of the dies, as shown in Figure 4, Detail B. Use the same method described in Steps 2 and 3.
5. If the die closure meets both plug gage conditions, the dies may be considered dimensionally correct.

Inspecting Braid and Braid Gap Crimping Dies

Figure 5 provides proper plug gage dimensions — according to tool dash number — for both the braid and the braid gap crimping areas. Figure 5 shows the location of both crimping areas for inspection. Proceed as follows:

1. Remove all traces of oil and dirt from tool crimping areas and gages.
2. Close tool handles until dies are bottomed, but not under pressure.

Inspection of Center Contact Crimping Dies with Plug Gages

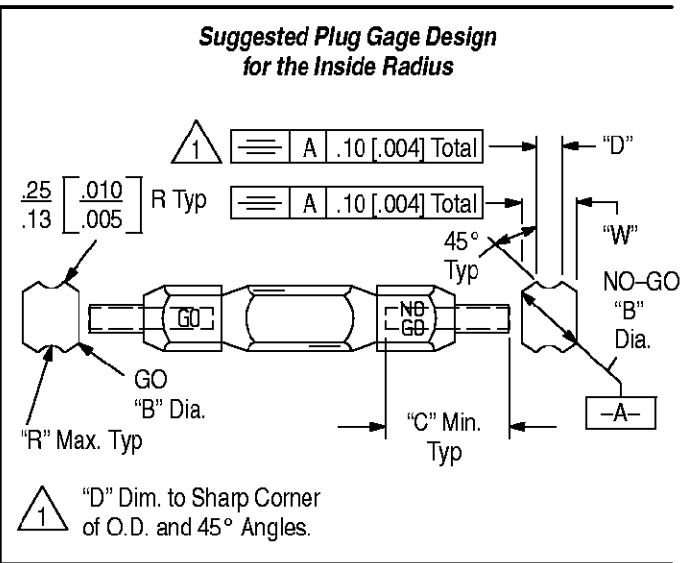
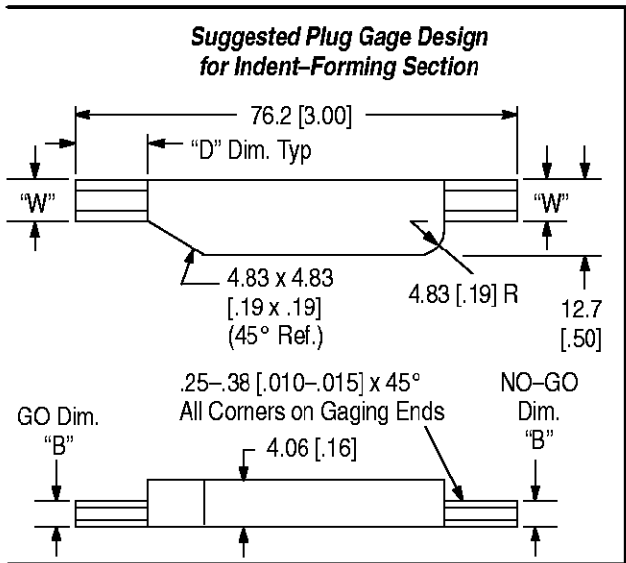
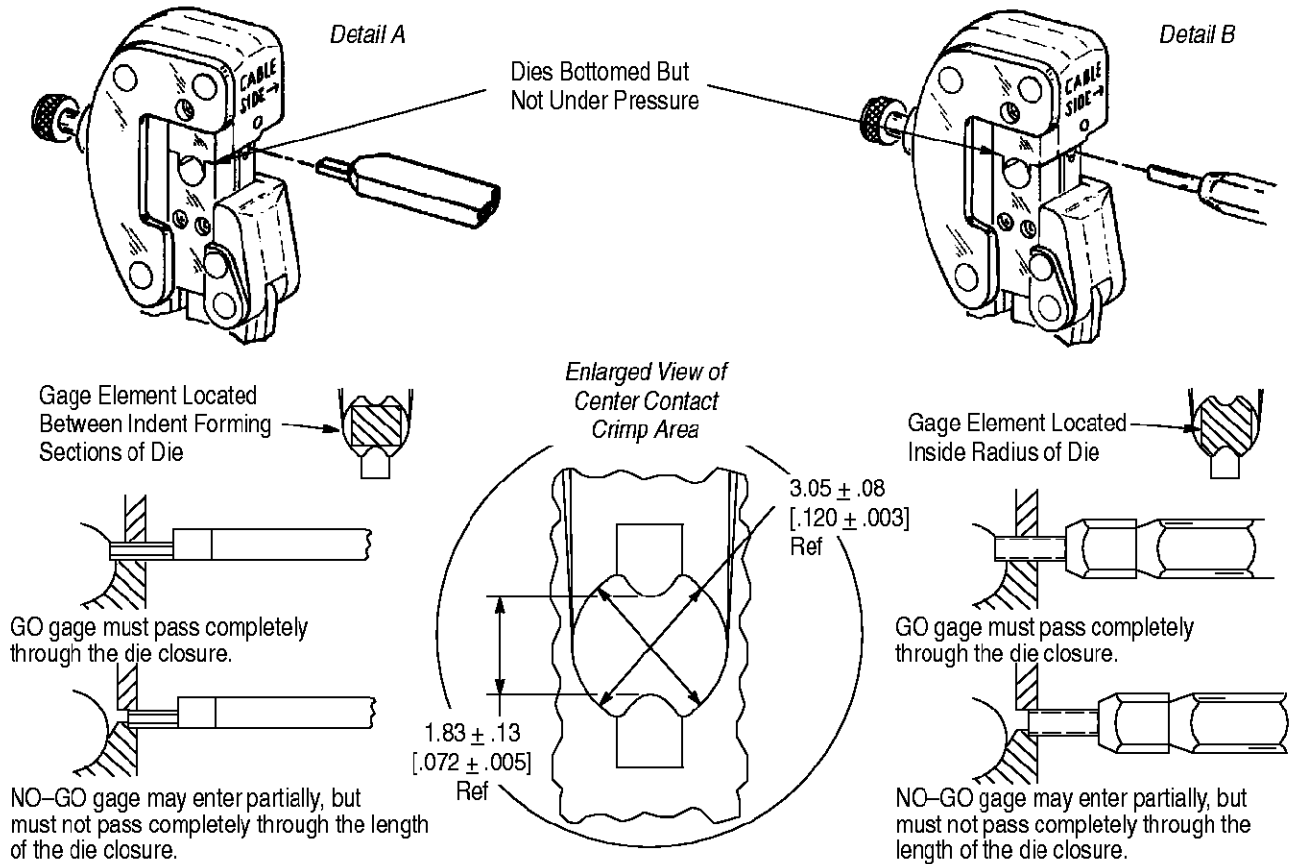

GAGE ELEMENT DIMENSIONS			
DIM. "B"		"W"	DIM. "D" TYP
GO	NO-GO		
1.702-1.709 [.0670-.0673]	1.953-1.956 [.0769-.0770]	2.29-2.41 [.090-.095]	9.65 [.380]

GAGE ELEMENT DIMENSIONS					
DIM. "B" (Dia)		DIM. "W"	DIM. "D"	DIM. "C"	RADIUS "R" (Max)
GO	NO-GO				
2.972-2.979 [.1170-.1173]	3.122-3.124 [.1229-.1230]	2.62 [.103]	1.57-1.73 [.062-.068]	25.4 [1.00]	.64 [.025]

Figure 4

Inspection of Braid and Braid Gap Crimping Dies with Plug Gages

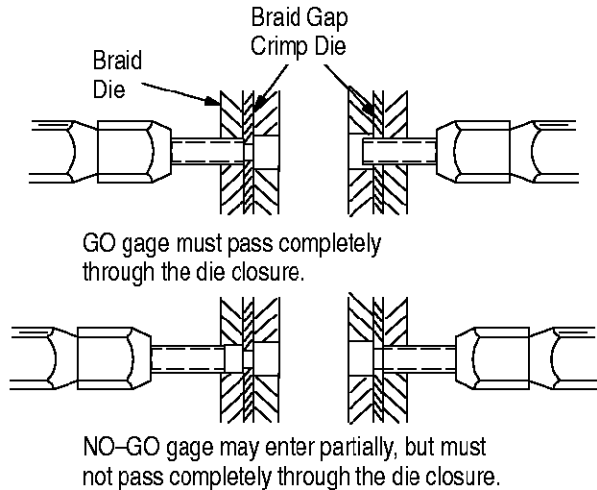
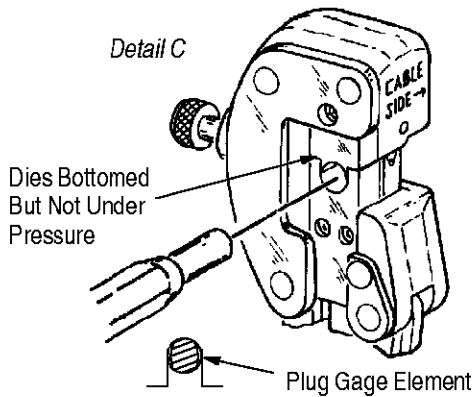

NOTE: Plug gage element must be held vertical in crimp die closure for proper measurement.

Suggested Plug Gage Design

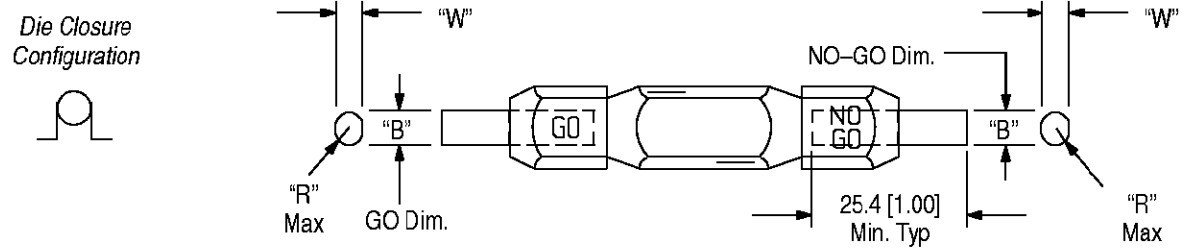

BRAID GAP DIES

TOOL NUMBER	GAGE ELEMENT DIMENSIONS			
	DIMENSION B		"W" MAX	RADIUS "R" (Max)
	GO	NO-GO		
220015-1 and -4	9.550-9.558 [.3760-.3763]	9.751-9.754 [.3839-.3840]	9.45 [.372]	4.72 [.186]
220015-2 and -6	7.264-7.272 [.2860-.2863]	7.465-7.468 [.2939-.2940]	7.16 [.282]	3.58 [.141]
220015-3	8.153-8.161 [.3210-.3213]	8.354-8.357 [.3289-.3290]	8.08 [.318]	4.04 [.159]
220015-5	6.706-6.713 [.2640-.2643]	6.906-6.909 [.2719-.2720]	6.60 [.260]	3.30 [.130]

BRAID DIES

TOOL NUMBER	GAGE ELEMENT DIMENSIONS			
	DIMENSION B		"W" MAX	RADIUS "R" (Max)
	GO	NO-GO		
220015-1 and -4	10.389-10.396 [.4090-.4093]	10.589-10.592 [.4169-.4170]	10.29 [.405]	5.16 [.203]
220015-2 and -6	8.052-8.059 [.3170-.3173]	8.252-8.255 [.3249-.3250]	7.98 [.314]	3.99 [.157]
220015-3	8.992-8.999 [.3540-.3543]	9.192-9.195 [.3619-.3620]	8.92 [.351]	4.47 [.176]
220015-5	7.264-7.272 [.2860-.2863]	7.465-7.468 [.2939-.2940]	7.21 [.284]	3.61 [.142]

Figure 5

3. Using the proper plug gage, check the braid and the braid gap closure with dies bottomed. Hold gage in straight alignment with the dies and carefully try to insert, without forcing, first the GO element, and then the NO-GO element. The GO element must pass completely through the crimp die closure. *The gage for the braid die will butt against the braid gap crimp die.*

4. The NO-GO gage may enter partially, but must NOT pass completely through the crimp die closure.

If crimping chambers conform to gage inspection, the tool is considered dimensionally correct, and should be lubricated with a THIN coat of any good SAE 20 motor oil. If not, refer to Section 5, REPLACEMENT AND REPAIR for customer repair service.

D. CERTI-CRIMP Ratchet Inspection

The CERTI-CRIMP ratchet feature on AMP hand tools should be checked to ensure that the ratchet does not release prematurely, allowing the jaws to open before they have fully bottomed. Obtain a 0.025

[.001] shim that is suitable for checking the clearance between the bottoming surfaces of the crimping jaws. Proceed as follows:

1. Position the connector and wire between the crimping jaws, as described in Section 3, ASSEMBLY AND CRIMPING PROCEDURES.
2. Hold the wire in place and squeeze the handles until the CERTI-CRIMP ratchet releases. Hold the handles in this position, maintaining just enough tension to keep the jaws closed.
3. Check the clearance between the bottoming surfaces of the crimping jaws. If the clearance is 0.025 [.001] or less, the ratchet is satisfactory. If clearance exceeds 0.025 [.001], the ratchet is out of adjustment and must be repaired. See Section 5, REPLACEMENT AND REPAIR.

5. REPLACEMENT AND REPAIR

Replacement parts are listed in Figure 6. Parts other than those listed in Figure 6 should be replaced by

AMP to ensure quality and reliability of the tool. Order replacement parts through your AMP representative, or call 1-800-526-5142, or send a facsimile of your purchase order to 1-717-986-7605, or write to:

CUSTOMER SERVICE (38-35)
 AMP INCORPORATED
 P.O. BOX 3608
 HARRISBURG, PA 17105-3608

For tool repair service, please contact an AMP representative at 1-800-526-5136.

6. REVISION SUMMARY

Since the previous release of this sheet, the following changes were made:

Per EC 0990-0927-99

- Updated document to corporate requirements
- Removed Figure 2 list of connectors and replaced with reference to Catalog 82074
- Changed tool repair service information in Section 5, REPLACEMENT AND REPAIR

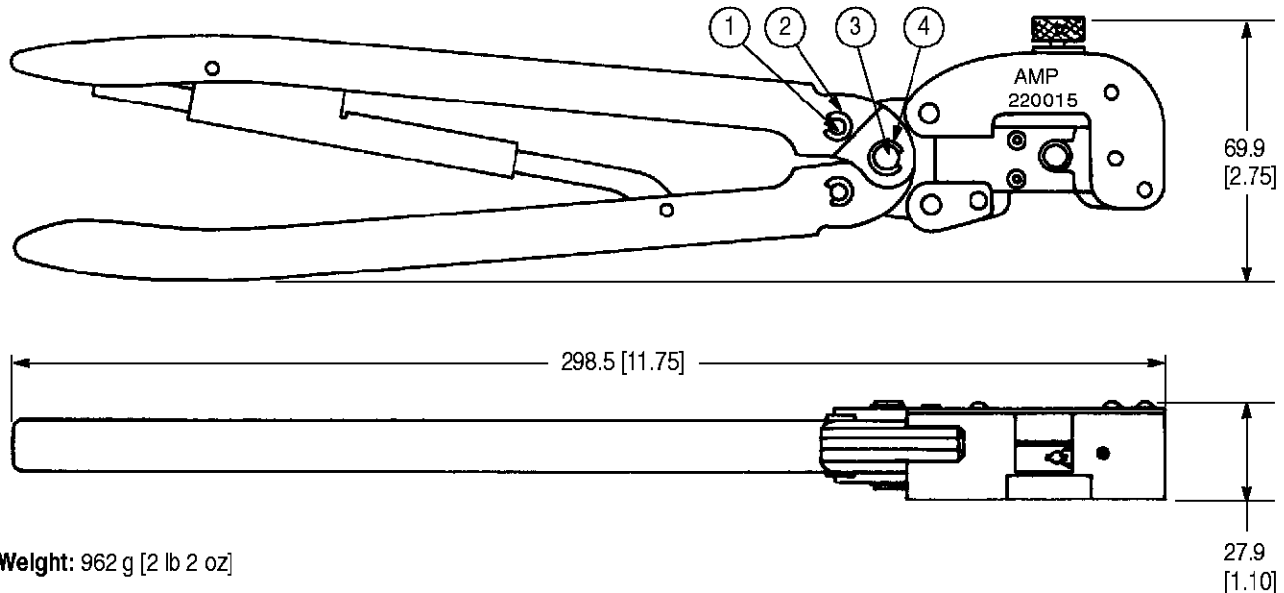

Weight: 962 g [2 lb 2 oz]

REPLACEMENT PARTS

ITEM	PART NUMBER	DESCRIPTION	QTY PER ASSY
1	300388	PIN, Retaining	2
2	21045-3	RING, Retaining	4
3	300389	PIN, Retaining	1
4	21045-6	RING, Retaining	2

Figure 6