

SERPAC 223-1 (exploded isometric)

Electronic Enclosures

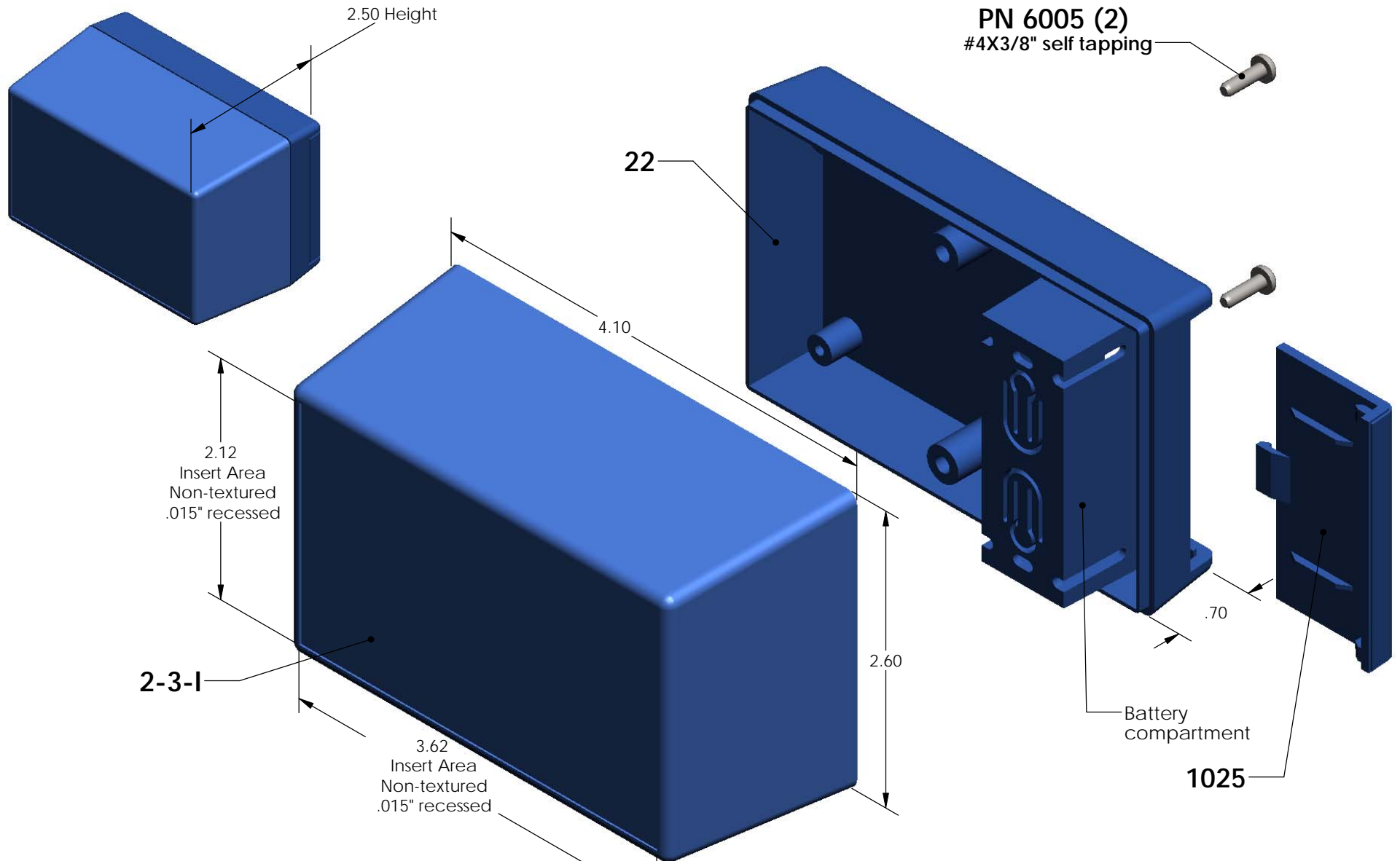

PART NO.	DESCRIPTION (Included)	ACCESSORIES (Optional)	
2-3-1	TOP	PART NO.	DESCRIPTION
22	BOTTOM	319	Prototype grid board (Bottom)
1025	Battery Cover	419	Prototype clad board (Bottom)
6005	#4X3/8" Self tapping (2)		

Notes: (Enclosure weight 0.21 lb / 98 gm)
 1) Enclosure meets or exceeds IP40 and NEMA 1
 2) Top Circuit Board drawings can be download at:
http://www.serpac.com/Products/Accessories/CircuitBoard/drawings/CB_12X.pdf
 3) All components are RoHS Compliant.

ALL DIMENSIONS ARE ± .010" 6/29/09 (1 of 2)
 619 Commercial Ave. Covina, CA 91723
 Ph. (626) 331-0517 Fx. (626) 331-8584 serpac.com

SERPAC 223-1 (user print)

Electronic Enclosures

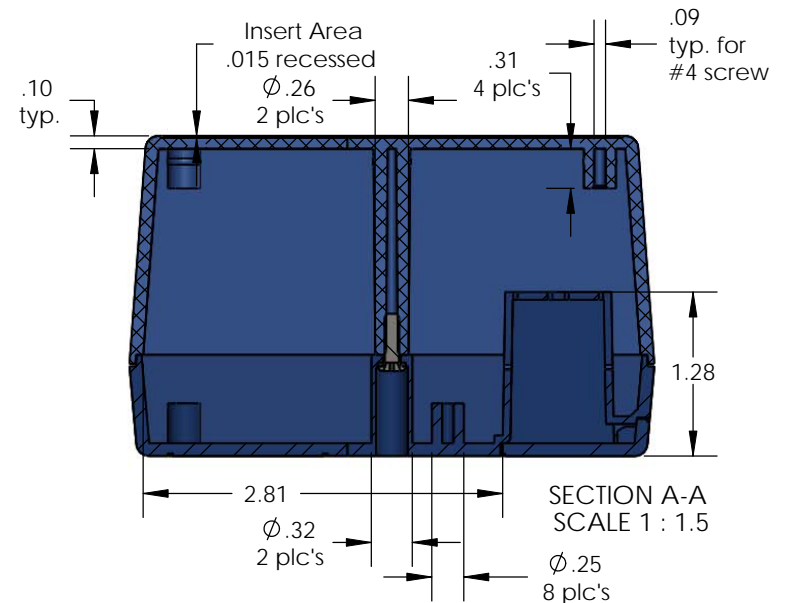
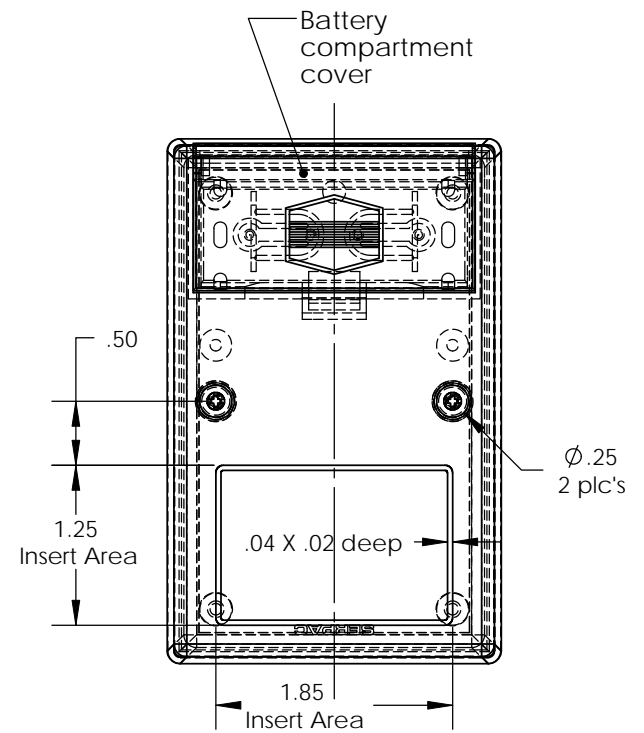
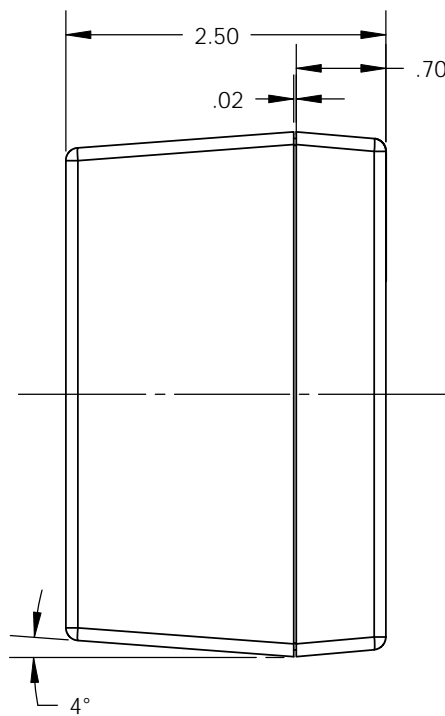
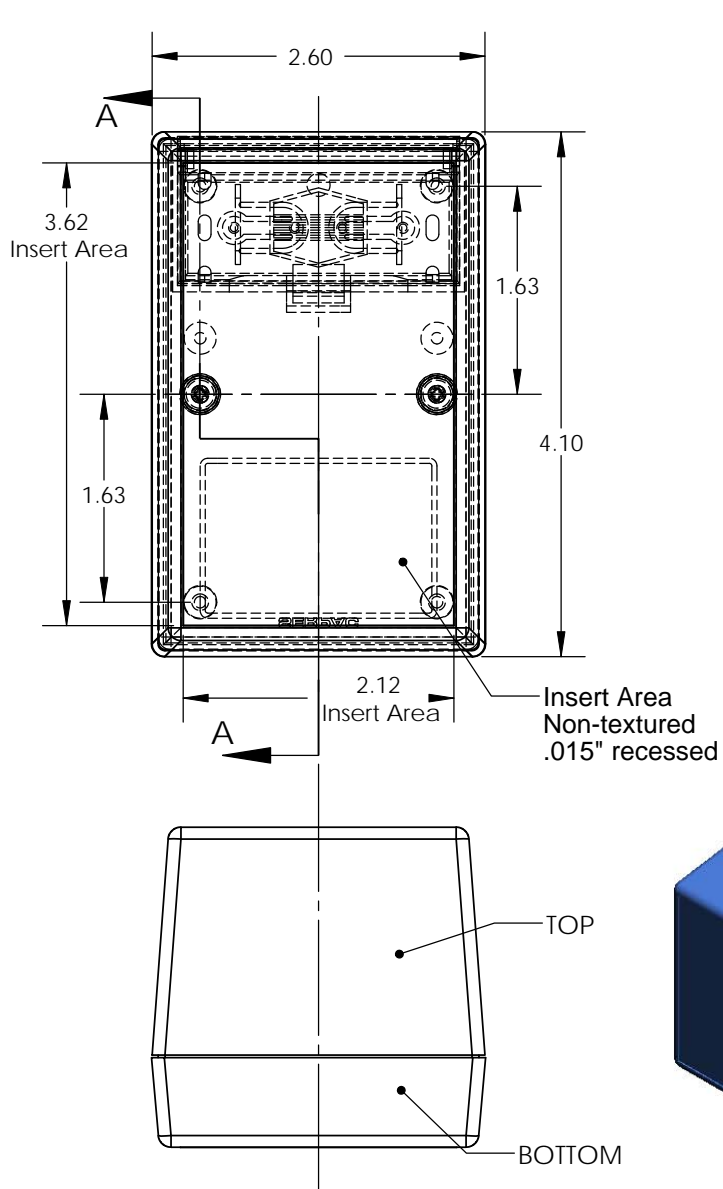

PART NO.	DESCRIPTION (Included)	ACCESSORIES (Optional)
2-3-1	TOP	PART NO. DESCRIPTION
22	BOTTOM	319 Prototype grid board (Bottom)
1025	Battery Cover	419 Prototype clad board (Bottom)
6005	#4X3/8" self tapping (2)	

- Notes: (Enclosure weight 0.21 lb / 98 gm)
 1) Enclosure meets or exceeds IP40 and NEMA 1
 2) Top Circuit Board drawings can be download at:
http://www.serpac.com/Products/Accessories/CircuitBoard/drawings/CB_12X.pdf
 3) All components are RoHS Compliant.

ALL DIMENSIONS ARE ± .010" 6/29/09 (2 of 2)
 619 Commercial Ave. Covina, CA 91723
 Ph. (626) 331-0517 Fx. (626) 331-8584 www.serpac.com