

REL-SG 24/B110

Order No.: 2960067

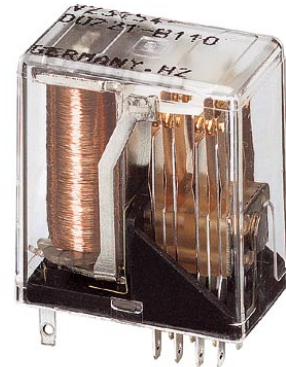

<http://eshop.phoenixcontact.de/phoenix/treeViewClick.do?UID=2960067>

KAMMRELAIS®, contact B 110, size 2, low-level contact, 4 PDTs,
input voltage 24 V DC

Commercial data

EAN	4017918086473
Pack	10 Pcs.
Customs tariff	85364190
Weight/Piece	0.02777 KG
Catalog page information	Page 103 (IF-2002)

Product notes

WEEE/RoHS-compliant since:
09/18/2006



<http://www.download.phoenixcontact.com>
Please note that the data given here has been taken from the online catalog. For comprehensive information and data, please refer to the user documentation. The General Terms and Conditions of Use apply to Internet downloads.

Technical data

Coil side

Nominal input voltage U_N	24 V DC
Input voltage range in reference to U_N	0.8 ... 1.1
Typical response time	8 ms
Typical release time	3 ms
Coil resistance	890 Ω +/- 89

Contact side

Contact type	Single contact
Contact material	Silver (Ag), gold-flashed
Maximum switching voltage	125 V AC 150 V DC
Maximum inrush current	2 A
Limiting continuous current	2 A
Interrupting rating (ohmic load) max.	48 W (for 24 V DC) 40 W (for 48 V DC) 40 W (for 60 V DC) 45 W (for 110 V DC) 50 VA (for 125 V AC)

General data

Test voltage relay winding/relay contact	500 V AC (50 Hz, 1 min)
Test voltage PDT/PDT	500 V AC (50 Hz, 1 min)
Ambient temperature (operation)	-40 °C ... 70 °C
Ambient temperature (storage/transport)	-40 °C ... 70 °C
Service life mechanical	Approx. 10 ⁸ cycles

Certificates / Approvals

Approval logo



requested approbations

Certification	GOST
---------------	------

Drawings

Circuit diagram

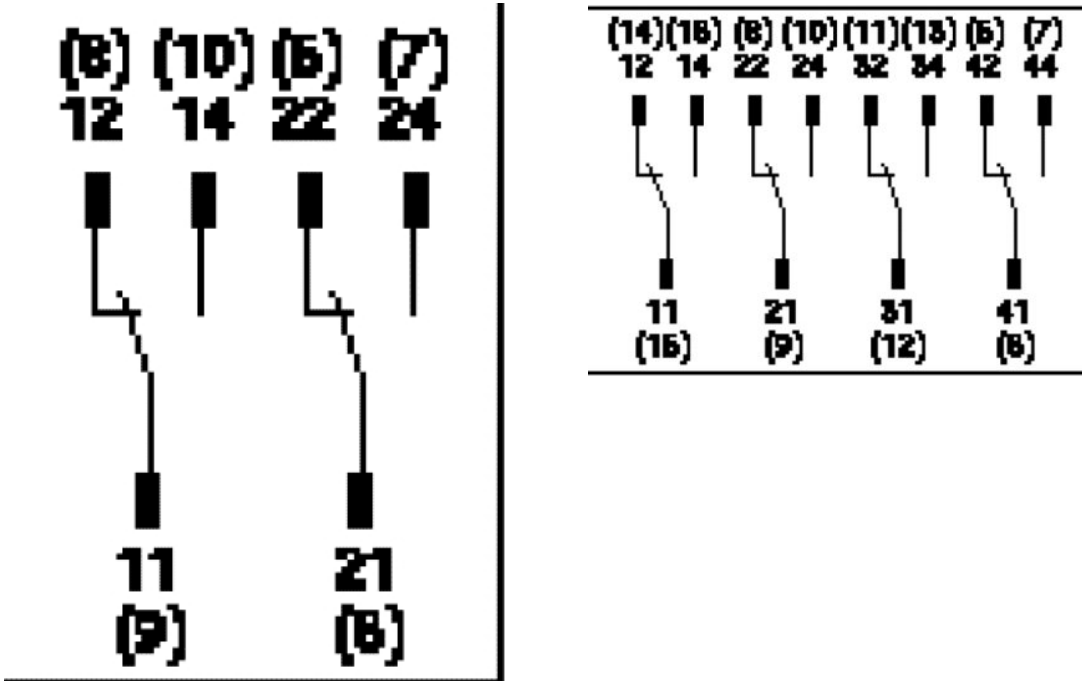

Address

PHOENIX CONTACT GmbH & Co. KG
Flachsmarktstr. 8
32825 Blomberg, Germany
Phone +49 5235 3 00
Fax +49 5235 3 41200
<http://www.phoenixcontact.de>



© 2008 Phoenix Contact
Technical modifications reserved;