

UEGM 25

Order No.: 2792015

Illustration shows version UEGM 22.5

<http://eshop.phoenixcontact.de/phoenix/treeViewClick.do?UID=2792015>

Electronic housing, for PCB insertion, fully equipped with 3 screw or 6
tab connections per side

Commercial data

EAN	4017918072520
Pack	10 Pcs.
Customs tariff	85369010
Weight/Piece	0.05804 KG
Catalog page information	Page 520 (CC-2007)

Product notes

WEEE/RoHS-compliant since:
01/01/2003



[http://
www.download.phoenixcontact.com](http://www.download.phoenixcontact.com)
Please note that the data given
here has been taken from the
online catalog. For comprehensive
information and data, please refer
to the user documentation. The
General Terms and Conditions of
Use apply to Internet downloads.

Certificates / Approvals

Approval logo



CUL

Nominal voltage U_N	300 V
Nominal current I_N	10 A
AWG/kcmil	30-12

UL

Nominal voltage U_N	300 V
Nominal current I_N	10 A
AWG/kcmil	30-12
Certification	CUL, GOST, UL

Accessories

Item	Designation	Description
Bridges		
2820916	DB 50- 90 BK	Wire bridge, 50-position, divisible, for bridging identical inputs and outputs, 0.5 mm ² , insulation: black
2820929	DB 50- 90 GY	Wire bridge, 50-position, divisible, for bridging identical inputs and outputs, 0.5 mm ² , insulation: gray

Cable/conductor

1406700	PT/FS 2,8	Plastic sheath, as touch protection, slide onto the conductor before for 2.8 slip-on sleeves
0604707	PT/FS 6,3	Plastic sheath, as touch protection, slide onto the conductor before for 6.3 slip-on sleeves

General

2792109	P 1-UEGM	PCB, for screw and slip-on connection, for custom fitting electronic components.
---------	----------	--

Marking

1050004	ZB 5 :UNBEDRUCKT	Zack strip, unprinted, 10-section, for individual labeling with M-PEN, ZB-T or CMS system, pack is sufficient for 100 terminal blocks, for a terminal width of 5.2 mm, color: White
---------	------------------	---

Plug/Adapter

2790389	UEG-MT-FS	Metal part for slip-on connection, to increase the number of positions.
---------	-----------	---

Drawings

Explosion drawing

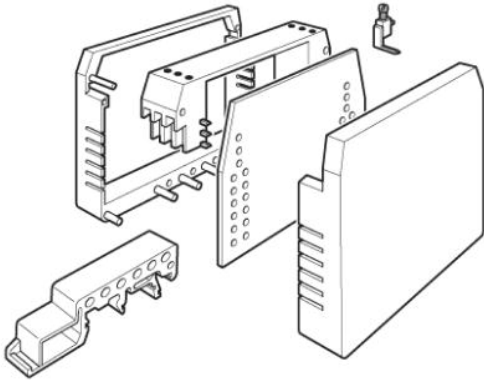

Dimensioned drawing

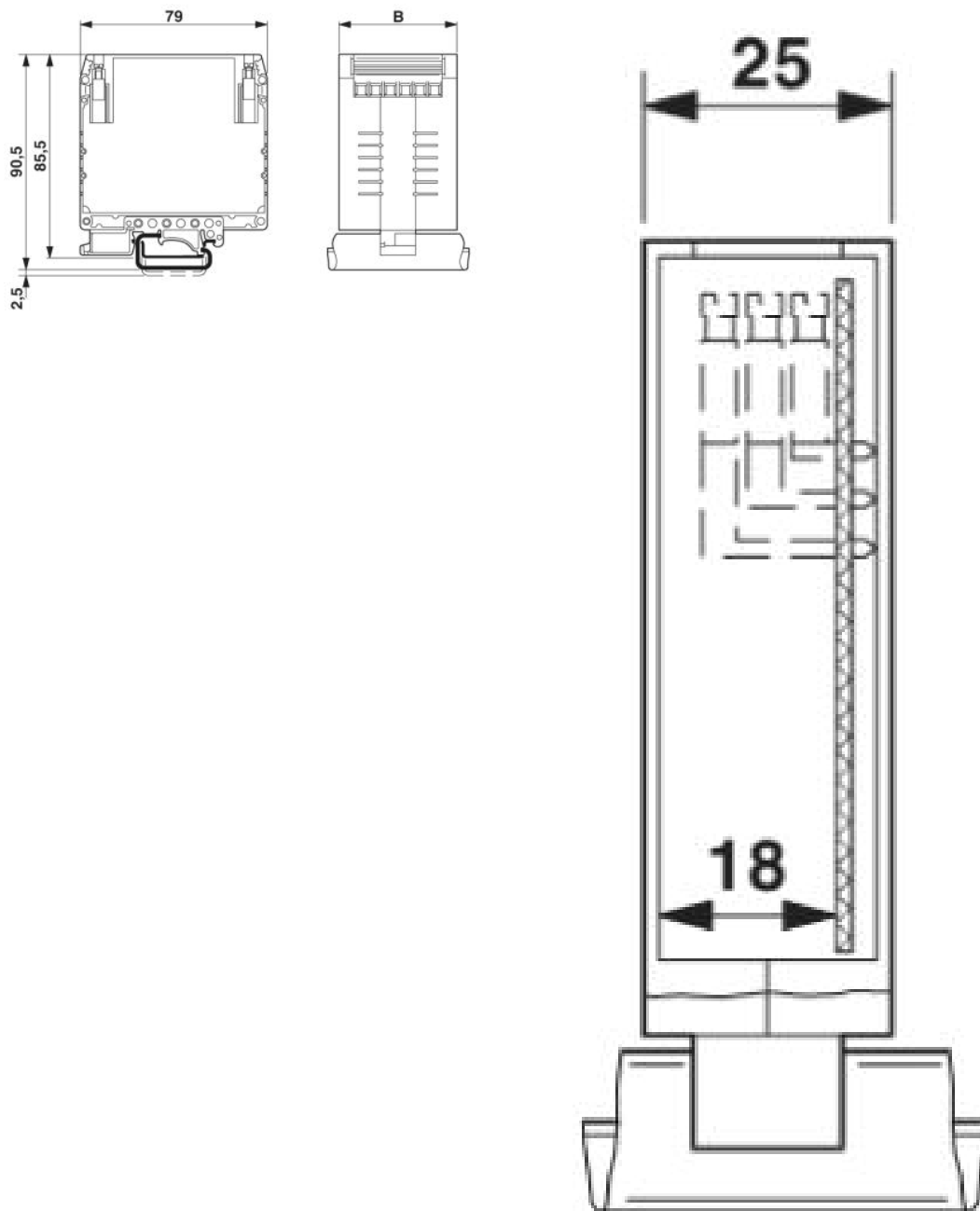

UEGM 25... und UEGM 27,5-SMD with 1 PCB,
6 positions or 12 positions (FS/FS)

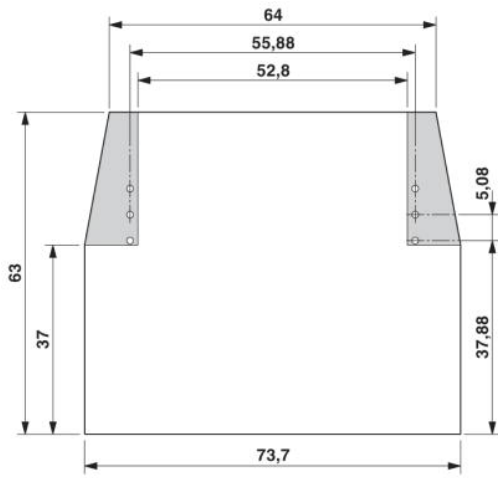

Schematic diagram

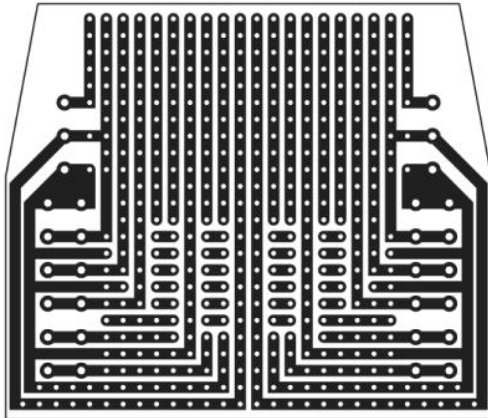

Address

PHOENIX CONTACT Inc., USA
586 Fulling Mill Road
Middletown, PA 17057, USA
Phone (800) 888-7388
Fax (717) 944-1625
<http://www.phoenixcon.com>



© 2008 Phoenix Contact
Technical modifications reserved;