

Enter keywords or part number

[What's New](#) | [Products](#) | [Solutions](#) | [Design](#) | [AppNotes](#) | [Support](#) | [Sales](#) | [About Us](#) | [Members](#)
[Maxim](#) > [Products](#) > [\[Analog Switches and Multiplexers\]](#)

## MAX4843, MAX4844, MAX4845, MAX4846

Overvoltage Protection Controllers with Low Standby Current

### Industry's Smallest Overvoltage Protection Controllers

[QuickView](#) | [Technical Documents](#) | [Ordering Info](#) | [More Information](#) | [User Comments \(0\)](#) | [All](#)

#### Status

Active: In Production.

#### Description

The MAX4843–MAX4846 overvoltage protection controllers protect low-voltage systems against high-voltage faults of up to 28V. When the input voltage exceeds the overvoltage threshold, these devices turn off a low-cost, external n-channel FET(s) to prevent damage to the protected components. An internal charge pump eliminates the need for external capacitors and drives the FET gate for a simple, robust solution.

[Request Full Data Sheet](#)

The overvoltage trip level is set to 7.4V (MAX4843), 6.35V (MAX4844), 5.8V (MAX4845), or 4.65V (MAX4846). When the input voltage drops below the undervoltage lockout (UVLO) threshold, the devices enter a low standby current mode (10 $\mu$ A). The MAX4843/MAX4844/MAX4845 have a UVLO threshold of 4.15V, and the MAX4846 has a UVLO threshold of 2.5V. In addition to the single FET configuration, the devices can be configured with back-to-back external FETs to prevent currents from being back-driven into the adapter.

An additional feature includes a  $\pm 15$ kV ESD-protected input when bypassed with a 1 $\mu$ F capacitor to ground. All devices are offered in small 6-pin  $\mu$ DFN (1.5mm x 1.0mm) and 6-pin ultra-thin LGA (MAX4845EYT+T only) (1.5mm x 1.0mm) packages and are specified for operation over the -40 $^{\circ}$ C to +85 $^{\circ}$ C temperature range.

#### Key Features

- Overvoltage Protection Up to 28V
- Preset 7.4V, 6.35V, 5.8V, or 4.65V Overvoltage Trip Level
- Low (10 $\mu$ A) Undervoltage Lockout Standby Current
- Drives Low-Cost nMOSFET
- Internal 50ms Startup Delay
- Internal Charge Pump
- Overvoltage Fault FLAG Indicator
- 6-Pin (1.5mm x 1.0mm)  $\mu$ DFN Package

#### Applications/Uses

- Cell Phones
- Digital Still Cameras
- MP3 Players
- PDAs and Palmtop Devices

#### Key Specifications: Overvoltage Protection Controllers

Part Number	Channels	$V_{IN}$ (V)		Over Voltage Trip Level (V)	Under Voltage Lockout (V)	$V_{GATE}$ (V)	Over Volt. Flag	$t_{GATE}$ (On) (ms)	$t_{GATE}$ (Off) ( $\mu$ s)	Features	Package/Pins	Price
		min	max									See Notes
<a href="#">MAX4843</a>				7.4	4.15						$\mu$ DFN/6	\$0.70 @1k
<a href="#">MAX4844</a>				6.35	4.15					Internal Charge Pump	$\mu$ DFN/6	\$0.70 @1k
<a href="#">MAX4845</a>	1	1.2	28	5.8	4.15	10	Open-Drain	10	6	Soft Start	$\mu$ DFN/6 UTLGA/6	\$0.70 @1k
<a href="#">MAX4846</a>				4.65	2.5						$\mu$ DFN/6	\$0.70 @1k

[See All Overvoltage Protection Controllers \(47\)](#)

#### Diagram

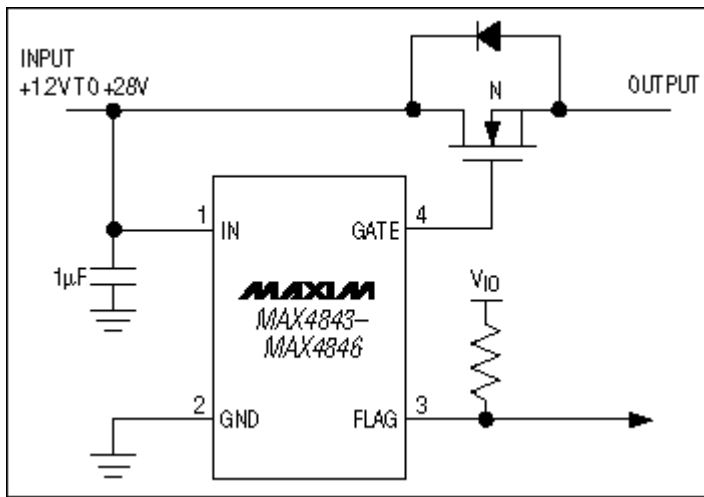

Typical Operating Circuit

#### Didn't Find What You Need?

- [Next Day Product Selection Assistance from Applications Engineers](#)
- [Parametric Search](#)
- [Applications Help](#)

#### QuickView

[Description](#)  
[Key Features](#)  
[Applications/Uses](#)  
[Key Specifications](#)  
[Diagram](#)

#### Technical Documents

[Data Sheet](#)  
[Application Notes](#)  
[Design Guides](#)  
[Engineering Journals](#)  
[Reliability Reports](#)  
[Software/Models](#)  
[Evaluation Kits](#)

#### Ordering Info

[Price and Availability](#)  
[Samples](#)  
[Buy Online](#)  
[Package Information](#)  
[Lead-Free Information](#)

#### More Information

[Related Products](#)  
[Notes and Comments](#)  
[Evaluation Kits](#)

Document Ref.: 19-3649; Rev 3; 2008-04-09  
 This page last modified: 2008-04-09

[Contact Us](#) • [Rate This Page](#) • [Mail This Page](#) • [Privacy Policy](#) • [Legal Notices](#)

Copyright © 2009 by Maxim Integrated Products