

FC-23629-C36

SHT 1.1

NOTES:

- INCREASED PRESSURE AT THE SOUND INLET CAUSES A POSITIVE GOING VOLTAGE TO APPEAR AT THE OUTPUT TERMINAL, RELATIVE TO THE NEGATIVE TERMINAL.

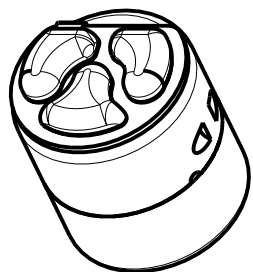
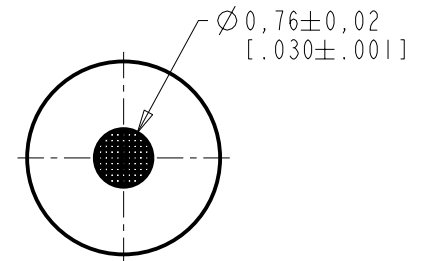
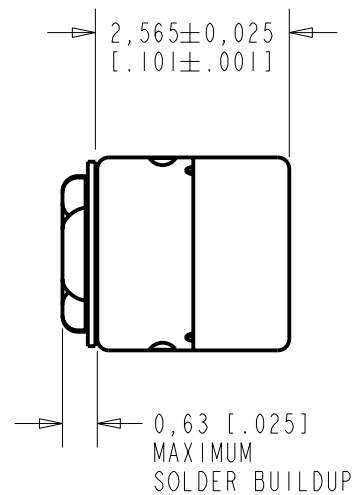
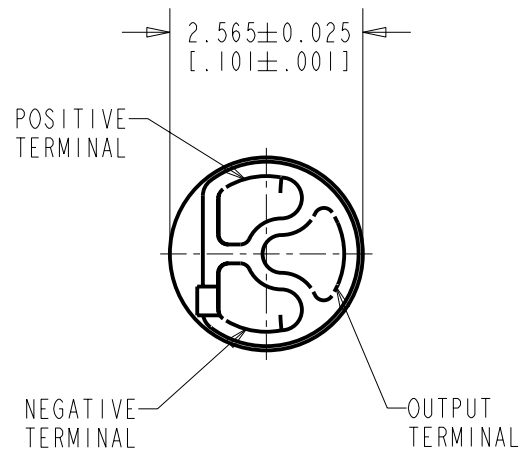

DIMENSIONS IN MILLIMETERS [INCHES]

KNOWLES ELECTRONICS
ITASCA, ILLINOIS U.S.A.

Revision	C.O. #	Implementation Date	RELEASE LEVEL	REVISION
B	MI0100967	1-20-06	Released	B
A	MI0100781	9-22-05		
SCALE: 10:1			DR. BY: DMS	DATE: 9-15-05
DO NOT SCALE DRAWING			CK. BY: GJP	DATE: 9-26-05
TITLE: MICROPHONE		FC-23629-C36	APP. BY: GJP	DATE: 9-26-05
OUTLINE DRAWING		SHT 1.1		

SENSITIVITY IN dB RELATIVE TO 1.0 VOLT/0.1 Pa (N/M²)
FOR CONDITIONS SHOWN BELOW.

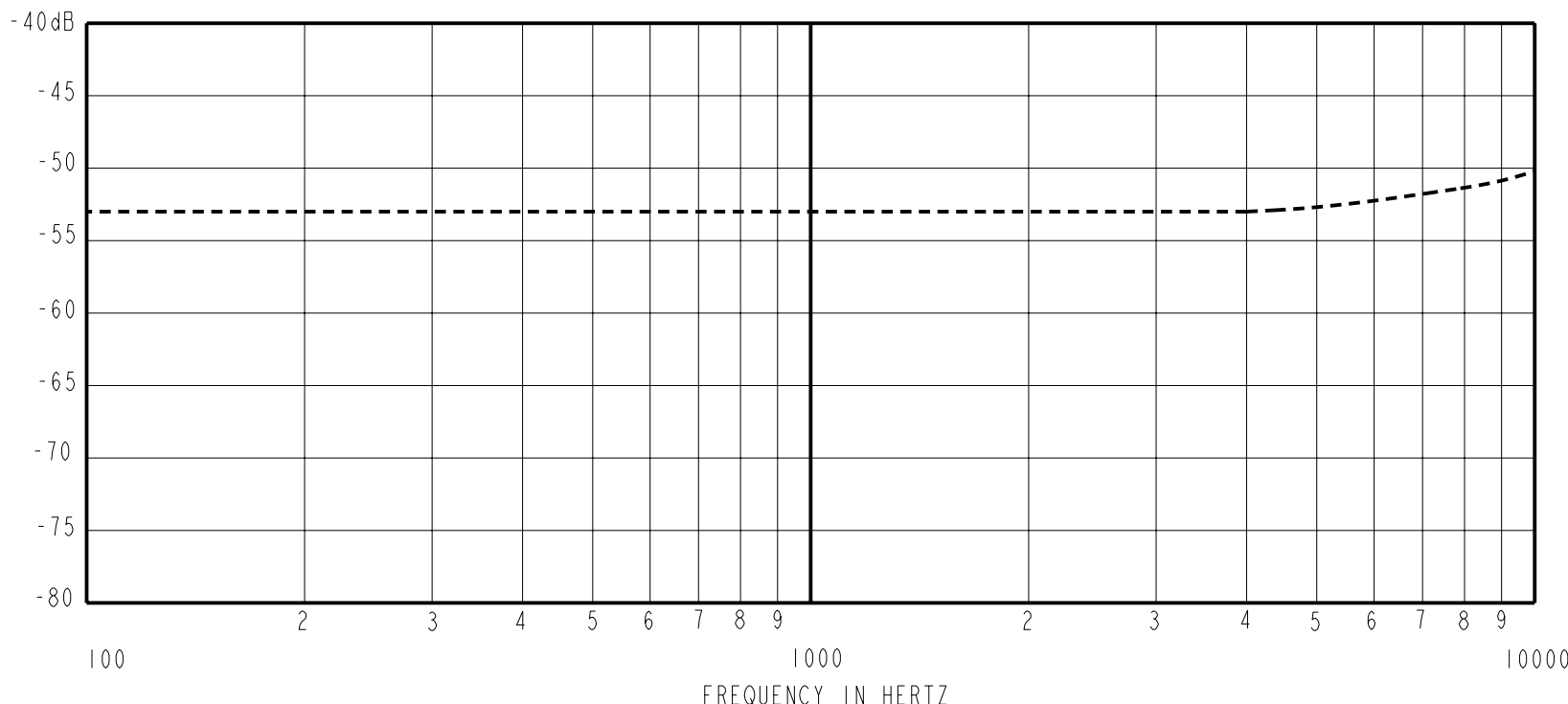

FREQUENCY	SENSITIVITY			DEVICE CONFORMITY	
	MIN.	NOM.	MAX.	RANGE OF DEVIATION FROM 1KHz	
100	---	-53.0	---	-3.0	+3.0
1000	-56.0	-53.0	-50.0	0.0	0.0
10000	---	-50.0	---	-0.0	+6.0

- NOTES:
1. CASE CONNECTED TO NEGATIVE TERMINAL.
 2. MICROPHONE TO BE FUNCTIONAL WITH 1.6 VDC SUPPLY.
 3. TYPICAL SENSITIVITY TO HUMIDITY AT 1000Hz IS 0.06 dB/%RH
 4. SENSITIVITY AND NOISE VALUES INDICATED ON THIS SPECIFICATION ARE VALID AT 50% HUMIDITY.

PORT LOCATION	DC SUPPLY	AMPLIFIER CURRENT DRAIN	SENSITIVITY CHANGE ON REDUCING SUPPLY TO 0.9VDC	"A" WEIGHTED NOISE (1 kHz EQUIV. SPL)	OUTPUT IMPEDANCE OHMS			CAPACITANCE ±50%	
					MIN.	NOM.	MAX.	1-2	1-3
12S	1.3V	50 µA MAX.	3 dB MAX.	28.0 dB MAX.	2800	4400	6800	13pF	13pF

CAPACITANCE PROBE POINTS

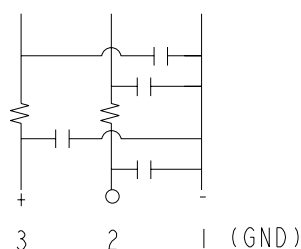

Revision	C.O. #	Implementation Date	RELEASE LEVEL	REVISION
B	M10100967	1-20-06	Released	B
A	M10100781	9-22-05		

KNOWLES ELECTRONICS
ITASCA, ILLINOIS U.S.A.

WHEN TEST LIMITS ARE USED TO ESTABLISH INCOMING INSPECTION ACCEPTANCE/REJECTION CRITERIA, CORRELATION OF TEST EQUIPMENT WITH KNOWLES IS ALSO REQUIRED FOR ELIMINATION OF EQUIPMENT AND TEST METHOD VARIATION

TITLE: **MICROPHONE**
PERFORMANCE SPECIFICATION

FG-23629-C36
SHT 2.1

DR. BY	DATE
DMS	9-15-05
CK. BY	DATE
GJP	9-26-05
APP. BY	DATE
GJP	9-26-05