

# 0.8mm Pitch 4mm Mounting Height S.O. DIMM Socket

## SX6E Series

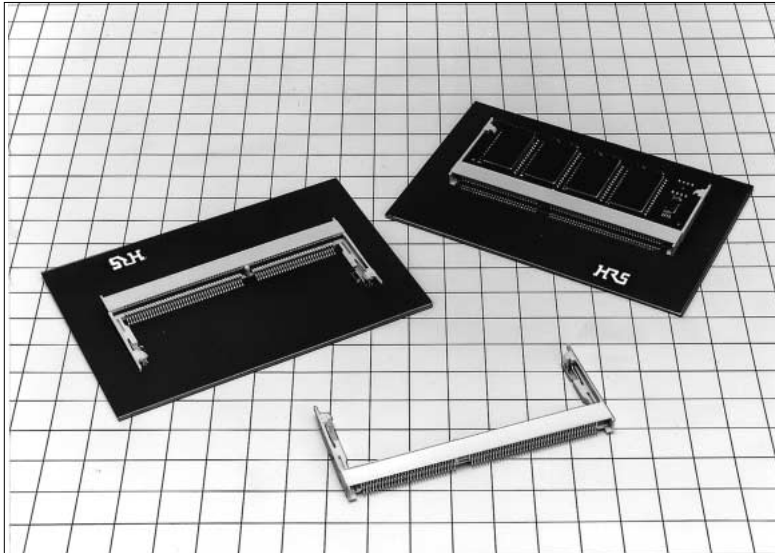

SX6E-144S-0.8SH

## ■ Features

### 1. 144pos. 8 Byte Small Outline DIMM

SX6E series is a 0.8mm pitch parallel SMT type socket applicable to 144pos. 8 Byte Small Outline DIMM standardized by JEDEC.

### 2. 4mm Mounting Height

This socket achieves 4mm mounting height and is designed in a small and light structure.

### 3. 69.6mm Socket Width

This socket achieves 69.6mm width with mold latch and reduces the prohibition area to mount the mother board.

### 4. Easy Insertion and Extraction of Module Board

- (1) One-touch operation to insert the module board slantly and push it downward.
- (2) Widen latches right and left, and the module board will be automatically raised. This mechanism allows easy automatic extraction.
- (3) The original mold twin-latch mechanism allows click sensible Insertion and extraction.

### 5. Solder Reparability

Considering solder reparability, the contact SMT is designed so as to widen the insulation case interval.

## ■ Applications

Note PC, business equipment, measuring instruments, telecommunication equipment, medical equipment, FA, game appliances, EWS

### 4mm Mounting Height, 69.6mm Width Socket

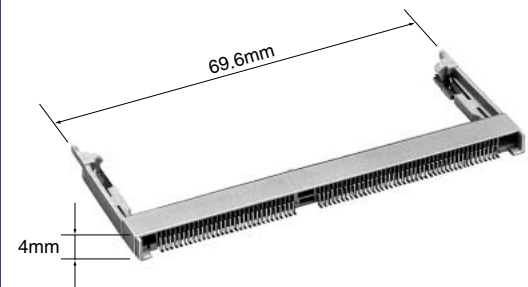

### Easy Insertion and Extraction Operation of Module Board

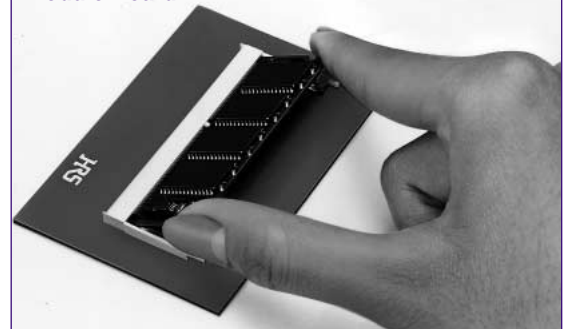

## ■Product Specifications

Rating	Rated Current	-55°C+85°C	Operating Humidity Range	-55°C~+85°C
	Rated Voltage	25V AC		
	Operating Temperature Range	0.3A		

Item	Specification	Condition
1. Contact Resistance	35mΩmin.	Measured at 100mA DC
2. Insulation Resistance	1000MΩ min.	Measured at 250V DC
3. Withstand voltage	Neither short nor breakdown should occur	250V AC energized for 1 minute
4. Meckanical Operation	Contact resistance: 55mΩ max. No part should be damaged, cracked or loosened.	Insulator/Extraction: 30 cycles
5. Vibration	Electrical discontinuity, 1μS max. Contact resistance: 55mΩ max. No part should be cracked, loosened or damaged.	10~55Hz (5 minutes per cycle) and single amplitude 0.75mm in 3 directions for 10 cycles, respectively.
6. Shock	Electrical discontinuity, 1μS max. Contact resistance: 55mΩ max. No part should be cracked, loosened or damaged	Speed: 490m/s, Sustaining time: 11ms Test sine half-wave in 3 directions at 3 cycles, respectively
7. Temperature Cycle	Contact resistance: 55mΩ max. Insulation resistance: 1000MΩ max. No part should be cracked, loosened or damaged.	: 5 cycles under following conditions: Temperature : -55→ +5~35→ +85→ +5~35°C Time : 30→ 10~15→ 30→ 10~15 minutes
8. Humidity, Steady State	Contact resistance: 55mΩ max. Insulation resistance: 1000MΩ max. No part should be cracked, loosened or damaged.	Exposed to temperature 40±2°C and humidity 90~95% for 96 hours
9. Salt spray	Contact resistance: 55mΩ max.	No remarkable corrosion Exposed to salt 5% density water for 48 hours

## ■Material

Part	Material	Finish
Contact	Phosphor copper	Gold plating
Insulator	LCP	UL94V-0
Fitting metal	Phosphor copper	Solder plating

SX6E-144S-0.8SH  
CL530-0303-5

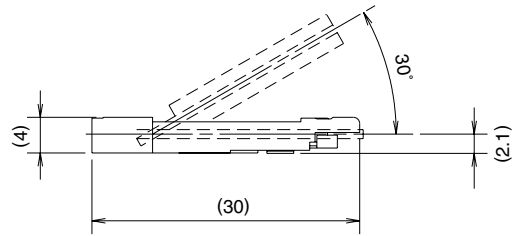
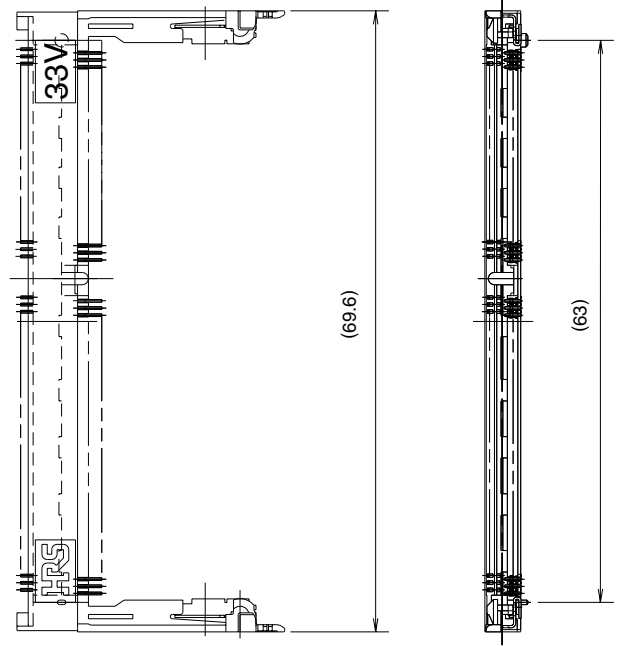
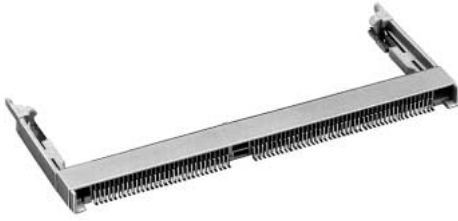

◆ PCB Footprints

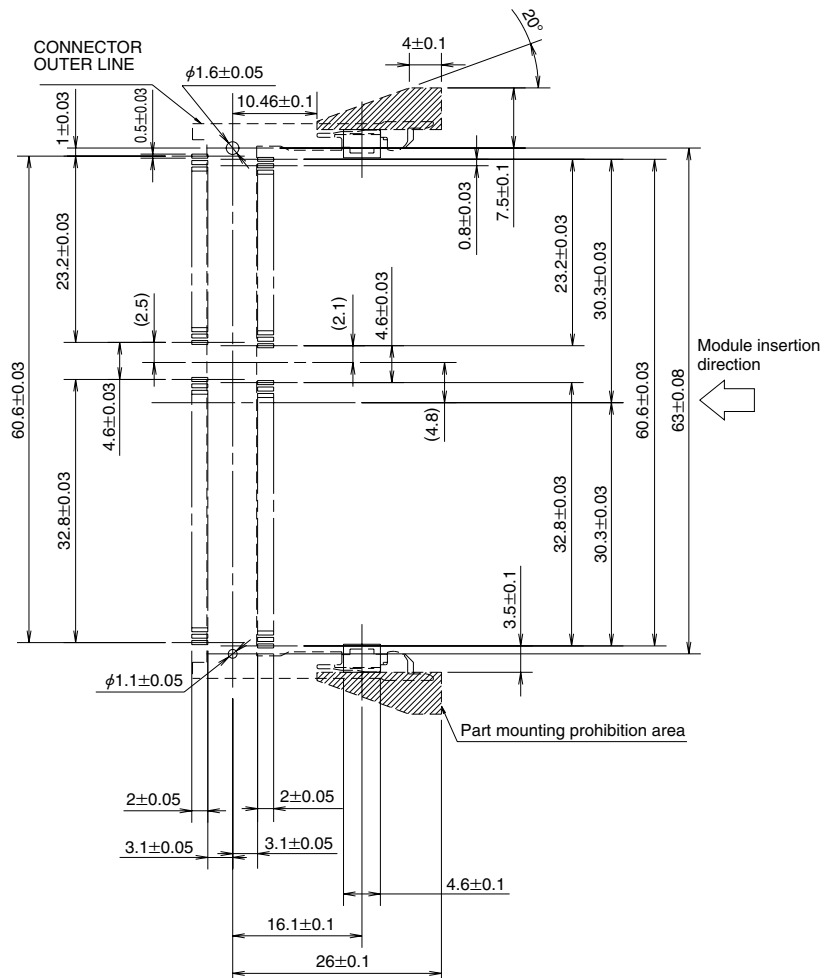

# ◆ Recommended Module Board Dimensions

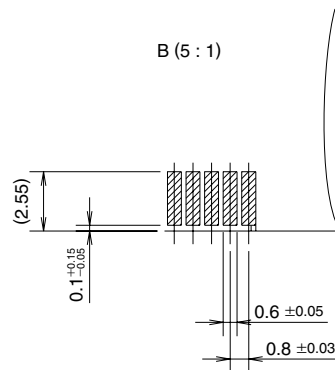
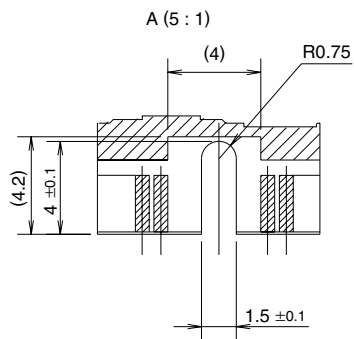
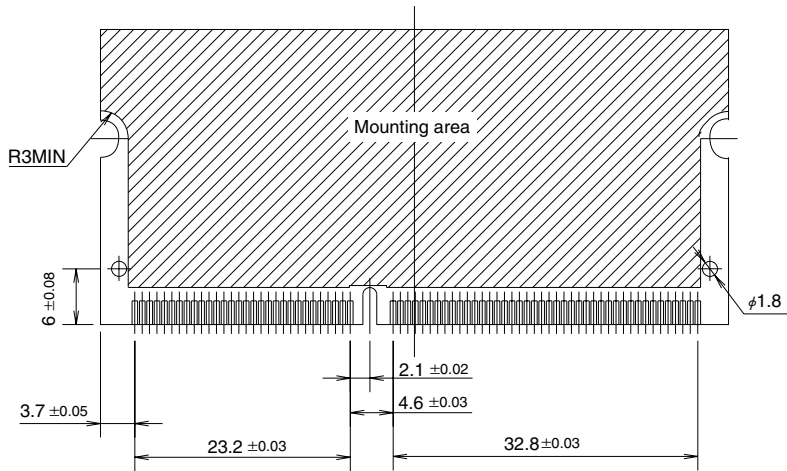
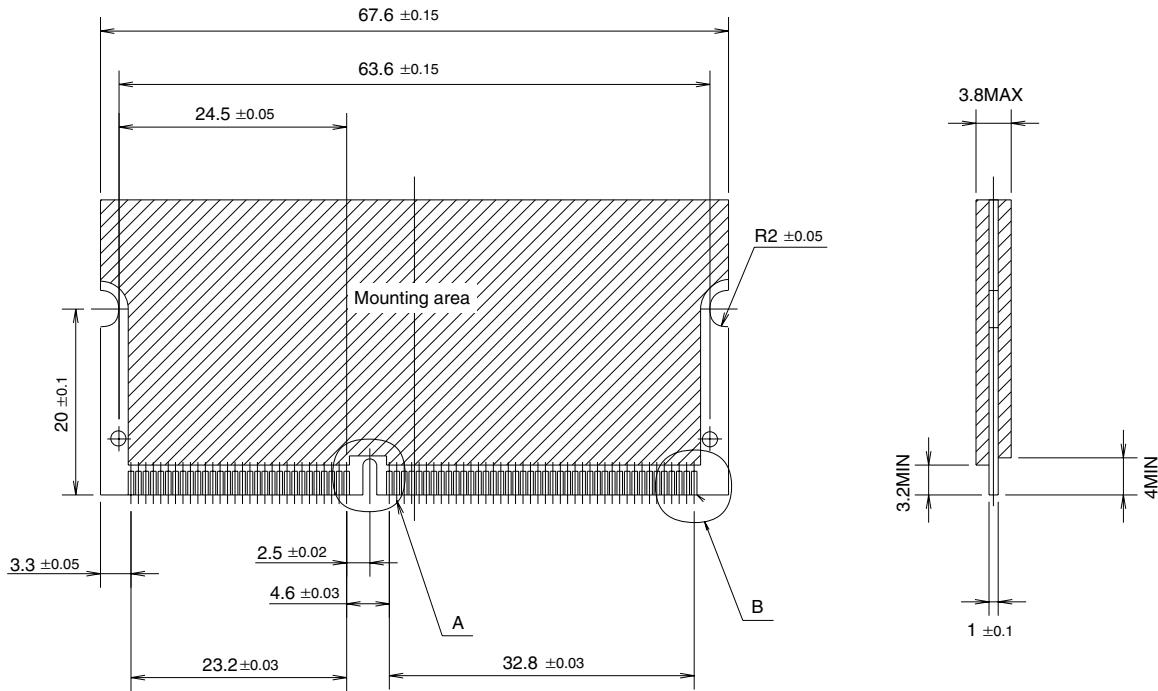

## ◆Precautions for use

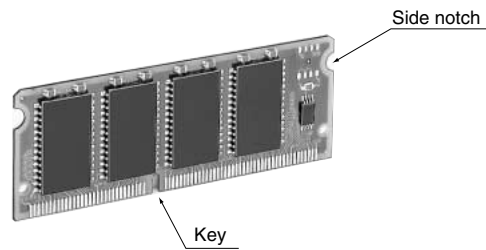
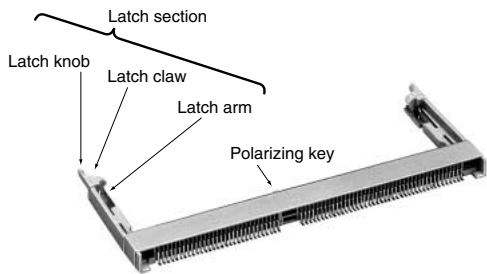

### Procedures for Board Insertion

1. Adjust the socket polarizing key and the board key to the same direction.
2. Insert the board slantly. Moreover, lay the board in parallel to the opening at angle of 20° to 30° , and softly insert the board so as to hit the socket bottom. Stopping insertion halfway will result in improper insertion.
3. Applying the board side notch in parallel to the socket bottom so that the board position cannot be displaced, press the board side notch up, and fix the both socket edges to the latch area. Press the board side notch, and release the notch with a snap "click" tone, if the printed board passes through the latch claw head.

With this action, the board has been completely installed in the socket. At this time, pressing force is equivalent to the extent of turning on the electric product switch. If the stronger pressing force is needed, check whether the direction and depth to insert the board is adequate or not, and then re-push the board.

### Procedures for Board Extraction

Apply the thumb nail to the latch knob at both socket edges. Forcibly widen the latch knobs to right and left ways, and release the latch. Then, draw the board out along the angle where the board is raised.

### Cautions

- The latch has strength enough to endure. However, if force is applied according to other operation methods instead of the Procedures for Handling Sockets, or if further force is given in the state where the module board is raised, products could be damaged. Be sure to observe the Procedures for Handling Sockets.
- The board is designed in compliance with JEDEC "Small Outline DIMM (Dual Inline Memory Module)". However, if other boards are used instead of the recommended module board, or if the mounting product is used for other devices than DRAM memory IC, troubles due to vibration or other failures could occur. If needed, consult the HRS company.
- The recommended module board pad or sharp angle edges could cause failure in contacts. Therefore, it is recommended to offset the tie-bar from the center line, set the internal pad, or remove sharp corners or burrs according to the recommended sizes.
- Don't provide the external contact surface of the module board with the convex/concave and chamfer areas at both edges. Comply with the recommended sizes.
- When the board is mounted or housing is installed, if warpage or flexure has occurred, an excessive load could cause changes in the solder bonding area and the strength. Be sure to check individual points.
- If the board is used under environments where corrosive gas is apt to occur, consult the HRS company.

### Procedures for Board Insertion



### Procedures for Board Extraction



## ◆ Recommended Temperature Profile

### ● IR Reflow: Recommended Temperature Profile (Up to second reflow)

#### ● Manual Soldering

Soldering iron temperature:  $300 \pm 10^\circ\text{C}$

Manual soldering time: 3 seconds max.

This temperature profile is a recommendation.

The temperature may be slightly changed according to solder paste types and amount.

#### ● Setting Condition (Reference)

○ Board

Size : 110×85×1.6 (mm)

Material: Glass epoxy (Grade: FR-4)

○ Solder paste

63Sn/37Pb : (Flux content: 11wt%)

Metal mask thickness: 0.15mm

