

2008/01/16 08:35:06 HK. HORINO

DRAWING FOR REFERENCE: This is subject to change without notice

| 1 | | | | | 2 | | | | | 3 | | | | | 4 | | | | |
|-------|--------------------------|--|--|--|----|------|------|-------|--------------------------|---|--|--|----|------|------|--|--|--|--|
| COUNT | DESCRIPTION OF REVISIONS | | | | BY | CHKD | DATE | COUNT | DESCRIPTION OF REVISIONS | | | | BY | CHKD | DATE | | | | |
| △ | | | | | | | .. | △ | | | | | | | .. | | | | |
| △ | | | | | | | | △ | | | | | | | .. | | | | |
| △ | | | | | | | | △ | | | | | | | .. | | | | |

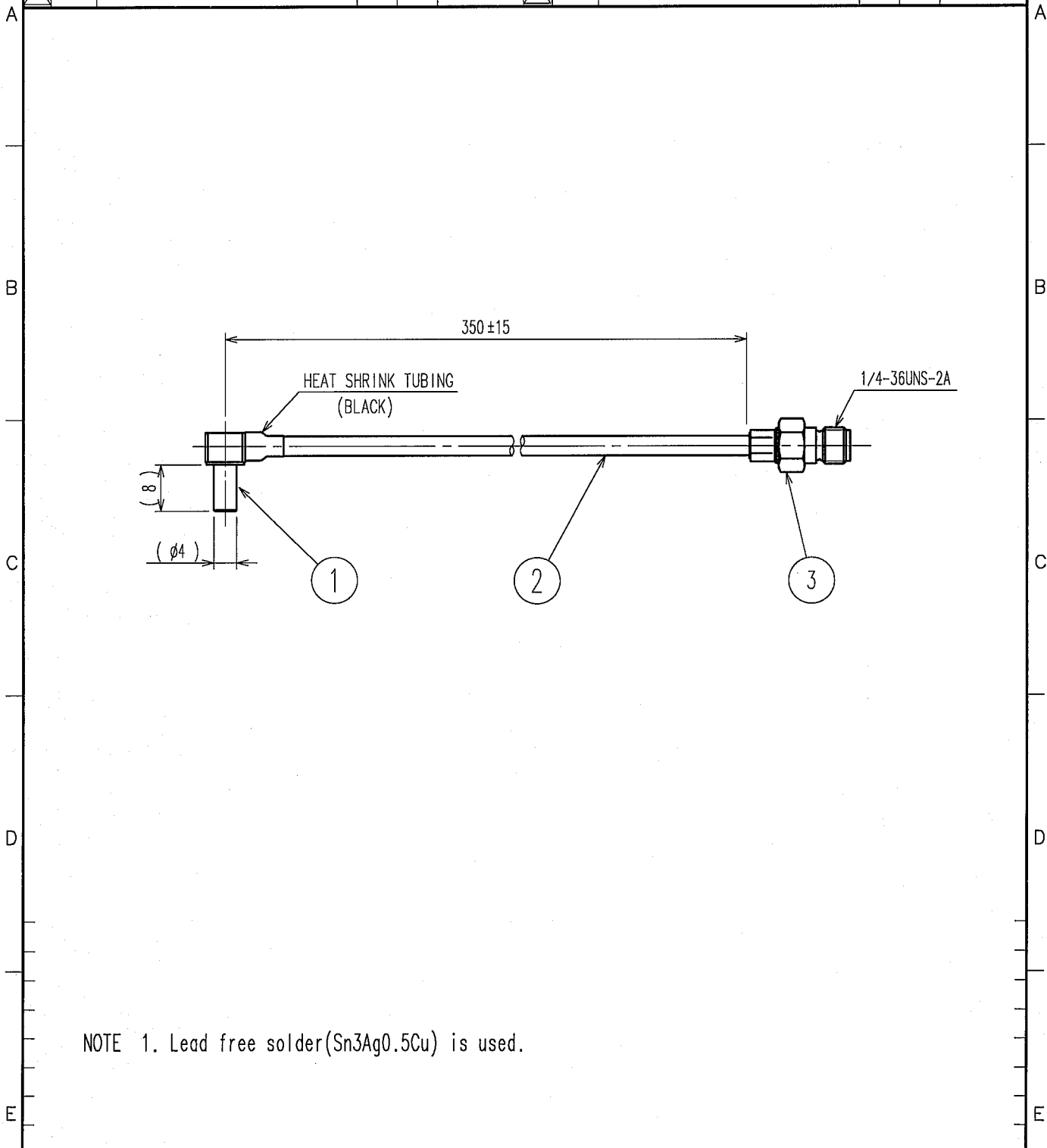

NOTE 1. Lead free solder(Sn3Ag0.5Cu) is used.

| 2 | 1.5D-HQEW | FUJIKURA CO.,LTD | | | |
|-----|----------------|------------------|-----|---------------------|-----------------|
| 1 | MS-162-C(LP)-1 | CL358-0222-4-00 | 3 | HRM-200-1.5WJBN(40) | CL323-0711-7-40 |
| NO. | MATERIAL | FINISH, REMARKS | NO. | MATERIAL | FINISH, REMARKS |

| CODE NO. (OLD) | DRAWN | DESIGNED | CHECKED | APPROVED | RELEASED |
|----------------|------------------------------|------------------------------|----------------------------|--------------------------------|----------|
| | <i>Y. Matsuo</i> '07.6.29 | <i>Y. Matsuo</i> '07.6.29 | <i>R. Kanu</i> '07.6.29 | <i>H. Kawamura</i> '07.6.29 | |

| | | | | | |
|-------------|--------------------------|-------------|--------------|----------|-----|
| | DRAWING NO. | PART NO. | | CODE NO. | 1/1 |
| | SCALE 1 : 1 | EDC4-180704 | | | |
| UNITS mm | HIROSE ELECTRIC CO.,LTD. | | CL362-0130-7 | | |

| |
|-----|
| TO |
| RFD |
| |
| |

