

W541C240 Data Sheet



4-BIT MICROCONTROLLER

Table of Contents-

1.	GENERAL DESCRIPTION	2
2.	FEATURES	2
3.	PIN CONFIGURATION	4
4.	BLOCK DIAGRAM	5
5.	PAD DESCRIPTION	6
6.	ELECTRICAL CHARACTERISTICS.....	7
6.1	Absolute Maximum Ratings	7
6.2	DC Characteristics	7
6.3	AC Characteristics.....	8
7.	APPLICATION CIRCUIT.....	9
8.	REVISION HISTORY	10

1. GENERAL DESCRIPTION

The W541C240 is a high-performance 4-bit microcontroller (μ C) that provides an LCD driver.. The device contains a 4-bit ALU, a 8-bit timers, a divider, a 24×4 LCD driver, and three 4-bit I/O ports. There are also three interrupt sources and 8-level subroutine nesting for interrupt applications. The W541C240 operates on low voltage and very low current and has two power reduction modes, hold mode and stop mode, which help to minimize power dissipation. The W541C240 is suitable for calculators, simple watches and clocks, multiple I/O products, keyboard controllers, speech synthesis LSI controllers, and other products.

2. FEATURES

- Operating voltage: 2.4V to 5.5V (LCD drive voltage: 3.0V or 4.5V)
- Crystal/RC oscillation circuit selectable by code option for system clock
- Crystal oscillator: 32.768 KHz only
- RC oscillator: 1 MHz (maximum)
 - High-frequency (400 KHz to 1 MHz) or low-frequency (below 400 KHz) oscillation option must be determined by the code option.
 - In RC mode, attention must be paid to the high/low frequency oscillation option, because the LCD driver frequency is related to this option.
- Memory
 - 2048 \times 16 bit program ROM (shared with 2K \times 4 bit look-up table)
 - 64 \times 4 bit data RAM (shared with 16 working registers)
 - 24 \times 4 LCD data RAM
- 13 input/output pins
 - Ports for input only: 1 port/4 pins
 - Input/output ports: 2 ports/8 pins
 - MFP output pin: 1 pin (MFP)
 - Do not be floating when it is as input or output open-drain (NMOS type).
- Power-down mode
 - Hold function: no operation (except for oscillator)
 - Stop function: no operation (including oscillator)
- Three types of interrupts
 - Two internal interrupts (Divider 0, Timer 1)
 - One external interrupts (Port RC)



- LCD driver output
 - 24 segment × 4 common
 - Static, 1/2 duty (1/2 bias), 1/3 duty (1/2 or 1/3 bias), 1/4 duty (1/3 bias) driving mode can be selected
- MFP output pin
 - Output is software selectable as modulating or nonmodulating frequency
 - Works as frequency output specified by Timer 1
- Built-in 14-bit clock frequency divider circuit
- One built-in 8-bit programmable countdown timers
 - Timer 1: Offers auto-reload function and one of two internal clock frequencies (Fosc or Fosc/64) can be selected (output through MFP pin)
- Built-in 18/14-bit watchdog timer selectable for system reset
- Powerful instruction set: 100 instructions
- 8-level subroutine (include interrupt) nesting
- Up to 4 μ S instruction cycle (with 1 MHz operating frequency)
- Chip On Board available / Packaged in 64-pin QFP



3. PIN CONFIGURATION

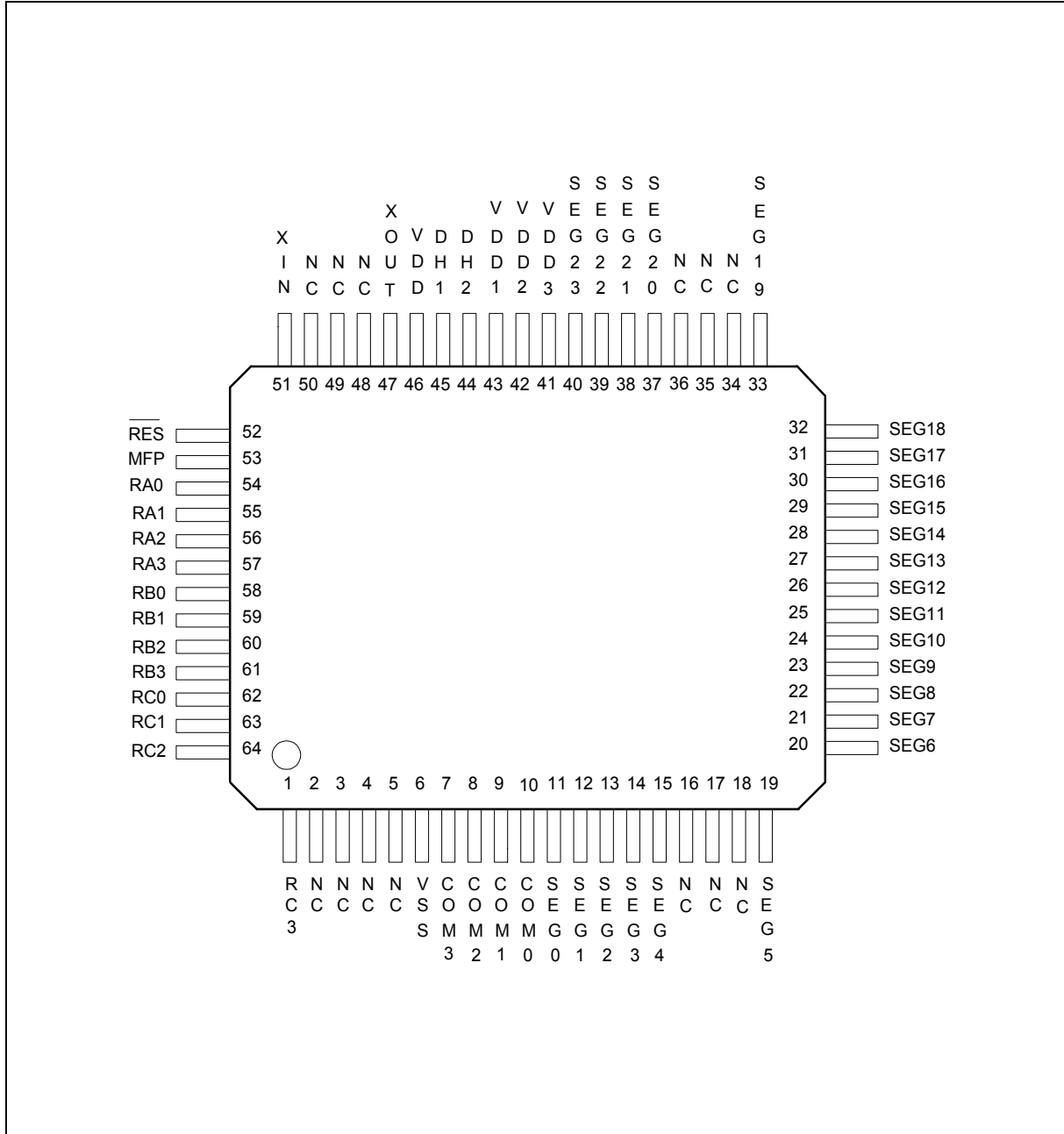



4. BLOCK DIAGRAM

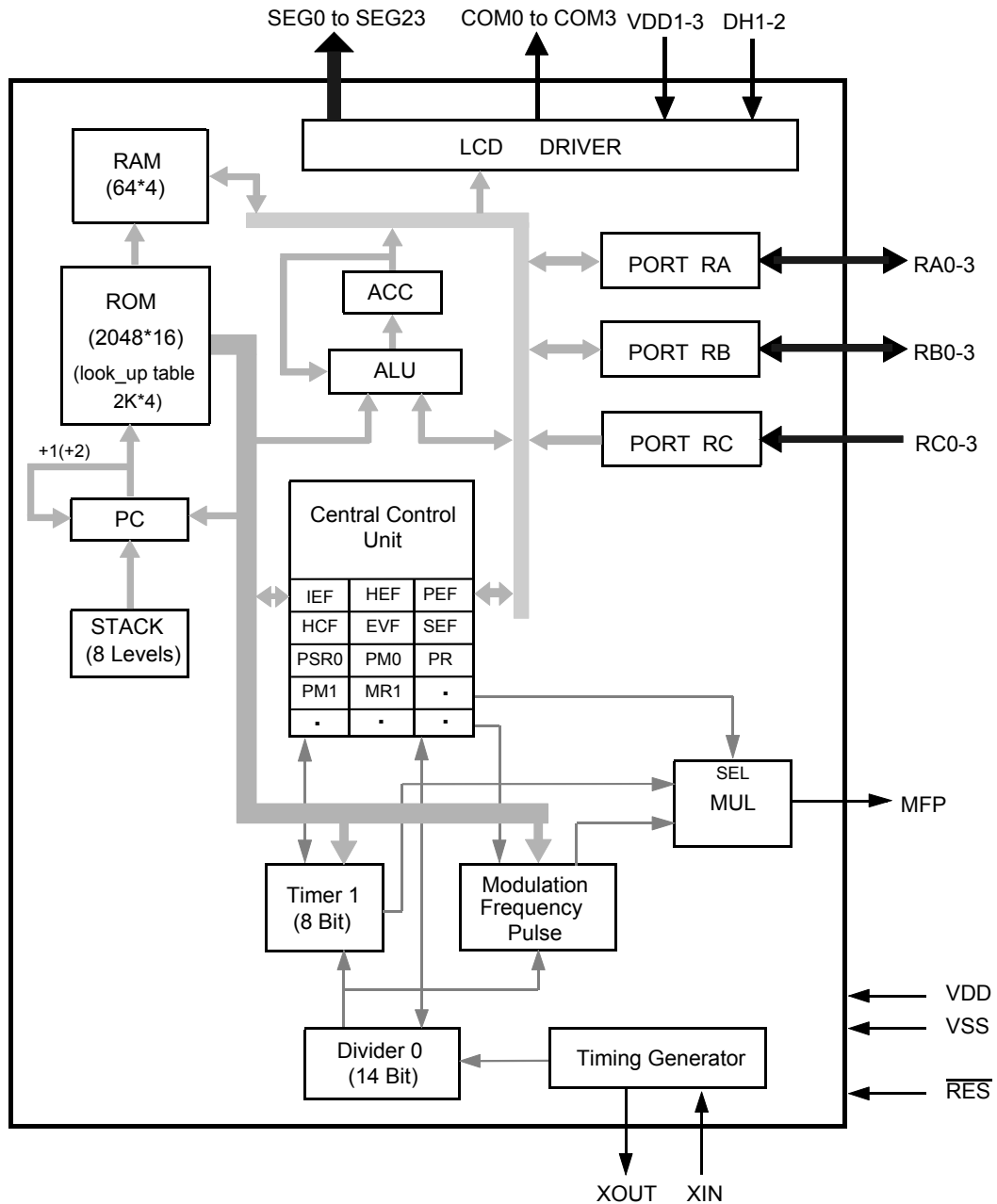



5. PIN DESCRIPTION

SYMBOL	I/O	FUNCTION																									
XIN	I	Input pin for oscillator. Connected to crystal or resistor to generate system clock by code option. External 10~20pF capacitor uses to get accurate freq in crystal mode..																									
XOUT	O	Output pin for oscillator. Connected to crystal or resistor to generate system clock by code option. 20pF capacitor is built in internal for crystal mode..																									
RA0–RA3	I/O	Input/Output port. Input/output mode specified by port mode 1 register (PM1).																									
RB0–RB3	I/O	Input/Output port. Input/output mode specified by port mode 2 register (PM2).																									
RC0–RC3	I	4-bit port for input only. Each pin has an independent interrupt capability.																									
MFP	O	Output pin only. This pin can output modulating or nonmodulating frequency, or Timer 1 clock output specified by mode register 1 (MR1).																									
$\overline{\text{RES}}$	I	System reset pin with pull-high resistor.																									
SEG0–SEG23	O	LCD segment output pins.																									
COM0–COM3	O	LCD common signal output pins. <table border="1" style="margin-left: 20px;"> <thead> <tr> <th></th> <th>Static</th> <th>1/2 Duty</th> <th>1/3 Duty</th> <th>1/4 Duty</th> </tr> </thead> <tbody> <tr> <td>COM0</td> <td>Used</td> <td>Used</td> <td>Used</td> <td>Used</td> </tr> <tr> <td>COM1</td> <td>Not Used</td> <td>Used</td> <td>Used</td> <td>Used</td> </tr> <tr> <td>COM2</td> <td>Not Used</td> <td>Not Used</td> <td>Used</td> <td>Used</td> </tr> <tr> <td>COM3</td> <td>Not Used</td> <td>Not Used</td> <td>Not Used</td> <td>Used</td> </tr> </tbody> </table> <p>The LCD alternating frequency can be selected by code option.</p>		Static	1/2 Duty	1/3 Duty	1/4 Duty	COM0	Used	Used	Used	Used	COM1	Not Used	Used	Used	Used	COM2	Not Used	Not Used	Used	Used	COM3	Not Used	Not Used	Not Used	Used
	Static	1/2 Duty	1/3 Duty	1/4 Duty																							
COM0	Used	Used	Used	Used																							
COM1	Not Used	Used	Used	Used																							
COM2	Not Used	Not Used	Used	Used																							
COM3	Not Used	Not Used	Not Used	Used																							
DH1, DH2	I	Connection terminals for voltage doubler (halver) capacitor.																									
VDD1, VDD2, VDD3	I	Positive (+) supply voltage terminal. Refer to Functional Description.																									
VDD	I	Positive power supply (+).																									
VSS	I	Negative power supply (-).																									



6. ELECTRICAL CHARACTERISTICS

6.1 Absolute Maximum Ratings

PARAMETER	RATING	UNIT
Supply Voltage to Ground Potential	-0.3 to +7.0	V
Applied Input/Output Voltage	-0.3 to +7.0	V
Power Dissipation	120	mW
Ambient Operating Temperature	0 to +70	°C
Storage Temperature	-55 to +150	°C

Note: Exposure to conditions beyond those listed under Absolute Maximum Ratings may adversely affect the life and reliability of the device.

6.2 DC Characteristics

(V_{DD}-V_{SS} = 3.0V, F_{osc} = 32.768 KHz, T_A = 25° C; unless otherwise specified)

PARAMETER	SYM.	CONDITIONS	MIN.	TYP.	MAX.	UNIT
Op. Voltage	V _{DD}	-	2.4	-	5.5	V
Op. Current (Crystal type)	I _{OP1}	No load (Ext-V)	-	8	15	μA
Op. Current (RC type)	I _{OP2}	No load (Ext-V)	-	35	60	μA
Hold Current (Crystal type)	I _{HM1}	Hold mode No load (Ext-V)	-	4	6	μA
Hold Current (RC type)	I _{HM2}	Hold mode No load (Ext-V)	-	16	40	μA
Stop Current (Crystal type)	I _{SM1}	Stop mode No load (Ext-V)	-	0.1	2	μA
Stop Current (RC type)	I _{SM2}	Stop mode No load (Ext-V)	-	0.1	2	μA
Input Low Voltage	V _{IL}	-	V _{SS}	-	0.3 V _{DD}	V
Input High Voltage	V _{IH}	-	0.7 V _{DD}	-	V _{DD}	V
MFP Output Low Voltage	V _{ML}	I _{OL} = 3.5 mA	-	-	0.4	V
MFP Output High Voltage	V _{MH}	I _{OH} = -3.5 mA	2.4	-	-	V
Port RA, RB Output Low Voltage	V _{ABL}	I _{OL} = 2.0 mA	-	-	0.4	V
Port RA, RB Output high Voltage	V _{ABH}	I _{OH} = -2.0 mA	2.4	-	-	V
LCD Supply Current	I _{LCD}	All Seg. On	-	-	6	μA



DC Characteristics, continued

PARAMETER	SYM.	CONDITIONS	MIN.	TYP.	MAX.	UNIT
SEG0–SEG23 Sink Current (work as LCD output pins)	IOL	VOL = 0.4V VLCD = 0.0V	4	-	-	μA
SEG0–SEG23 Drive Current (work as LCD output pins)	IOH	VOH = 2.4V VLCD = 3.0V	15	-	-	μA
Input Port Pull-up Resistor	RC	Port RC	100	350	1000	KΩ
$\overline{\text{RES}}$ Pull-up Resistor	RRES	-	20	100	500	KΩ

6.3 AC Characteristics

(VDD–VSS = 3.0V, TA = 25° C; unless otherwise specified)

PARAMETER	SYM.	CONDITIONS	MIN.	TYP.	MAX.	UNIT
Op. Frequency	Fosc	RC type	-	-	1000	KHz
		Crystal type (Option low-speed type)	-	32.768	-	
Frequency Deviation by Voltage Drop for RC Oscillator	$\frac{\Delta f}{f}$	$\frac{f(3V) - f(2.4V)}{f(3V)}$	-	-	10	%
Instruction Cycle Time	Ti	One machine cycle	-	4/Fosc	-	mS
Reset Active Width	TRAW	FOSC = 32.768 KHz	1	-	-	μS

7. APPLICATION CIRCUIT

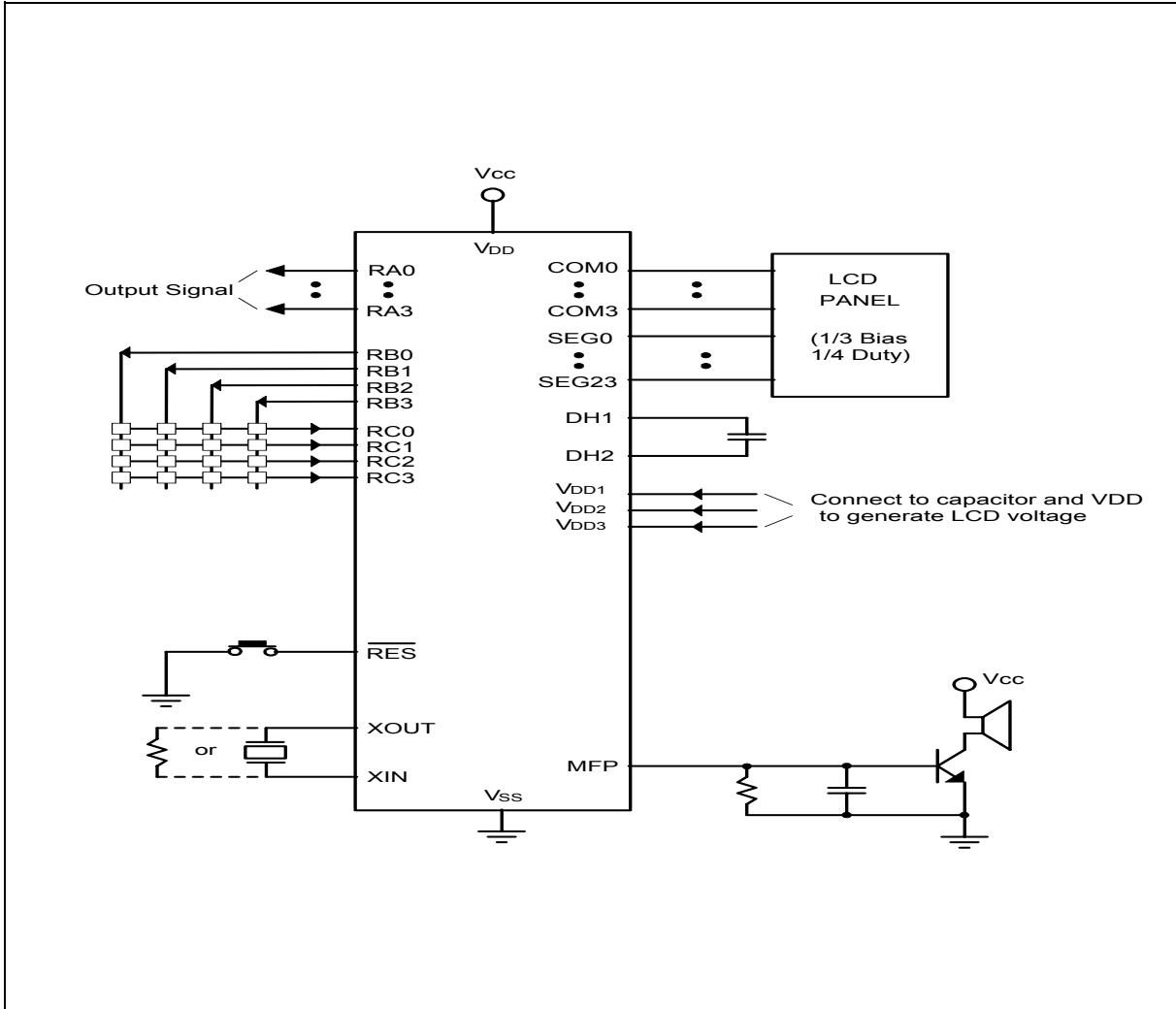



8. REVISION HISTORY

REVISION	DATE	DESCRIPTION
A1	May 30, 2003	Initial Issued



Headquarters

No. 4, Creation Rd. III,
Science-Based Industrial Park,
Hsinchu, Taiwan
TEL: 886-3-5770066
FAX: 886-3-5665577
<http://www.winbond.com.tw/>

Taipei Office

9F, No.480, Rueiguang Rd.,
Neihu District, Taipei, 114,
Taiwan, R.O.C.
TEL: 886-2-8177-7168
FAX: 886-2-8751-3579

Winbond Electronics Corporation America

2727 North First Street, San Jose,
CA 95134, U.S.A.
TEL: 1-408-9436666
FAX: 1-408-5441798

Winbond Electronics Corporation Japan

7F Daini-ueno BLDG, 3-7-18
Shinyokohama Kohoku-ku,
Yokohama, 222-0033
TEL: 81-45-4781881
FAX: 81-45-4781800

Winbond Electronics (Shanghai) Ltd.

27F, 2299 Yan An W. Rd. Shanghai,
200336 China
TEL: 86-21-62365999
FAX: 86-21-62365998

Winbond Electronics (H.K.) Ltd.

Unit 9-15, 22F, Millennium City,
No. 378 Kwun Tong Rd.,
Kowloon, Hong Kong
TEL: 852-27513100
FAX: 852-27552064

*Please note that all data and specifications are subject to change without notice.
All the trade marks of products and companies mentioned in this data sheet belong to their respective owners.*