

UTC LP2950/2951 LINEAR INTEGRATED CIRCUIT

100 mA LOW-DROPOUT VOLTAGE REGULATOR

DESCRIPTION

The UTC LP2950/2951 is a monolithic integrated voltage regulator with low dropout voltage, and low quiescent current. It includes many features that suitable for different applications. Available in 3-pin TO-92, DIP-8 and SOP-8 packages.

FEATURES

- *High accuracy 2.5, 3.0, 3.3, 3.6 or 5V fixed output for TO-92, SOP-8 package.
- *Extremely low quiescent current and dropout voltage.
- *Extremely tight load and line regulation.
- *Current and thermal limiting.
- *Very low temperature coefficient.
- *Logic controlled shutdown and error flag available for DIP and SOP package.
- *Output voltage programmable for DIP and SOP package.

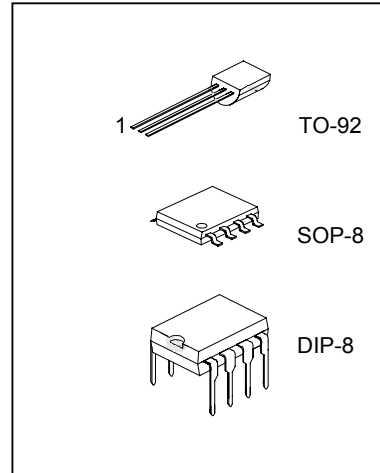

APPLICATIONS

- *Battery powered equipment.
- *High efficient linear regulator down to 1.24V.
- *Cellular phones.

ORDERING INFORMATION

PART NUMBER	TEMPERATURE RANGE	PACKAGE	ACCURACY
UTC LP2950-5.0	-40 ~ +125°C	3-Pin TO-92 plastic	2.0%
UTC LP2950-3.0	-40 ~ +125°C	3-Pin TO-92 plastic	1.0%
UTC LP2950-3.3	-40 ~ +125°C	3-Pin TO-92 plastic	1.0%
UTC LP2950-3.6	-40 ~ +125°C	3-Pin TO-92 plastic	2.0%
UTC LP2950-2.5	-40 ~ +125°C	3-Pin TO-92 plastic	1.0%
UTC LP2950-5.0	-40 ~ +125°C	8-Pin SOP-8 plastic	2.0%
UTC LP2950-3.0	-40 ~ +125°C	8-Pin SOP-8 plastic	1.0%
UTC LP2950-3.3	-40 ~ +125°C	8-Pin SOP-8 plastic	1.0%
UTC LP2951	-40 ~ +125°C	8-Pin SOP-8 plastic	2.0%
UTC LP2951	-40 ~ +125°C	8-Pin DIP-8 plastic	2.0%

UTC LP2950/2951 LINEAR INTEGRATED CIRCUIT

PIN CONFIGURATIONS

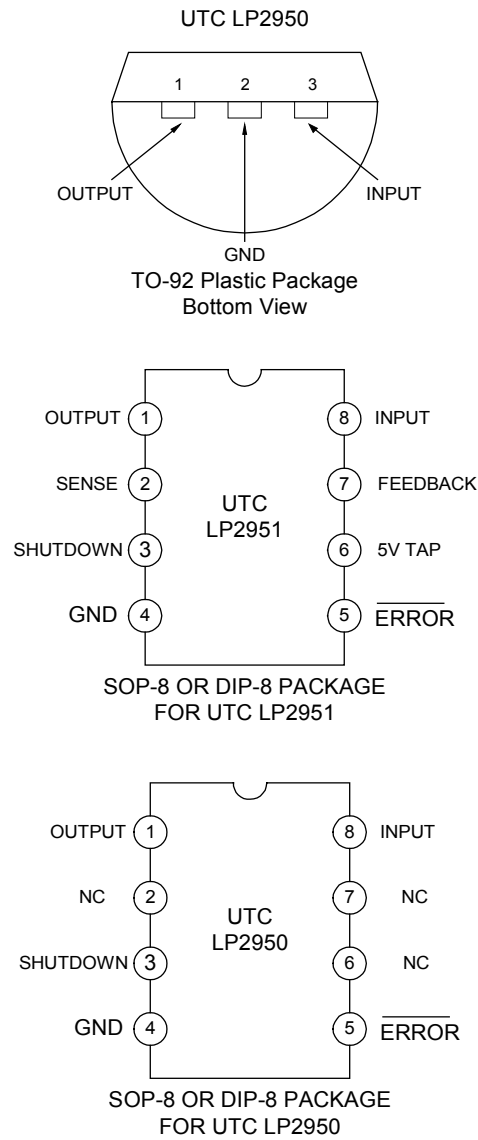
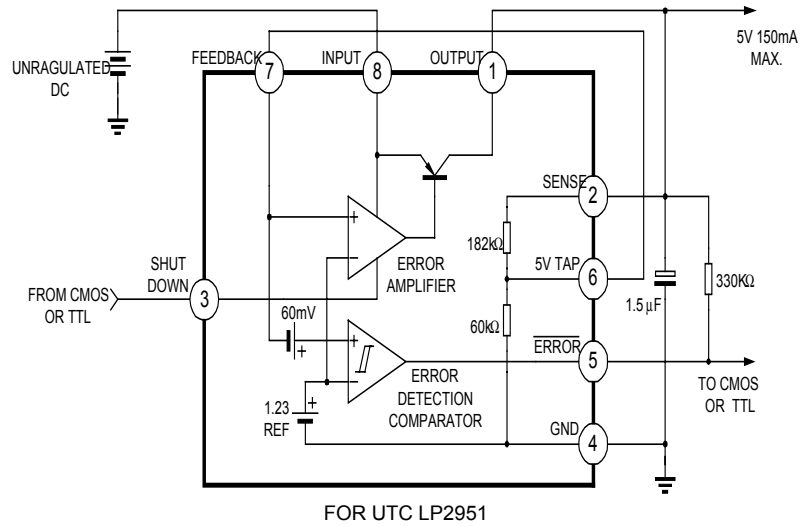

Fig.1

UTC LP2950/2951 LINEAR INTEGRATED CIRCUIT

BLOCK DIAGRAM



ABSOLUTE MAXIMUM RATINGS

PARAMETER	SYMBOL	VALUE	UNIT
Supply Voltage	V _{cc}	-0.3~+18	V
Feedback Voltage	V _{feedback}	-1.5~+18	V
Shutdown Voltage	V _{shutdown}	-0.3~+18	V
Comparator Output Voltage	V _{co}	-0.3~+18	V
Storage Temperature	T _{str}	-65~+150	°C
Operating Junction Temperature	T _J	-40~+125	°C

UTC LP2950/2951 LINEAR INTEGRATED CIRCUIT

ELECTRICAL CHARACTERISTICS

(Tested at $T_J=25^{\circ}\text{C}$, $V_{IN}=6\text{V}$, $I_L=100\mu\text{A}$ and $C_L=1\mu\text{F}$, unless otherwise specified)

PARAMETER	PART NUMBER	TEST CONDITION	MIN.	TYP.	MAX.	UNIT	
Output Voltage	UTC LP2950-2.5	$T_J=25^{\circ}\text{C}$	2.47	2.5	2.53	V	
	UTC LP2950-3.0		2.97	3.0	3.03		
	UTC LP2950-3.3		3.27	3.3	3.33		
	UTC LP2950-3.6		3.53	3.6	3.67		
	UTC LP2950-5.0		4.90	5.0	5.10		
	UTC LP2951		(note 1)				
	UTC LP2950-2.5		$-25^{\circ}\text{C}\leq T_J\leq +85^{\circ}\text{C}$	2.47	2.5		2.53
UTC LP2950-3.0	2.97	3.0		3.03			
UTC LP2950-3.3	3.27	3.3		3.33			
UTC LP2950-3.6	3.53	3.6		3.67			
UTC LP2950-5.0	4.90	5.0		5.10			
UTC LP2951	(note 1)						
Output Voltage	UTC LP2950-2.5	$100\mu\text{A}\leq I_L\leq 100\text{mA}$ $T_J\leq T_J(\text{max})$		2.47	2.5	2.53	V
	UTC LP2950-3.0		2.97	3.0	3.03		
	UTC LP2950-3.3		3.27	3.3	3.33		
	UTC LP2950-3.6		3.53	3.6	3.67		
	UTC LP2950-5.0		4.90	5.0	5.10		
	UTC LP2951		(note 1)				
	Output Voltage Temperature Coefficient				20		
Line Regulation		$6\text{V}\leq V_{IN}\leq 18\text{V}$	0.03	0.1	0.2	%	
Load Regulation		$100\mu\text{A}\leq I_L\leq 100\text{mA}$	0.04	0.1	0.2	%	
Dropout Voltage		$I_L=100\mu\text{A}$	50	80	150	mV	
		$I_L=100\text{mA}$ (note 2)	380	450	600		
Ground Current		$I_L=100\mu\text{A}$	75	120	140	μA	
		$I_L=100\text{mA}$	8	12	14	mA	
Dropout Ground Current		$V_{IN}=4.5\text{V}$, $I_L=100\mu\text{A}$	110	170	200	μA	
Current Limit		$V_{out}=0$	160	200	220	mA	
Output Noise 10Hz to 100KHz		$C_L=1\mu\text{F}$			430	μV	
		$C_L=200\mu\text{F}$			160		
		$C_L=3.3\mu\text{F}$			100		
		(Bypass=0.01 μF pins 7 to (utc2951))					
For LP2951 8-Pin version only							
Reference Voltage			1.22	1.235	1.25	V	
Reference Voltage		(Note 4)	1.19		1.27	V	
Feedback pin Bias Current				20	40	nA	
Reference Voltage Temperature Coefficient				50		ppm/ $^{\circ}\text{C}$	
Feedback Bias Current temperature Coefficient				0.1		nA/ $^{\circ}\text{C}$	

UTC LP2950/2951 LINEAR INTEGRATED CIRCUIT

PARAMETER	PART NUMBER	TEST CONDITION	MIN.	TYP.	MAX.	UNIT
Error Comparator						
Output Leakage Current		V _{OH} =18V			1	μA
Output Low Voltage		V _{IN} =4.5V I _{OL} =400μA			250	mV
Upper Threshold Voltage		(Note 3)	3.2			%V _O
Lower Threshold Voltage		(Note 3)			7.6	%V _O
Hysteresis		(Note 3)		15		mV
Shutdown Input						
Input Logic Voltage		Low(Regulator ON) High(Regulator OFF)	2.0	1.3	0.70	V
Shutdown Pin Input Current		V _{shutdown} =2.4V		30	50	μA
		V _{shutdown} =18V		450	600	μA
Regulator Output Current Shutdown		V _{shutdown} >=2V, V _{IN} <=18V, V _{out} =0, Feedback pin tied to 5V Tap.		3	10	μA

Note 1: Additional conditions for 8-pin versions are feedback tied to 5V Tap and Output tied to Output Sense (V_{out}=5V) and V_{shutdown}<=0.8V.

Note 2: Dropout Voltage is defined as the input to output differential at which the output voltage drops 100mV below its nominal value measured at 1V differential.

Note 3: Comparator thresholds are expressed in terms of percentage value of voltage output.

Note 4: V_{ref}≤V_{out}≤(V_{in}-1V), 2.3V≤V_{in}≤30V, 100μA≤I_L≤100mA, T_J≤T_{JMAX}

UTC LP2950/2951 LINEAR INTEGRATED CIRCUIT

APPLICATION CIRCUIT (10 Ampere Low Dropout Regulator)

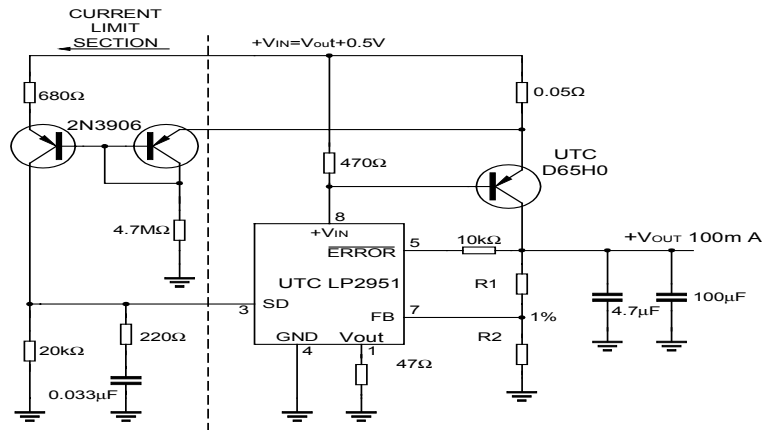

$$V_{out} = 1.23V * (1 + R1/R2)$$

For 5V output use internal resistors. Wire pin 6 to 7 and wire pin 2 to +Vout

Fig.2

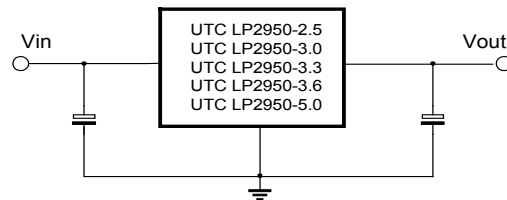

Fig.3

UTC LP2950/2951 LINEAR INTEGRATED CIRCUIT

TYPICAL PERFORMANCE CHARACTERISTICS

