

CMOS 4-BIT MICROCONTROLLER

**TMP47P400VN**  
**TMP47P400VF**

The 47P400V is the system evaluation LSI of 47C200B/400B with 32K bits one-time PROM. The 47P400V programs / verifies using an adapter socket to connect with PROM programmer, as it is in TMM2764AD. In addition, the 47P400V and the 47C200B/400B are pin compatible. The 47P400V operates as the same as the 47C200B/400B by programming to the internal PROM.

PART No.	ROM	RAM	PACKAGE	ADAPTER SOCKET
TMP47P400VN	OTP	256 x 4-bit	SDIP42-P-600-1.78	BM1118
TMP47P400VF	4096 x 8-bit		QFP44-P-1414-0.80D	BM1125

**PIN ASSIGNMENT (TOP VIEW)**

SDIP42-P-600-1.78

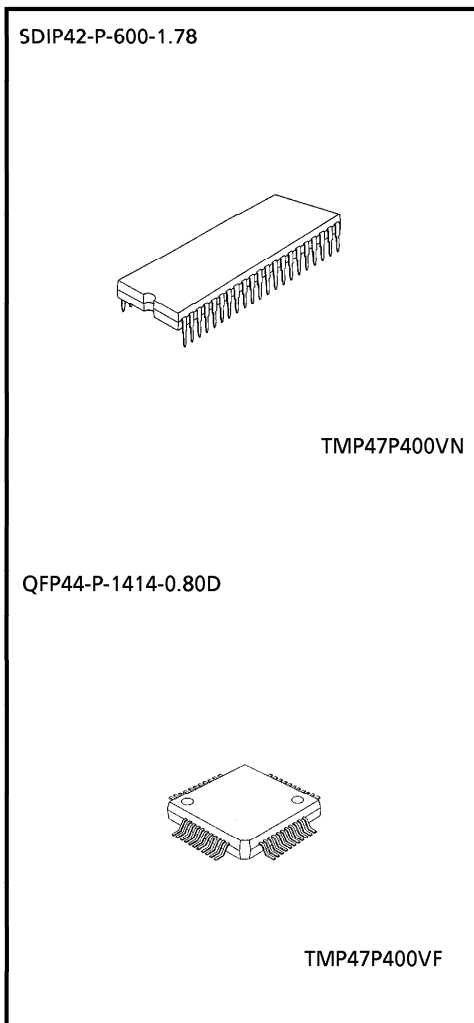
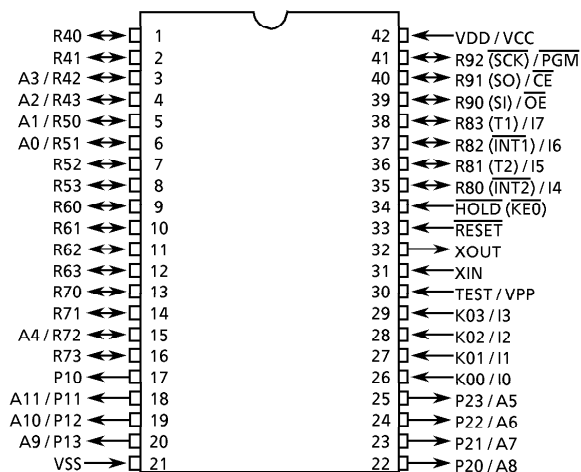

QFP44-P-1414-0.80D

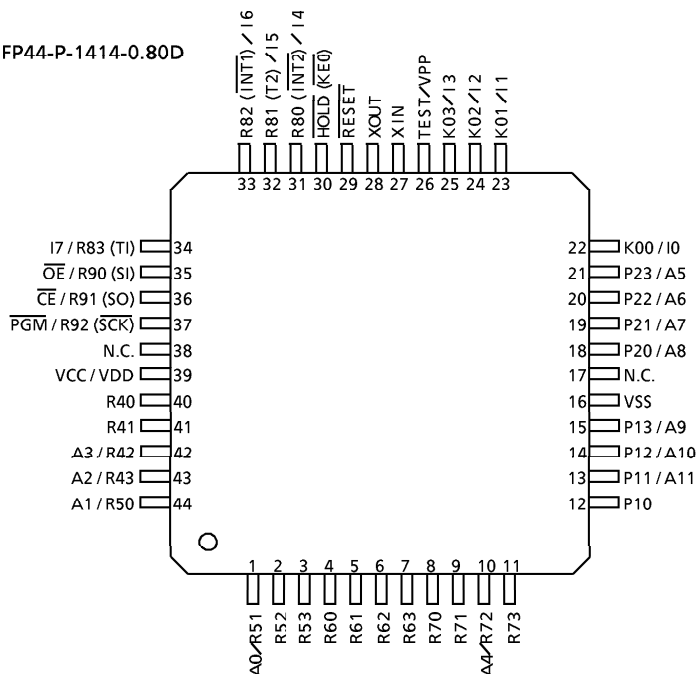

**PIN FUNCTION**

The 47P400V has MCU mode and PROM mode.

(1) MCU mode

The 47C200B/400B and the 47P400V are pin compatible (TEST pin for out-going test. Be fixed to low level).

(2) PROM mode

PIN NAME	Input/Output	FUNCTIONS	PIN NAME (MCU MODE)
A11 to A9	Input	Address inputs	P11 to P13
A8 to A5			P20 to P23
A4			R72
A3 , A2			R42 , R43
A1 , A0			R50 , R51
I7 to I4	I/O	Data inputs / outputs	R83 to R80
I3 to I0			K03 to K00
$\overline{\text{PGM}}$	Input	Program control input	R92
$\overline{\text{CE}}$		Chip Enable input	R91
$\overline{\text{OE}}$		Output Enable input	R90
VPP	Power supply	+ 12.5 V / 5 V (Program supply voltage)	TEST
VCC		+ 5 V	VDD
VSS		0 V	VSS
P10	Output	Open or Be fixed to low level.	
R41 , R40	I/O	Be fixed to low level	
R53 , R52			
R63 to R60			
R70, R71, R73			
$\overline{\text{RESET}}$	Input	PROM mode setting pins. Be fixed to low level.	
HOLD	Input		
XIN	Input	Resonator connecting pins.	
XOUT	Output		

**OPERATIONAL DESCRIPTION**

The following is an explanation of hardware configuration and operation in relation to the 47P400V. The 47P400V is the same as the 47C200B/400B except that an OTP is used instead of a Mask ROM.

**1. OPERATION MODE**

The 47P400V has an MCU mode and a PROM mode.

**1.1 MCU Mode**

The MCU mode is set by fixing the TEST / VPP pin at the "L" level. Operation in the MCU mode is the same as for the 47C200B/400B, except that the TEST / VPP pin does not have pull-down resistor and cannot be used open.

**1.1.1 Program Memory**

The program storage area is the same as for the 47C200B/400B. Data conversion tables must be set in two locations when using the 47P400V to check 47C200B operation.

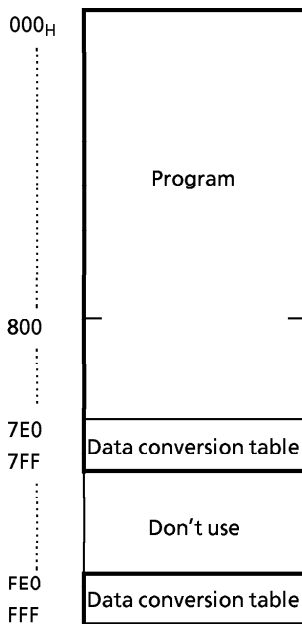

(a) 47C200B

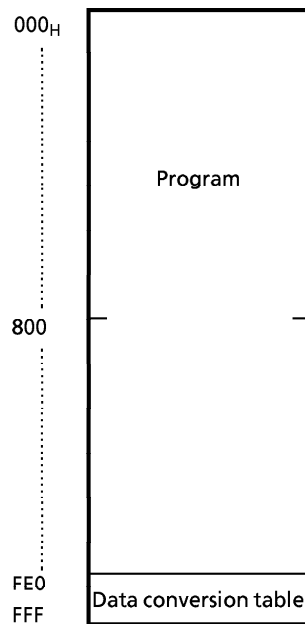

(b) 47C400B

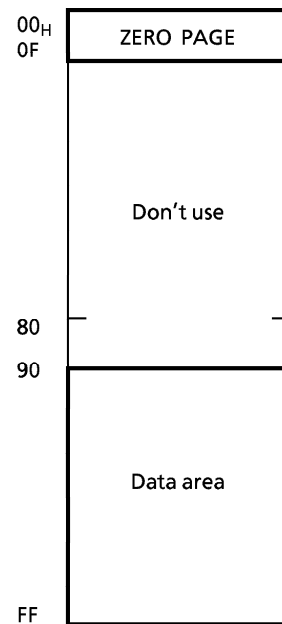

(In case of 47C200B)

Figure 1-1. Program area (RAM)

Figure 1-2. Shared RAM address (RAM)

**1.1.2 Data Memory**

The 47P400V has 256 × 4-bit data memory. When using the 47P400V as a 47C200B evaluator, programming should be performed assuming that the RAM is assigned to addresses 00 to 0FH and 90 to FFH as show in figure 1-2 by considering the application software evaluation.

1.1.3 Input/Output Circuitry

(1) Control pins

This is the same as for the 47C200B/400B except that there is no built-in pull-down resistance for the TEST pin.

(2) I/O Ports

The input/output circuit of the 47P400V is the same as I/O code FA of the 47C200B/400B. External resistance, for example, is required when using as evaluator of other I/O codes (FB to FF) (Refer to Figure 1-3).

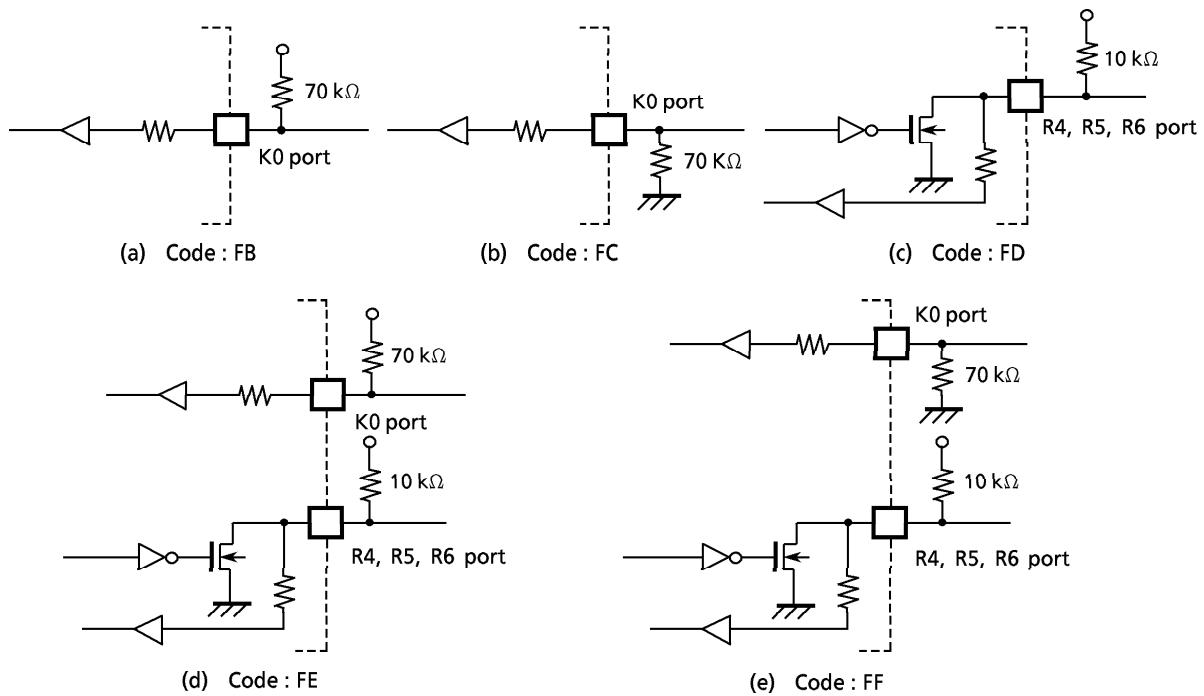
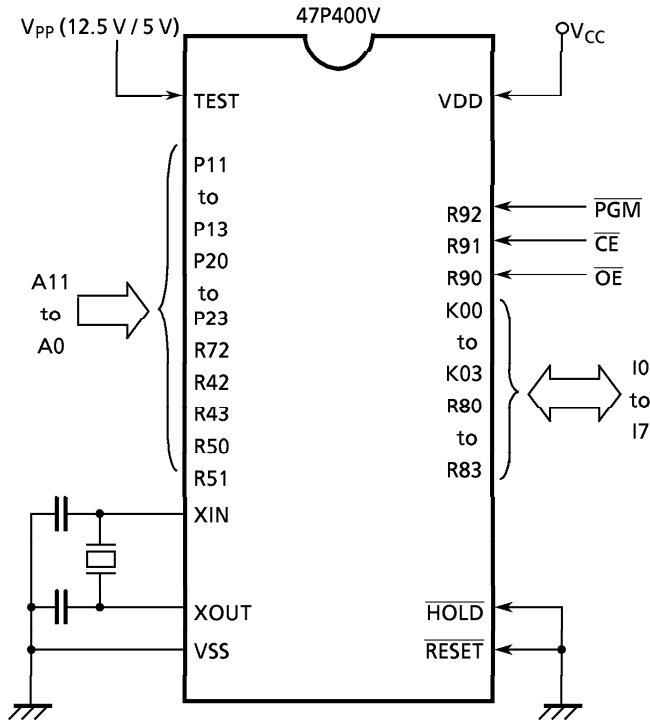

Figure 1-3. I/O code and external circuitry

1.2 PROM Mode

The PROM mode is set by setting the  $\overline{\text{RESET}}$ ,  $\overline{\text{HOLD}}$  pins to the "L" level. The PROM mode can be used as a general-purpose PROM writer for program writing and verification (A high-speed program mode is used set the ROM type the same as for the TMM2764AD).



For more information on pins refer to the section on pin function.

**Note.** When writing a program, set a ROM type to 2764AD (programming voltage : 12.5V). Since the 47P400B has 4096 x 8 bit internal PROM (000 to FFFH), set a stop address of a PROM writer to "FFFH", or store the same data to the latter half addresses 1000 to 1FFFH.

Figure 1-4. Setting for PROM mode

1.2.1 High Speed Programming Mode

The device is set up in the high speed programming mode when the programming voltage (12.5 V) is applied to the Vpp terminal with Vcc = 6 V and  $\overline{\text{PGM}} = V_{IH4}$ . The programming is achieved by applying a Single TTL low level 1 msec, pulse the  $\overline{\text{PGM}}$  input after addresses and data are stable. Then the programmed data is verified by using program Verify Mode. If the programmed data is not correct, another program pulse of 1 msec is applied and then programmed data is verified. This should be repeated until the program operates correctly (max. 25 times). After correctly programming the selected address, one additional program pulse with pulse width 3 times that needed for programming is applied. When programming has been completed, the data in all addresses should be verified with Vcc = Vpp = 5 V.

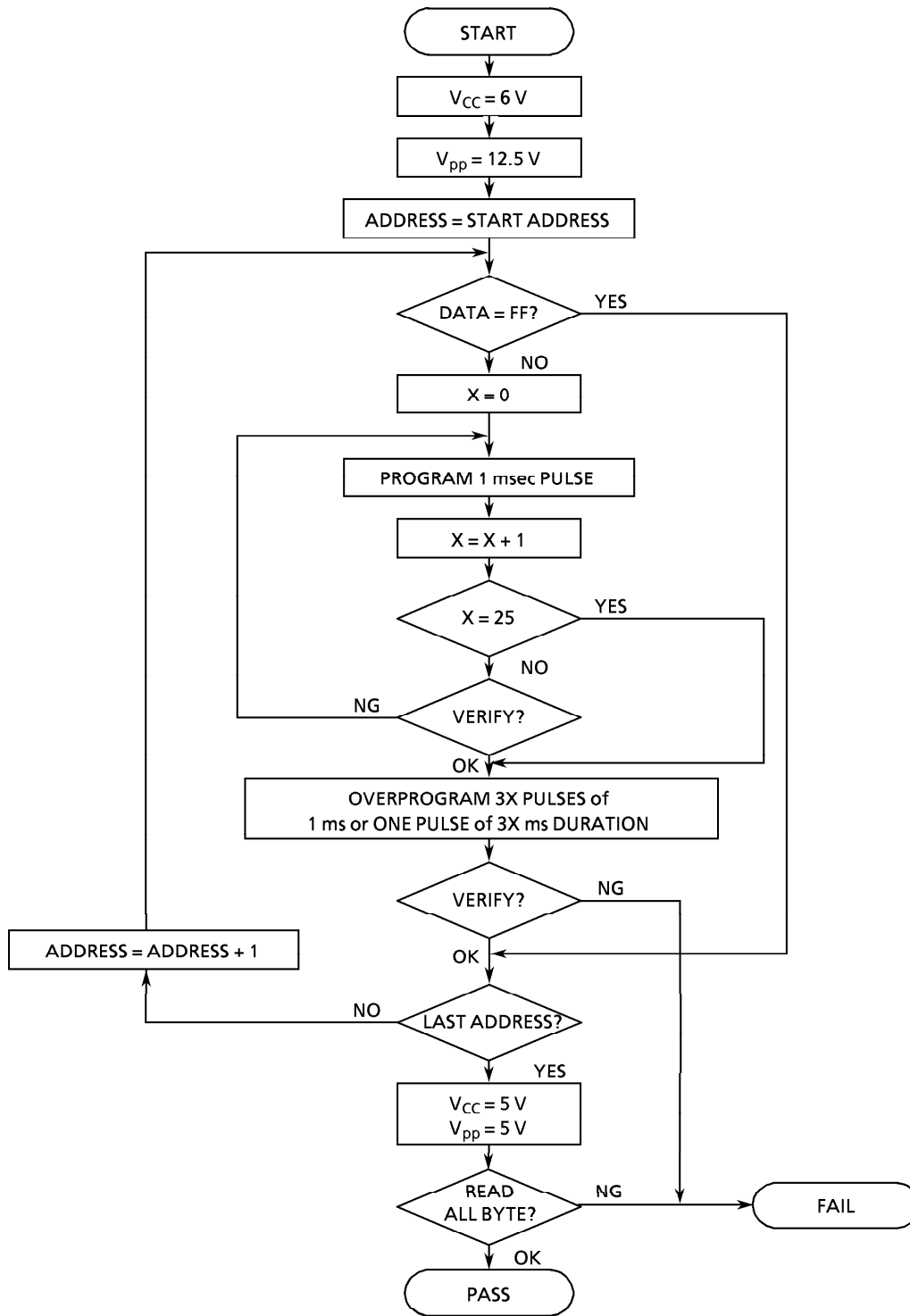

Figure1-5. Flow Chart

## ELECTRICAL CHARACTERISTICS

## ABSOLUTE MAXIMUM RATINGS

(V<sub>SS</sub> = 0 V)

PARAMETER	SYMBOL	PINS	RATINGS	UNIT
Supply Voltage	V <sub>DD</sub>		- 0.3 to 7	V
Program Voltage	V <sub>PP</sub>	TEST/VPP pin	- 0.3 to 13.0	V
Input Voltage	V <sub>IN</sub>		- 0.3 to V <sub>DD</sub> + 0.3	V
Output Voltage	V <sub>OUT1</sub>	Except sink open drain pin, but include R8	- 0.3 to V <sub>DD</sub> + 0.3	V
	V <sub>OUT2</sub>	Sink open drain pin except R8	- 0.3 to 10	
Output Current (per 1 pin)	I <sub>OUT1</sub>	P1, P2	30	mA
	I <sub>OUT2</sub>	R4 to R9	3.2	
Output Current (total all pin)	ΣI <sub>OUT1</sub>	P1, P2	120	mA
Power Dissipation [Topr = 70°C]	PD		600	mW
Soldering Temperature (time)	T <sub>sld</sub>		260 (10 s)	°C
Storage Temperature	T <sub>stg</sub>		- 55 to 125	°C
Operating Temperature	Topr		- 30 to 70	°C

## RECOMMENDED OPERATING CONDITIONS

(V<sub>SS</sub> = 0 V, T<sub>opr</sub> = - 30 to 70 °C)

PARAMETER	SYMBOL	PINS	CONDITIONS	Min.	Max.	UNIT
Supply Voltage	V <sub>DD</sub>		In the Normal mode	2.7	6.0	V
			In the HOLD mode	2.0		
Input High Voltage	V <sub>IH1</sub>	Except hysteresis input	V <sub>DD</sub> ≥ 4.5 V	V <sub>DD</sub> × 0.7	V <sub>DD</sub>	V
	V <sub>IH2</sub>	Hysteresis input		V <sub>DD</sub> × 0.75		
	V <sub>IH3</sub>		V <sub>DD</sub> < 4.5 V	V <sub>DD</sub> × 0.9		
Input Low Voltage	V <sub>IL1</sub>	Except hysteresis input	V <sub>DD</sub> ≥ 4.5 V	0	V <sub>DD</sub> × 0.3	V
	V <sub>IL2</sub>	Hysteresis input			V <sub>DD</sub> × 0.25	
	V <sub>IL3</sub>		V <sub>DD</sub> < 4.5 V		V <sub>DD</sub> × 0.1	
Clock Frequency	f <sub>c</sub>		V <sub>DD</sub> = 2.7 to 6.0 V	0.4	4.2	MHz

## D.C. CHARACTERISTICS

 $(V_{SS} = 0 \text{ V}, T_{opr} = -30 \text{ to } 70 \text{ }^\circ\text{C})$ 

PARAMETER	SYMBOL	PINS	CONDITIONS	Min.	Typ.	Max.	UNIT
Hysteresis Voltage	$V_{HS}$	Hysteresis Input		—	0.7	—	v
Input Current	$I_{IN1}$	Port K0, TEST, RESET, HOLD	$V_{DD} = 5.5 \text{ V},$ $V_{IN} = 5.5 \text{ V} / 0 \text{ V}$	—	—	$\pm 2$	$\mu\text{A}$
	$I_{IN2}$	Port R (open drain)					
Input Low Current	$I_{IL}$	Port R (push-pull)	$V_{DD} = 5.5 \text{ V}, V_{IN} = 0.4 \text{ V}$	—	—	—2	mA
Input Resistance	$R_{IN2}$	RESET		100	220	450	$\text{k}\Omega$
Output Leakage Current	$I_{LO}$	Ports P, R (open drain)	$V_{DD} = 5.5 \text{ V}, V_{OUT} = 5.5 \text{ V}$	—	—	2	$\mu\text{A}$
Output High Voltage	$V_{OH}$	Port R (push-pull)	$V_{DD} = 4.5 \text{ V}, I_{OH} = -200 \mu\text{A}$	2.4	—	—	V
Output Low Voltage	$V_{OL2}$	Except XOUT, Port P	$V_{DD} = 4.5 \text{ V}, I_{OL} = 1.6 \text{ mA}$	—	—	0.4	V
Output Low Current	$I_{OL1}$	Port P	$V_{DD} = 4.5 \text{ V}, V_{OL} = 1.0 \text{ V}$	—	30	—	mA
Supply Current (in the Normal mode)	$I_{DD}$		$V_{DD} = 5.5 \text{ V } f_c = 4 \text{ MHz}$	—	2	4	mA
			$V_{DD} = 3.0 \text{ V } f_c = 4 \text{ MHz}$	—	1	2	mA
Supply Current (in the HOLD mode)	$I_{DDH}$		$V_{DD} = 5.5 \text{ V}$	—	0.5	10	$\mu\text{A}$

Note 1. Typ.values show those at  $T_{opr} = 25 \text{ }^\circ\text{C}$ ,  $V_{DD} = 5 \text{ V}$ .

Note 2. Input Current  $I_{IN1}$ : The current through resistor is not included, when the pull-up / pull-down resistor is contained.

Note 3. Supply Current:  $V_{IN} = 5.3 \text{ V} / 0.2 \text{ V}$  ( $V_{DD} = 5.5 \text{ V}$ ),  $2.8 / 0.2 \text{ v}$  ( $V_{DD} = 3.0 \text{ V}$ )



A.C. CHARACTERISTICS

( $V_{SS} = 0\text{ V}$ ,  $V_{DD} = 2.7\text{ to }6.0\text{ V}$ ,  $T_{opr} = -30\text{ to }70\text{ }^\circ\text{C}$ )

PARAMETER	SYMBOL	CONDITIONS	Min.	Typ.	Max.	UNIT
Instruction Cycle Time	$t_{cy}$		1.9	-	20	$\mu\text{s}$
High Level Clock Pulse Width	$t_{WCH}$	External clock mode	80	-	-	ns
Low Level Clock Pulse Width	$t_{WCL}$					
Shift Data Hold Time	$t_{SDH}$		$0.5t_{cy} - 300$	-	-	ns

Note. Shift Data Hold Time :

External circuit for  $\overline{\text{SCK}}$  pin and SO pin Serial port (completion of transmission)

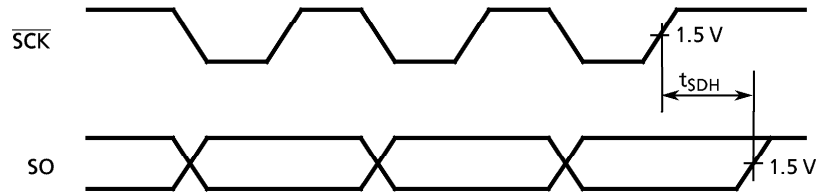
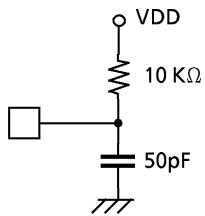

RECOMMENDED OSCILLATING CONDITIONS

( $V_{SS} = 0\text{ V}$ ,  $V_{DD} = 2.7\text{ to }6.0\text{ V}$ ,  $T_{opr} = -30\text{ to }70\text{ }^\circ\text{C}$ )

Recommended oscillating conditions of the 47P400V are equal to the 47C200B/400B's.

D.C./A.C. CHARACTERISTICS (PROM mode)

( $V_{SS} = 0\text{ V}$ )

(1) Read Operation

PARAMETER	SYMBOL	CONDITION	Min.	Typ.	Max.	UNIT
Output Level High Voltage	$V_{IH4}$		$V_{CC} \times 0.7$	-	$V_{CC}$	V
Output Level Low Voltage	$V_{IL4}$		0	-	$V_{CC} \times 0.3$	V
Supply Voltage	$V_{CC}$		4.75	-	6.0	V
Programming Voltage	$V_{PP}$					
Address Access Time	$t_{ACC}$	$V_{CC} = 5.0 \pm 0.25\text{ V}$	-	-	350	ns

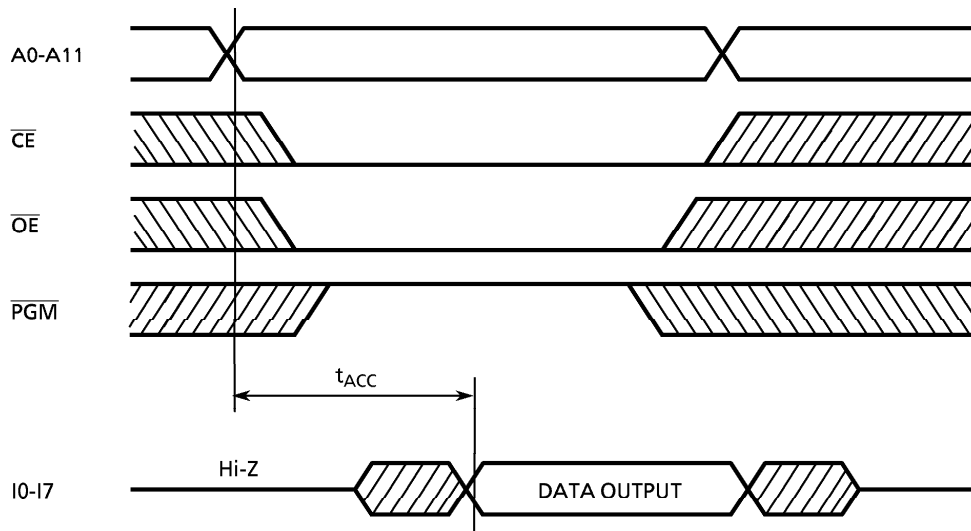

(2) High Speed Programming Operation

PARAMETER	SYMBOL	CONDITION	Min.	Typ.	Max.	UNIT
Input High Voltage	$V_{IH4}$		$V_{CC} \times 0.7$	–	$V_{CC}$	V
Input Low Voltage	$V_{IL4}$		0	–	$V_{CC} \times 0.3$	V
Supply Voltage	$V_{CC}$		4.75	–	6.0	V
$V_{PP}$ Power Supply Voltage	$V_{PP}$		12.0	12.5	13.0	V
Programming Pulse Width	$t_{PW}$	$V_{CC} = 6.0 \pm 0.25 V$	0.95	1.0	1.05	ms

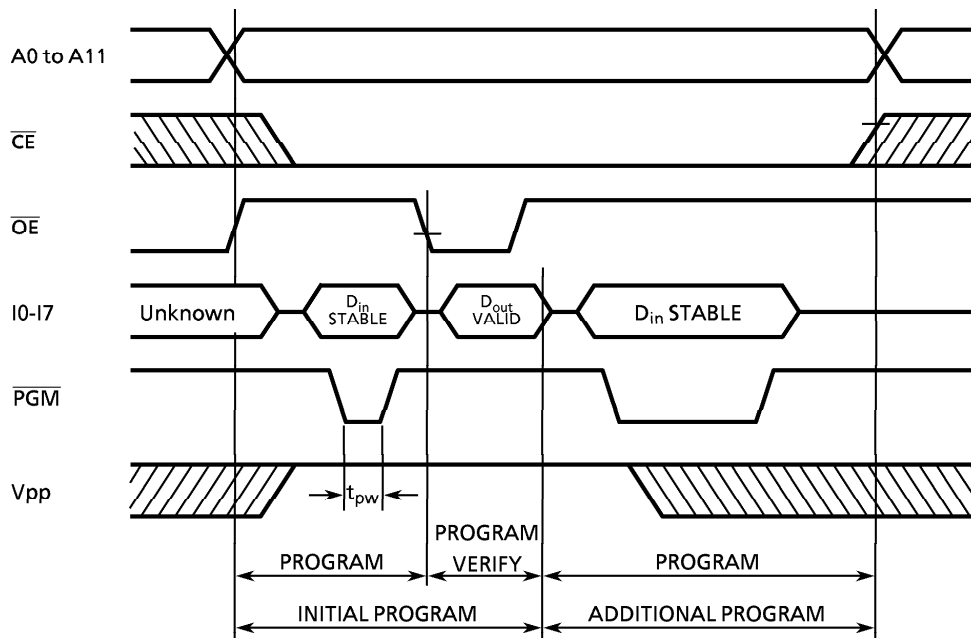

TYPICAL CHARACTERISTICS

