

## BICMOS POWER FACTOR PREREGULATOR

### FEATURES

- Controls Boost Preregulator to Near-Unity Power Factor
- Limits Line Distortion
- World Wide Line Operation
- Over-Voltage Protection
- Accurate Power Limiting
- Average Current Mode Control
- Improved Noise Immunity
- Improved Feed-Forward Line Regulation
- Leading Edge Modulation
- 150- $\mu$ A Typical Start-Up Current
- Low-Power BiCMOS Operation
- 12-V to 17-V Operation

### DESCRIPTION

The UCC3817A and the UCC3818A family provides all the functions necessary for active power factor corrected preregulators. The controller achieves near unity power factor by shaping the ac input line current waveform to correspond to that of the ac input line voltage. Average current mode control maintains stable, low distortion sinusoidal line current.

Designed in Texas Instrument's BiCMOS process, the UCC3817A/UCC3818A offers new features such as lower start-up current, lower power dissipation, overvoltage protection, a shunt UVLO detect circuitry, a leading-edge modulation technique to reduce ripple current in the bulk capacitor and an improved, low-offset ( $\pm 2$  mV) current amplifier to reduce distortion at light load conditions.

### BLOCK DIAGRAM

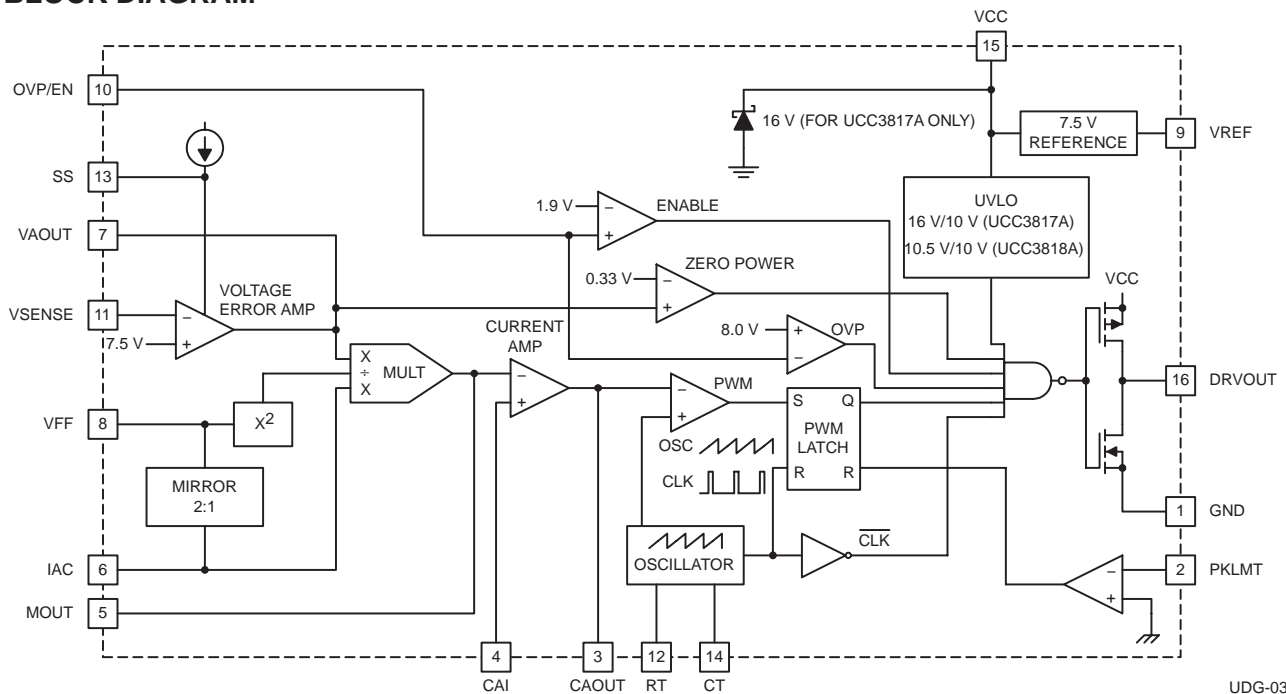

UDG-03122



Please be aware that an important notice concerning availability, standard warranty, and use in critical applications of Texas Instruments semiconductor products and disclaimers thereto appears at the end of this data sheet.

# UCC2817A, UCC2818A UCC3817A, UCC3818A

SLUS577A – SEPTEMBER, 2003 – REVISED OCTOBER 2003

## DESCRIPTION (CONTINUED)

The UCC3817A/18A family of PFC Controllers is directly pin for pin compatible with the UCC3817/18 family of devices. Only the output stage of UCC3817A family has been modified to allow use of a smaller external gate drive resistor values. For some power supply designs where an adequately high enough gate drive resistor can not be used, the UCC3817A/18A family offers a more robust output stage at the cost of increasing the internal gate resistances. The gate drive of the UC3817A/18A family however remains strong at  $\pm 1.2$  A of peak current capability.

UCC3817A offers an on-chip shunt regulator with low start-up current, suitable for applications utilizing a bootstrap supply. UCC3818A is intended for applications with a fixed supply (VCC). Both devices are available in the 16-pin D, N and PW packages.

## PIN CONNECTION DIAGRAM

D, N, AND PW PACKAGES  
(TOP VIEW)

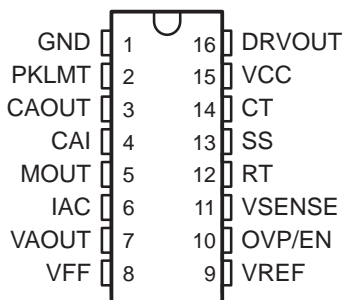

AVAILABLE OPTIONS TABLE

| T <sub>A</sub> = T <sub>J</sub> | PACKAGE DEVICES                 |                             |                           |                             |                                   |                             |
|---------------------------------|---------------------------------|-----------------------------|---------------------------|-----------------------------|-----------------------------------|-----------------------------|
|                                 | SOIC (D) PACKAGE <sup>(1)</sup> |                             | PDIP (N) PACKAGE          |                             | TSSOP (PW) PACKAGE <sup>(1)</sup> |                             |
|                                 | Turn-on Threshold<br>16 V       | Turn-on Threshold<br>10.2 V | Turn-on Threshold<br>16 V | Turn-on Threshold<br>10.2 V | Turn-on Threshold<br>16 V         | Turn-on Threshold<br>10.2 V |
| -40°C to 85°C                   | UCC2817AD                       | UCC2818AD                   | UCC2817AN                 | UCC2818AN                   | UCC2817APW                        | UCC2818APW                  |
| 0°C to 70°C                     | UCC3817AD                       | UCC3818AD                   | UCC3817AN                 | UCC3818AN                   | UCC3817APW                        | UCC3818APW                  |

NOTES: (1) The D and PW packages are available taped and reeled. Add R suffix to the device type (e.g. UCC3817ADR) to order quantities of 2,500 devices per reel (D package) and 2,000 devices per reel (for PW package). Bulk quantities are 40 units (D package) and 90 units (PW package) per tube.

THERMAL RESISTANCE TABLE

| PACKAGE       | $\theta_{jc}$ (°C/W) | $\theta_{ja}$ (°C/W)      |
|---------------|----------------------|---------------------------|
| SOIC-16 (D)   | 22                   | 40 to 70 <sup>(1)</sup>   |
| PDIP-16 (N)   | 12                   | 25 to 50 <sup>(1)</sup>   |
| TSSOP-16 (PW) | 14 <sup>(2)</sup>    | 123 to 147 <sup>(2)</sup> |

NOTES: (1) Specified  $\theta_{ja}$  (junction to ambient) is for devices mounted to 5-inch<sup>2</sup> FR4 PC board with one ounce copper where noted. When resistance range is given, lower values are for 5 inch<sup>2</sup> aluminum PC board. Test PWB was 0.062 inch thick and typically used 0.635-mm trace widths for power packages and 1.3-mm trace widths for non-power packages with a 100-mil x 100-mil probe land area at the end of each trace.

(2) Modeled data. If value range given for  $\theta_{ja}$ , lower value is for 3x3 inch. 1 oz internal copper ground plane, higher value is for 1x1-inch. ground plane. All model data assumes only one trace for each non-fused lead.

## ABSOLUTE MAXIMUM RATINGS

over operating free-air temperature (unless otherwise noted)†

|  | UCCx81xA   | UNIT |
|--|------------|------|
| Supply voltage VCC   | 18         | V    |
| Supply current ICC   | 20         | mA   |
| Gate drive current, continuous                             | 0.2        | A    |
| Gate drive current   | 1.2        |      |
| Input voltage, CAI, MOUT, SS                               | 8          | V    |
| Input voltage, PKLMT                                       | 5          |      |
| Input voltage, VSENSE, OVP/EN                              | 10         |      |
| Input current, RT, IAC, PKLMT                              | 10         | mA   |
| Input current, VCC (no switching)                          | 20         |      |
| Maximum negative voltage, DRVOUT, PKLMT, MOUT              | -0.5       | V    |
| Power dissipation  | 1          | W    |
| Junction temperature, T <sub>J</sub>                       | -55 to 150 | °C   |
| Storage temperature, T <sub>stg</sub>                      | -65 to 150 |      |
| Lead temperature, T <sub>sol</sub> (soldering, 10 seconds) | 300        |      |
| Power dissipation  | 1          |      |

† Stresses beyond those listed under “absolute maximum ratings” may cause permanent damage to the device. These are stress ratings only, and functional operation of the device at these or any other conditions beyond those indicated under recommended operating conditions is not implied. Exposure to absolute-maximum-rated conditions for extended periods may affect device reliability.

## ELECTRICAL CHARACTERISTICS

T<sub>A</sub> = 0°C to 70°C for the UCC3817A and T<sub>A</sub> = -40°C to 85°C for the UCC2817A, T<sub>A</sub> = T<sub>J</sub>, VCC = 12 V, R<sub>T</sub> = 22 kΩ, C<sub>T</sub> = 270 pF, (unless otherwise noted)

| PARAMETER                        | TEST CONDITIONS                       | MIN   | TYP  | MAX   | UNITS |
|----------------------------------|---------------------------------------|-------|------|-------|-------|
| <b>Supply Current Section</b>    |                                       |       |      |       |       |
| Supply current, off              | VCC = (VCC turn-on threshold - 0.3 V) |       | 150  | 300   | μA    |
| Supply current, on               | VCC = 12 V, No load on DRVOUT         | 2     | 4    | 6     | mA    |
| <b>UVLO Section</b>              |                                       |       |      |       |       |
| VCC turn-on threshold (UCCx817)  |                                       | 15.4  | 16   | 16.6  | V     |
| VCC turn-off threshold (UCCx817) |                                       | 9.4   | 9.7  |       |       |
| UVLO hysteresis (UCCx817)        |                                       | 5.8   | 6.3  |       |       |
| Maximum shunt voltage (UCCx817)  | I <sub>VCC</sub> = 10 mA              | 15.4  | 17   | 17.5  |       |
| VCC turn-on threshold (UCCx818)  |                                       | 9.7   | 10.2 | 10.8  |       |
| VCC turn-off threshold (UCCx818) |                                       | 9.4   | 9.7  |       |       |
| UVLO hysteresis (UCCx818)        |                                       | 0.3   | 0.5  |       |       |
| <b>Voltage Amplifier Section</b> |                                       |       |      |       |       |
| Input voltage                    | T <sub>A</sub> = 0°C to 70°C          | 7.387 | 7.5  | 7.613 | V     |
|                                  | T <sub>A</sub> = -40°C to 85°C        | 7.369 | 7.5  | 7.631 |       |
| VSENSE bias current              | VSENSE = VREF, VAOUT = 2.5 V          |       | 50   | 200   | nA    |
| Open loop gain                   | VAOUT = 2 V to 5 V                    | 50    | 90   |       | dB    |
| High-level output voltage        | I <sub>L</sub> = -150 μA              | 5.3   | 5.5  | 5.6   | V     |
| Low-level output voltage         | I <sub>L</sub> = 150 μA               | 0     | 50   | 150   | mV    |

# UCC2817A, UCC2818A UCC3817A, UCC3818A

SLUS577A – SEPTEMBER, 2003 – REVISED OCTOBER 2003

## ELECTRICAL CHARACTERISTICS

$T_A = 0^\circ\text{C}$  to  $70^\circ\text{C}$  for the UCC3817A and  $T_A = -40^\circ\text{C}$  to  $85^\circ\text{C}$  for the UCC2817A,  $T_A = T_J$ ,  $V_{CC} = 12\text{ V}$ ,  $R_T = 22\text{ k}\Omega$ ,  $C_T = 270\text{ pF}$ , (unless otherwise noted)

| PARAMETER   | TEST CONDITIONS  | MIN           | TYP           | MAX           | UNITS |
|---|--|---------------|---------------|---------------|-------|
| <b>Over Voltage Protection and Enable Section</b> |  |               |               |               |       |
| Over voltage reference                            |  | VREF<br>+0.48 | VREF<br>+0.50 | VREF<br>+0.52 | V     |
| Hysteresis  |  | 300           | 500           | 600           | mV    |
| Enable threshold                                  |  | 1.7           | 1.9           | 2.1           | V     |
| Enable hysteresis                                 |  | 0.1           | 0.2           | 0.3           |       |
| <b>Current Amplifier Section</b>                  |  |               |               |               |       |
| Input offset voltage                              | $V_{CM} = 0\text{ V}$ ,<br>$V_{CAOUT} = 3\text{ V}$                  | -3.5          | 0             | 2.5           | mV    |
| Input bias current                                | $V_{CM} = 0\text{ V}$ ,<br>$V_{CAOUT} = 3\text{ V}$                  |               | -50           | -100          | nA    |
| Input offset current                              | $V_{CM} = 0\text{ V}$ ,<br>$V_{CAOUT} = 3\text{ V}$                  |               | 25            | 100           |       |
| Open loop gain                                    | $V_{CM} = 0\text{ V}$ ,<br>$V_{CAOUT} = 2\text{ V to } 5\text{ V}$   | 90            |               |               | dB    |
| Common-mode rejection ratio                       | $V_{CM} = 0\text{ V to } 1.5\text{ V}$ ,<br>$V_{CAOUT} = 3\text{ V}$ | 60            | 80            |               |       |
| High-level output voltage                         | $I_L = -120\text{ }\mu\text{A}$                                      | 5.6           | 6.5           | 6.8           | V     |
| Low-level output voltage                          | $I_L = 1\text{ mA}$  | 0.1           | 0.2           | 0.5           |       |
| Gain bandwidth product                            | (1)  |               | 2.5           |               | MHz   |
| <b>Voltage Reference Section</b>                  |  |               |               |               |       |
| Input voltage                                     | $T_A = 0^\circ\text{C to } 70^\circ\text{C}$                         | 7.387         | 7.5           | 7.613         | V     |
|   | $T_A = -40^\circ\text{C to } 85^\circ\text{C}$                       | 7.369         | 7.5           | 7.631         |       |
| Load regulation                                   | $I_{REF} = 1\text{ mA to } 2\text{ mA}$                              | 0             |               | 10            | mV    |
| Line regulation                                   | $V_{CC} = 10.8\text{ V to } 15\text{ V}^{(2)}$                       | 0             |               | 10            |       |
| Short-circuit current                             | $V_{REF} = 0\text{ V}$   | -20           | -25           | -50           | mA    |
| <b>Oscillator Section</b>                         |  |               |               |               |       |
| Initial accuracy                                  | $T_A = 25^\circ\text{C}$   | 85            | 100           | 115           | kHz   |
| Voltage stability                                 | $V_{CC} = 10.8\text{ V to } 15\text{ V}$                             | -1            |               | 1             | %     |
| Total variation                                   | Line, temp   | 80            |               | 120           | kHz   |
| Ramp peak voltage                                 |  | 4.5           | 5             | 5.5           | V     |
| Ramp amplitude voltage<br>(peak to peak)          |  | 3.5           | 4             | 4.5           |       |
| <b>Peak Current Limit Section</b>                 |  |               |               |               |       |
| PKLMT reference voltage                           |  | -15           |               | 15            | mV    |
| PKLMT propagation delay                           |  | 150           | 350           | 500           | ns    |

NOTES: 1. Ensured by design, not production tested.  
2. Reference variation for  $V_{CC} < 10.8\text{ V}$  is shown in Figure 8.

**ELECTRICAL CHARACTERISTICS**

$T_A = 0^\circ\text{C}$  to  $70^\circ\text{C}$  for the UCC3817A and  $T_A = -40^\circ\text{C}$  to  $85^\circ\text{C}$  for the UCC2817A,  $T_A = T_J$ ,  $V_{CC} = 12\text{ V}$ ,  $R_T = 22\text{ k}\Omega$ ,  $C_T = 270\text{ pF}$ , (unless otherwise noted)

| PARAMETER   | TEST CONDITIONS  | MIN  | TYP  | MAX  | UNITS         |
|---|--|------|------|------|---------------|
| <b>Multiplier Section</b>   |  |      |      |      |               |
| $I_{MOUT}$ , high line, low power output current, ( $0^\circ\text{C}$ to $85^\circ\text{C}$ )   | $I_{AC} = 500\ \mu\text{A}$ , $V_{FF} = 4.7\text{ V}$ , $VA_{OUT} = 1.25\text{ V}$       | 0    | -6   | -20  | $\mu\text{A}$ |
| $I_{MOUT}$ , high line, low power output current, ( $-40^\circ\text{C}$ to $85^\circ\text{C}$ ) | $I_{AC} = 500\ \mu\text{A}$ , $V_{FF} = 4.7\text{ V}$ , $VA_{OUT} = 1.25\text{ V}$       | 0    | -6   | -23  |               |
| $I_{MOUT}$ , high line, high power output current   | $I_{AC} = 500\ \mu\text{A}$ , $V_{FF} = 4.7\text{ V}$ , $VA_{OUT} = 5\text{ V}$          | -70  | -90  | -105 |               |
| $I_{MOUT}$ , low line, low power output current   | $I_{AC} = 150\ \mu\text{A}$ , $V_{FF} = 1.4\text{ V}$ , $VA_{OUT} = 1.25\text{ V}$       | -10  | -19  | -50  |               |
| $I_{MOUT}$ , low line, high power output current  | $I_{AC} = 150\ \mu\text{A}$ , $V_{FF} = 1.4\text{ V}$ , $VA_{OUT} = 5\text{ V}$          | -268 | -300 | -345 |               |
| $I_{MOUT}$ , IAC limited output current   | $I_{AC} = 150\ \mu\text{A}$ , $V_{FF} = 1.3\text{ V}$ , $VA_{OUT} = 5\text{ V}$          | -250 | -300 | -400 |               |
| Gain constant (K)   | $I_{AC} = 300\ \mu\text{A}$ , $V_{FF} = 3\text{ V}$ , $VA_{OUT} = 2.5\text{ V}$          | 0.5  | 1    | 1.5  | 1/V           |
| $I_{MOUT}$ , zero current   | $I_{AC} = 150\ \mu\text{A}$ , $V_{FF} = 1.4\text{ V}$ , $VA_{OUT} = 0.25\text{ V}$       |      | 0    | -2   | $\mu\text{A}$ |
|   | $I_{AC} = 500\ \mu\text{A}$ , $V_{FF} = 4.7\text{ V}$ , $VA_{OUT} = 0.25\text{ V}$       |      | 0    | -2   |               |
| $I_{MOUT}$ , zero current, ( $0^\circ\text{C}$ to $85^\circ\text{C}$ )                          | $I_{AC} = 500\ \mu\text{A}$ , $V_{FF} = 4.7\text{ V}$ , $VA_{OUT} = 0.5\text{ V}$        |      | 0    | -3   |               |
| $I_{MOUT}$ , zero current, ( $-40^\circ\text{C}$ to $85^\circ\text{C}$ )                        | $I_{AC} = 500\ \mu\text{A}$ , $V_{FF} = 4.7\text{ V}$ , $VA_{OUT} = 0.5\text{ V}$        |      | 0    | -3.5 |               |
| Power limit ( $I_{MOUT} \times V_{FF}$ )  | $I_{AC} = 150\ \mu\text{A}$ , $V_{FF} = 1.4\text{ V}$ , $VA_{OUT} = 5\text{ V}$          | -375 | -420 | -485 | $\mu\text{W}$ |
| <b>Feed-Forward Section</b>   |  |      |      |      |               |
| VFF output current  | $I_{AC} = 300\ \mu\text{A}$  | -140 | -150 | -160 | $\mu\text{A}$ |
| <b>Soft Start Section</b>   |  |      |      |      |               |
| SS charge current   |  | -6   | -10  | -16  | $\mu\text{A}$ |
| <b>Gate Driver Section</b>  |  |      |      |      |               |
| Pullup resistance   | $I_O = -100\text{ mA}$ to $-200\text{ mA}$   |      | 9    | 12   | $\Omega$      |
| Pulldown resistance   | $I_O = 100\text{ mA}$  |      | 4    | 10   |               |
| Output rise time  | $C_L = 1\text{ nF}$ , $R_L = 10\ \Omega$ , $V_{DRVOUT} = 0.7\text{ V}$ to $9.0\text{ V}$ |      | 25   | 50   | ns            |
| Output fall time  | $C_L = 1\text{ nF}$ , $R_L = 10\ \Omega$ , $V_{DRVOUT} = 9.0\text{ V}$ to $0.7\text{ V}$ |      | 10   | 50   |               |
| Maximum duty cycle  |  | 93%  | 95%  | 99%  |               |
| Minimum controlled duty cycle   | At 100 kHz   |      |      | 2%   |               |
| <b>Zero Power Section</b>   |  |      |      |      |               |
| Zero power comparator threshold   | Measured on $VA_{OUT}$   | 0.20 | 0.33 | 0.50 | V             |

**PIN ASSIGNMENTS**

| TERMINAL |     | I/O | DESCRIPTION   |
|----------|-----|-----|---|
| NAME     | NO. |     |   |
| CAI      | 4   | I   | Current amplifier noninverting input                    |
| CAOUT    | 3   | O   | Current amplifier output                                |
| CT       | 14  | I   | Oscillator timing capacitor                             |
| DRVOUT   | 16  | O   | Gate drive  |
| GND      | 1   | –   | Ground  |
| IAC      | 6   | I   | Current proportional to input voltage                   |
| MOUT     | 5   | I/O | Multiplier output and current amplifier inverting input |
| OVP/EN   | 10  | I   | Over-voltage/enable                                     |
| PKLMT    | 2   | I   | PFC peak current limit                                  |
| RT       | 12  | I   | Oscillator charging current                             |
| SS       | 13  | I   | Soft-start  |
| VAOUT    | 7   | O   | Voltage amplifier output                                |
| VCC      | 15  | I   | Positive supply voltage                                 |
| VFF      | 8   | I   | Feed-forward voltage                                    |
| VSENSE   | 11  | I   | Voltage amplifier inverting input                       |
| VREF     | 9   | O   | Voltage reference output                                |

**Pin Descriptions**

**CAI:** Place a resistor between this pin and the GND side of current sense resistor. This input and the inverting input (MOUT) remain functional down to and below GND.

**CAOUT:** This is the output of a wide bandwidth operational amplifier that senses line current and commands the PFC pulse-width modulator (PWM) to force the correct duty cycle. Compensation components are placed between CAOUT and MOUT.

**CT:** A capacitor from CT to GND sets the PWM oscillator frequency according to:

$$f \approx \left( \frac{0.6}{RT \times CT} \right)$$

The lead from the oscillator timing capacitor to GND should be as short and direct as possible.

**DRVOUT:** The output drive for the boost switch is a totem-pole MOSFET gate driver on DRVOUT. To avoid the excessive overshoot of the DRVOUT while driving a capacitive load, a series gate current-limiting/damping resistor is recommended to prevent interaction between the gate impedance and the output driver. The value of the series gate resistor is based on the pulldown resistance ( $R_{pull\down}$  which is 4  $\Omega$  typical), the maximum VCC voltage (VCC), and the required maximum gate drive current ( $I_{MAX}$ ). Using the equation below, a series gate resistance of resistance 11  $\Omega$  would be required for a maximum VCC voltage of 18 V and for 1.2 A of maximum sink current. The source current will be limited to approximately 900 mA (based on the  $R_{pull\up}$  of 9- $\Omega$  typical).

$$R_{GATE} = \frac{VCC - (I_{MAX} \times R_{pull\down})}{I_{MAX}}$$

**GND:** All voltages measured with respect to ground. VCC and REF should be bypassed directly to GND with a 0.1- $\mu$ F or larger ceramic capacitor.

## Pin Descriptions (cont.)

**IAC:** This input to the analog multiplier is a current proportional to instantaneous line voltage. The multiplier is tailored for very low distortion from this current input ( $I_{IAC}$ ) to multiplier output. The recommended maximum  $I_{IAC}$  is 500  $\mu$ A.

**MOUT:** The output of the analog multiplier and the inverting input of the current amplifier are connected together at MOUT. As the multiplier output is a current, this is a high-impedance input so the amplifier can be configured as a differential amplifier. This configuration improves noise immunity and allows for the leading-edge modulation operation. The multiplier output current is limited to  $(2 \times I_{IAC})$ . The multiplier output current is given by the equation:

$$I_{MOUT} = \frac{I_{IAC} \times (V_{VAOUT} - 1)}{V_{VFF}^2 \times K}$$

where  $K = \frac{1}{V}$  is the multiplier gain constant.

**OVP/EN:** A window comparator input that disables the output driver if the boost output voltage is a programmed level above the nominal or disables both the PFC output driver and resets SS if pulled below 1.9 V (typ).

**PKLMT:** The threshold for peak limit is 0 V. Use a resistor divider from the negative side of the current sense resistor to VREF to level shift this signal to a voltage level defined by the value of the sense resistor and the peak current limit. Peak current limit is reached when PKLMT voltage falls below 0 V.

**RT:** A resistor from RT to GND is used to program oscillator charging current. A resistor between 10 k $\Omega$  and 100 k $\Omega$  is recommended. Nominal voltage on this pin is 3 V.

**SS:**  $V_{SS}$  is discharged for  $V_{VCC}$  low conditions. When enabled, SS charges an external capacitor with a current source. This voltage is used as the voltage error signal during start-up, enabling the PWM duty cycle to increase slowly. In the event of a  $V_{VCC}$  dropout, the OVP/EN is forced below 1.9 V (typ), SS quickly discharges to disable the PWM.

Note: In an open-loop test circuit, grounding the SS pin does not ensure 0% duty cycle. Please see the application section for details.

**VAOUT:** This is the output of the operational amplifier that regulates output voltage. The voltage amplifier output is internally limited to approximately 5.5 V to prevent overshoot.

**VCC:** Connect to a stable source of at least 20 mA between 10 V and 17 V for normal operation. Bypass VCC directly to GND to absorb supply current spikes required to charge external MOSFET gate capacitances. To prevent inadequate gate drive signals, the output devices are inhibited unless  $V_{VCC}$  exceeds the upper under-voltage lockout voltage threshold and remains above the lower threshold.

**VFF:** The RMS voltage signal generated at this pin by mirroring 1/2 of the  $I_{IAC}$  into a single pole external filter. At low line, the VFF voltage should be 1.4 V.

**VSENSE:** This is normally connected to a compensation network and to the boost converter output through a divider network.

**VREF:** VREF is the output of an accurate 7.5-V voltage reference. This output is capable of delivering 20 mA to peripheral circuitry and is internally short-circuit current limited. VREF is disabled and remains at 0 V when  $V_{VCC}$  is below the UVLO threshold. Bypass VREF to GND with a 0.1- $\mu$ F or larger ceramic capacitor for best stability. Please refer to Figures 8 and 9 for VREF line and load regulation characteristics.

**APPLICATION INFORMATION**

The UCC3817A is a BiCMOS average current mode boost controller for high power factor, high efficiency preregulator power supplies. Figure 1 shows the UCC3817A in a 250-W PFC preregulator circuit. Off-line switching power converters normally have an input current that is not sinusoidal. The input current waveform has a high harmonic content because current is drawn in pulses at the peaks of the input voltage waveform. An active power factor correction circuit programs the input current to follow the line voltage, forcing the converter to look like a resistive load to the line. A resistive load has 0° phase displacement between the current and voltage waveforms. Power factor can be defined in terms of the phase angle between two sinusoidal waveforms of the same frequency:

$$PF = \cos \Theta \tag{1}$$

Therefore, a purely resistive load would have a power factor of 1. In practice, power factors of 0.999 with THD (total harmonic distortion) of less than 3% are possible with a well-designed circuit. Following guidelines are provided to design PFC boost converters using the UCC3817A.

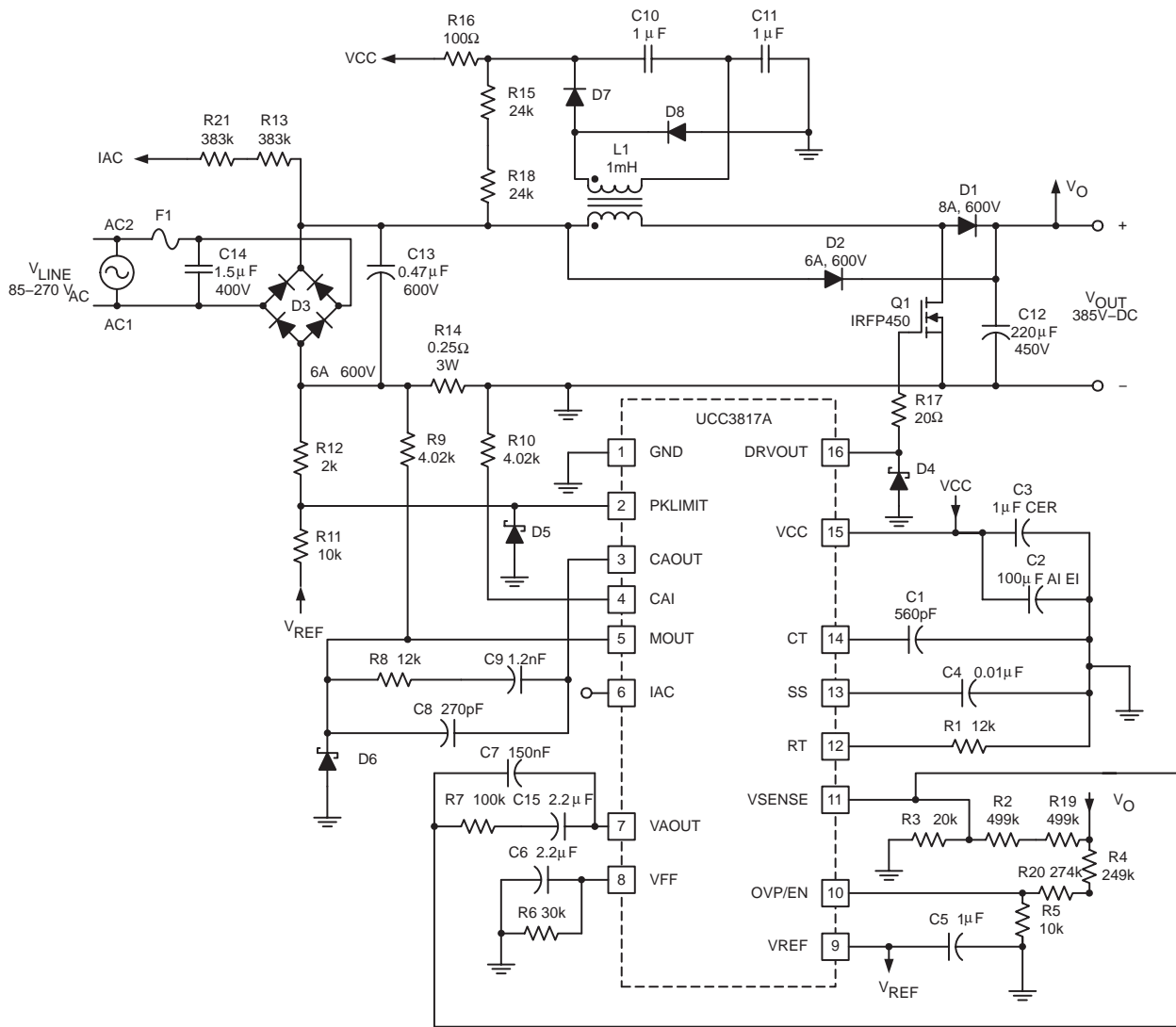

UDG-98183

**Figure 1. Typical Application Circuit**



## APPLICATION INFORMATION

### Power Stage

**L<sub>BOOST</sub>** : The boost inductor value is determined by:

$$L_{\text{BOOST}} = \frac{(V_{\text{IN}(\text{min})} \times D)}{(\Delta I \times f_{\text{S}})} \quad (2)$$

where D is the duty cycle,  $\Delta I$  is the inductor ripple current and  $f_{\text{S}}$  is the switching frequency. For the example circuit a switching frequency of 100 kHz, a ripple current of 875 mA, a maximum duty cycle of 0.688 and a minimum input voltage of 85 V<sub>RMS</sub> gives us a boost inductor value of about 1 mH. The values used in this equation are at the peak of low line, where the inductor current and its ripple are at a maximum.

**C<sub>OUT</sub>** : Two main criteria, the capacitance and the voltage rating, dictate the selection of the output capacitor. The value of capacitance is determined by the holdup time required for supporting the load after input ac voltage is removed. Holdup is the amount of time that the output stays in regulation after the input has been removed. For this circuit, the desired holdup time is approximately 16 ms. Expressing the capacitor value in terms of output power, output voltage, and holdup time gives the equation:

$$C_{\text{OUT}} = \frac{(2 \times P_{\text{OUT}} \times \Delta t)}{(V_{\text{OUT}}^2 - V_{\text{OUT}(\text{min})}^2)} \quad (3)$$

In practice, the calculated minimum capacitor value may be inadequate because output ripple voltage specifications limit the amount of allowable output capacitor ESR. Attaining a sufficiently low value of ESR often necessitates the use of a much larger capacitor value than calculated. The amount of output capacitor ESR allowed can be determined by dividing the maximum specified output ripple voltage by the inductor ripple current. In this design holdup time was the dominant determining factor and a 220- $\mu$ F, 450-V capacitor was chosen for the output voltage level of 385 VDC at 250 W.

## APPLICATION INFORMATION

**Power switch selection:** As in any power supply design, tradeoffs between performance, cost and size have to be made. When selecting a power switch, it can be useful to calculate the total power dissipation in the switch for several different devices at the switching frequencies being considered for the converter. Total power dissipation in the switch is the sum of switching loss and conduction loss. Switching losses are the combination of the gate charge loss,  $C_{OSS}$  loss and turnon and turnoff losses:

$$P_{GATE} = Q_{GATE} \times V_{GATE} \times f_S \quad (4)$$

$$P_{COSS} = \frac{1}{2} \times C_{OSS} \times V_{OFF}^2 \times f_S \quad (5)$$

$$P_{ON} + P_{OFF} = \frac{1}{2} \times V_{OFF} \times I_L \times (t_{ON} + t_{OFF}) \times f_S \quad (6)$$

where  $Q_{GATE}$  is the total gate charge,  $V_{GATE}$  is the gate drive voltage,  $f_S$  is the clock frequency,  $C_{OSS}$  is the drain source capacitance of the MOSFET,  $I_L$  is the peak inductor current,  $t_{ON}$  and  $t_{OFF}$  are the switching times (estimated using device parameters  $R_{GATE}$ ,  $Q_{GD}$  and  $V_{TH}$ ) and  $V_{OFF}$  is the voltage across the switch during the off time, in this case  $V_{OFF} = V_{OUT}$ .

Conduction loss is calculated as the product of the  $R_{DS(on)}$  of the switch (at the worst case junction temperature) and the square of RMS current:

$$P_{COND} = R_{DS(on)} \times K \times I_{RMS}^2 \quad (7)$$

where K is the temperature factor found in the manufacturer's  $R_{DS(on)}$  vs. junction temperature curves.

Calculating these losses and plotting against frequency gives a curve that enables the designer to determine either which manufacturer's device has the best performance at the desired switching frequency, or which switching frequency has the least total loss for a particular power switch. For this design example an IRFP450 HEXFET from International Rectifier was chosen because of its low  $R_{DS(on)}$  and its  $V_{DSS}$  rating. The IRFP450's  $R_{DS(on)}$  of 0.4  $\Omega$  and the maximum  $V_{DSS}$  of 500 V made it an ideal choice. An excellent review of this procedure can be found in the Unitrode Power Supply Design Seminar SEM1200, Topic 6, Design Review: 140 W, [Multiple Output High Density DC/DC Converter].

### Softstart

The softstart circuitry is used to prevent overshoot of the output voltage during start up. This is accomplished by bringing up the voltage amplifier's output ( $V_{VAOUT}$ ) slowly which allows for the PWM duty cycle to increase slowly. Please use the following equation to select a capacitor for the softstart pin.

In this example  $t_{DELAY}$  is equal to 7.5 ms, which would yield a  $C_{SS}$  of 10 nF.

$$C_{SS} = \frac{10 \mu A \times t_{DELAY}}{7.5 V} \quad (8)$$

In an open-loop test circuit, shorting the softstart pin to ground does not ensure 0% duty cycle. This is due to the current amplifiers input offset voltage, which could force the current amplifier output high or low depending on the polarity of the offset voltage. However, in the typical application there is sufficient amount of inrush and bias current to overcome the current amplifier's offset voltage.

## APPLICATION INFORMATION

### Multiplier

The output of the multiplier of the UCC3817A is a signal representing the desired input line current. It is an input to the current amplifier, which programs the current loop to control the input current to give high power factor operation. As such, the proper functioning of the multiplier is key to the success of the design. The inputs to the multiplier are VAOUT, the voltage amplifier error signal, I<sub>IAC</sub>, a representation of the input rectified ac line voltage, and an input voltage feedforward signal, V<sub>VFF</sub>. The output of the multiplier, I<sub>MOUT</sub>, can be expressed as:

$$I_{MOUT} = I_{IAC} \times \frac{(V_{VAOUT} - 1)}{K \times V_{VFF}^2} \quad (9)$$

where K is a constant typically equal to  $\frac{1}{V}$ .

The electrical characteristics table covers all the required operating conditions for designing with the multiplier. Additionally, curves in Figures 10, 11, and 12 provide typical multiplier characteristics over its entire operating range.

The I<sub>IAC</sub> signal is obtained through a high-value resistor connected between the rectified ac line and the IAC pin of the UCC3817A/18A. This resistor (R<sub>IAC</sub>) is sized to give the maximum I<sub>IAC</sub> current at high line. For the UCC3817A/18A the maximum I<sub>IAC</sub> current is about 500 μA. A higher current than this can drive the multiplier out of its linear range. A smaller current level is functional, but noise can become an issue, especially at low input line. Assuming a universal line operation of 85 V<sub>RMS</sub> to 265 V<sub>RMS</sub> gives a R<sub>IAC</sub> value of 750 kΩ. Because of voltage rating constraints of standard 1/4-W resistor, use a combination of lower value resistors connected in series to give the required resistance and distribute the high voltage amongst the resistors. For this design example two 383-kΩ resistors were used in series.

The current into the IAC pin is mirrored internally to the VFF pin where it is filtered to produce a voltage feed forward signal proportional to line voltage. The VFF voltage is used to keep the power stage gain constant; and to provide input power limiting. Please refer to Texas Instruments application note SLUA196 for detailed explanation on how the VFF pin provides power limiting. The following equation can be used to size the VFF resistor (R<sub>VFF</sub>) to provide power limiting where V<sub>IN(min)</sub> is the minimum RMS input voltage and R<sub>IAC</sub> is the total resistance connected between the IAC pin and the rectified line voltage.

$$R_{VFF} = \frac{1.4 V}{\frac{V_{IN(min)} \times 0.9}{2 \times R_{IAC}}} \approx 30 \text{ k}\Omega \quad (10)$$

### APPLICATION INFORMATION

Because the VFF voltage is generated from line voltage it needs to be adequately filtered to reduce total harmonic distortion caused by the 120 Hz rectified line voltage. Refer to Unitrode Power Supply Design Seminar, SEM-700 Topic 7, [Optimizing the Design of a High Power Factor Preregulator.] A single pole filter was adequate for this design. Assuming that an allocation of 1.5% total harmonic distortion from this input is allowed, and that the second harmonic ripple is 66% of the input ac line voltage, the amount of attenuation required by this filter is:

$$\frac{1.5\%}{66\%} = 0.022 \quad (11)$$

With a ripple frequency ( $f_R$ ) of 120 Hz and an attenuation of 0.022 requires that the pole of the filter ( $f_P$ ) be placed at:

$$f_P = 120 \text{ Hz} \times 0.022 \approx 2.6 \text{ Hz} \quad (12)$$

The following equation can be used to select the filter capacitor ( $C_{VFF}$ ) required to produce the desired low pass filter.

$$C_{VFF} = \frac{1}{2 \times \pi \times R_{VFF} \times f_P} \approx 2.2 \mu\text{F} \quad (13)$$

The  $R_{MOUT}$  resistor is sized to match the maximum current through the sense resistor to the maximum multiplier current. The maximum multiplier current, or  $I_{MOUT(max)}$ , can be determined by the equation:

$$I_{MOUT(max)} = \frac{I_{IAC@V_{IN(min)}} \times (V_{VAOUT(max)} - 1 \text{ V})}{K \times V_{VFF(min)}^2} \quad (14)$$

$I_{MOUT(max)}$  for this design is approximately 315  $\mu\text{A}$ . The  $R_{MOUT}$  resistor can then be determined by:

$$R_{MOUT} = \frac{V_{RSENSE}}{I_{MOUT(max)}} \quad (15)$$

In this example  $V_{RSENSE}$  was selected to give a dynamic operating range of 1.25 V, which gives an  $R_{MOUT}$  of roughly 3.91 k $\Omega$ .

**APPLICATION INFORMATION**

**Voltage Loop**

The second major source of harmonic distortion is the ripple on the output capacitor at the second harmonic of the line frequency. This ripple is fed back through the error amplifier and appears as a 3rd harmonic ripple at the input to the multiplier. The voltage loop must be compensated not just for stability but also to attenuate the contribution of this ripple to the total harmonic distortion of the system. (refer to Figure 2).

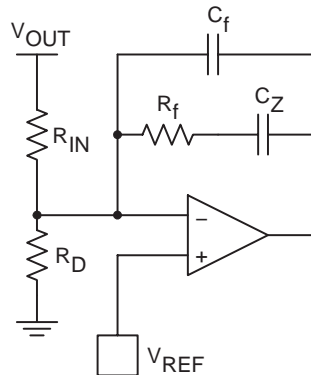

**Figure 2. Voltage Amplifier Configuration**

The gain of the voltage amplifier,  $G_{VA}$ , can be determined by first calculating the amount of ripple present on the output capacitor. The peak value of the second harmonic voltage is given by the equation:

$$V_{OPK} = \frac{P_{IN}}{(2 \pi \times f_R \times C_{OUT} \times V_{OUT})} \tag{16}$$

In this example  $V_{OPK}$  is equal to 3.91 V. Assuming an allowable contribution of 0.75% (1.5% peak to peak) from the voltage loop to the total harmonic distortion budget we set the gain equal to:

$$G_{VA} = \frac{(\Delta V_{VAOUT}) (0.015)}{2 \times V_{OPK}} \tag{17}$$

where  $\Delta V_{VAOUT}$  is the effective output voltage range of the error amplifier (5 V for the UCC3817A). The network needed to realize this filter is comprised of an input resistor,  $R_{IN}$ , and feedback components  $C_f$ ,  $C_Z$ , and  $R_f$ . The value of  $R_{IN}$  is already determined because of its function as one half of a resistor divider from  $V_{OUT}$  feeding back to the voltage amplifier for output voltage regulation. In this case the value was chosen to be 1 M $\Omega$ . This high value was chosen to reduce power dissipation in the resistor. In practice, the resistor value would be realized by the use of two 500-k $\Omega$  resistors in series because of the voltage rating constraints of most standard 1/4-W resistors. The value of  $C_f$  is determined by the equation:

$$C_f = \frac{1}{(2 \pi \times f_R \times G_{VA} \times R_{IN})} \tag{18}$$

**APPLICATION INFORMATION**

In this example  $C_f$  equals 150 nF. Resistor  $R_f$  sets the dc gain of the error amplifier and thus determines the frequency of the pole of the error amplifier. The location of the pole can be found by setting the gain of the loop equation to one and solving for the crossover frequency. The frequency, expressed in terms of input power, can be calculated by the equation:

$$f_{VI}^2 = \frac{P_{IN}}{(2\pi)^2 \times \Delta V_{VAOUT} \times V_{OUT} \times R_{IN} \times C_{OUT} \times C_f} \tag{19}$$

$f_{VI}$  for this converter is 10 Hz. A derivation of this equation can be found in the Unitrode Power Supply Design Seminar SEM1000, Topic 1, [A 250-kHz, 500-W Power Factor Correction Circuit Employing Zero Voltage Transitions].

Solving for  $R_f$  becomes:

$$R_f = \frac{1}{(2\pi \times f_{VI} \times C_f)} \tag{20}$$

or  $R_f$  equals 100 kΩ.

Due to the low output impedance of the voltage amplifier, capacitor  $C_Z$  was added in series with  $R_f$  to reduce loading on the voltage divider. To ensure the voltage loop crossed over at  $f_{VI}$ ,  $C_Z$  was selected to add a zero at a 10th of  $f_{VI}$ . For this design a 2.2-μF capacitor was chosen for  $C_Z$ . The following equation can be used to calculate  $C_Z$ .

$$C_Z = \frac{1}{2 \times \pi \times \frac{f_{VI}}{10} \times R_f} \tag{21}$$

**Current Loop**

The gain of the power stage is:

$$G_{ID}(s) = \frac{(V_{OUT} \times R_{SENSE})}{(s \times L_{BOOST} \times V_P)} \tag{22}$$

$R_{SENSE}$  has been chosen to give the desired differential voltage for the current sense amplifier at the desired current limit point. In this example, a current limit of 4 A and a reasonable differential voltage to the current amp of 1 V gives a  $R_{SENSE}$  value of 0.25 Ω.  $V_P$  in this equation is the voltage swing of the oscillator ramp, 4 V for the UCC3817A. Setting the crossover frequency of the system to 1/10th of the switching frequency, or 10 kHz, requires a power stage gain at that frequency of 0.383. In order for the system to have a gain of 1 at the crossover frequency, the current amplifier needs to have a gain of  $1/G_{ID}$  at that frequency.  $G_{EA}$ , the current amplifier gain is then:

$$G_{EA} = \frac{1}{G_{ID}} = \frac{1}{0.383} = 2.611 \tag{23}$$

**APPLICATION INFORMATION**

$R_I$  is the  $R_{MOUT}$  resistor, previously calculated to be 3.9 k $\Omega$ . (refer to Figure 3). The gain of the current amplifier is  $R_f/R_I$ , so multiplying  $R_I$  by  $G_{EA}$  gives the value of  $R_f$ , in this case approximately 12 k $\Omega$ . Setting a zero at the crossover frequency and a pole at half the switching frequency completes the current loop compensation.

$$C_Z = \frac{1}{2 \times \pi \times R_f \times f_C} \tag{24}$$

$$C_P = \frac{1}{2 \times \pi \times R_f \times \frac{f_s}{2}} \tag{25}$$

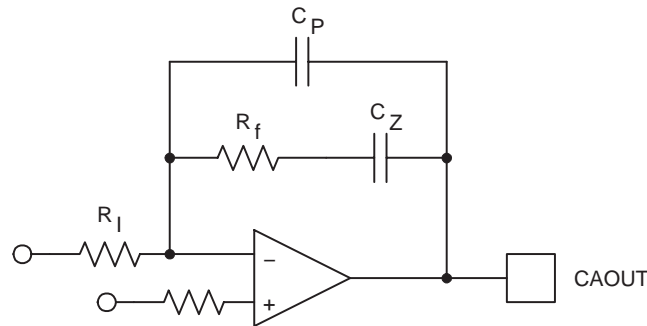

**Figure 3. Current Loop Compensation**

The UCC3817A current amplifier has the input from the multiplier applied to the inverting input. This change in architecture from previous Texas Instruments PFC controllers improves noise immunity in the current amplifier. It also adds a phase inversion into the control loop. The UCC3817A takes advantage of this phase inversion to implement leading-edge duty cycle modulation. Synchronizing a boost PFC controller to a downstream dc-to-dc controller reduces the ripple current seen by the bulk capacitor between stages, reducing capacitor size and cost and reducing EMI. This is explained in greater detail in a following section. The UCC3817A current amplifier configuration is shown in Figure 4.

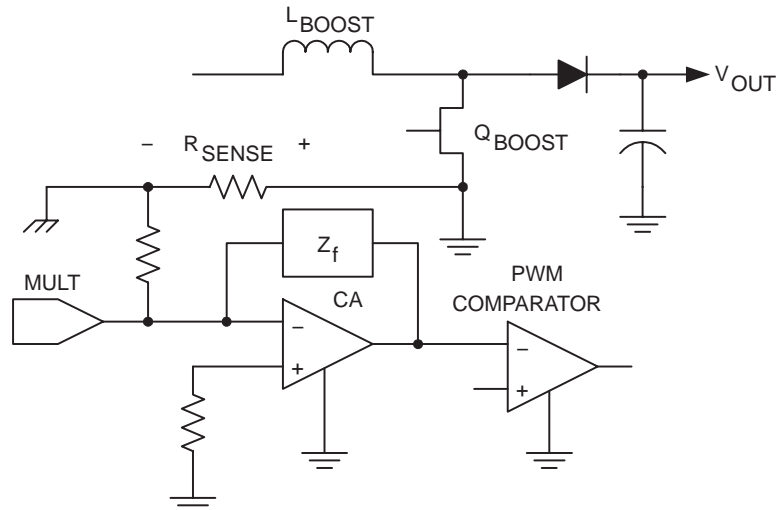

**Figure 4. UCC3817A Current Amplifier Configuration**

## APPLICATION INFORMATION

### Start Up

The UCC3818A version of the device is intended to have VCC connected to a 12-V supply voltage. The UCC3817A has an internal shunt regulator enabling the device to be powered from bootstrap circuitry as shown in the typical application circuit of Figure 1. The current drawn by the UCC3817A during undervoltage lockout, or start-up current, is typically 150  $\mu$ A. Once VCC is above the UVLO threshold, the device is enabled and draws 4 mA typically. A resistor connected between the rectified ac line voltage and the VCC pin provides current to the shunt regulator during power up. Once the circuit is operational, the bootstrap winding of the inductor provides the VCC voltage. Sizing of the start-up resistor is determined by the start-up time requirement of the system design.

$$I_C = C \frac{\Delta V}{\Delta t} \quad (26)$$

$$R = \frac{V_{RMS} \times (0.9)}{I_C} \quad (27)$$

Where  $I_C$  is the charge current, C is the total capacitance at the VCC pin,  $\Delta V$  is the UVLO threshold and  $\Delta t$  is the allowed start-up time.

Assuming a 1 second allowed start-up time, a 16-V UVLO threshold, and a total VCC capacitance of 100  $\mu$ F, a resistor value of 51 k $\Omega$  is required at a low line input voltage of 85  $V_{RMS}$ . The IC start-up current is sufficiently small as to be ignored in sizing the start-up resistor.

### Capacitor Ripple Reduction

For a power system where the PFC boost converter is followed by a dc-to-dc converter stage, there are benefits to synchronizing the two converters. In addition to the usual advantages such as noise reduction and stability, proper synchronization can significantly reduce the ripple currents in the boost circuit's output capacitor. Figure 5 helps illustrate the impact of proper synchronization by showing a PFC boost converter together with the simplified input stage of a forward converter. The capacitor current during a single switching cycle depends on the status of the switches Q1 and Q2 and is shown in Figure 6. It can be seen that with a synchronization scheme that maintains conventional trailing-edge modulation on both converters, the capacitor current ripple is highest. The greatest ripple current cancellation is attained when the overlap of Q1 offtime and Q2 ontime is maximized. One method of achieving this is to synchronize the turnon of the boost diode (D1) with the turnon of Q2. This approach implies that the boost converter's leading edge is pulse width modulated while the forward converter is modulated with traditional trailing edge PWM. The UCC3817A is designed as a leading edge modulator with easy synchronization to the downstream converter to facilitate this advantage. Table 1 compares the  $I_{CB(rms)}$  for D1/Q2 synchronization as offered by UCC3817A vs. the  $I_{CB(rms)}$  for the other extreme of synchronizing the turnon of Q1 and Q2 for a 200-W power system with a  $V_{BST}$  of 385 V.



APPLICATION INFORMATION

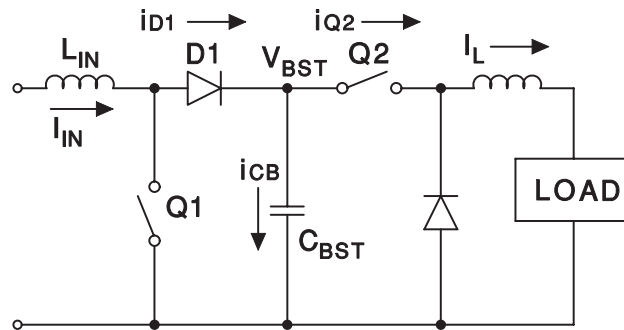

UDG-97130-1

Figure 5. Simplified Representation of a 2-Stage PFC Power Supply

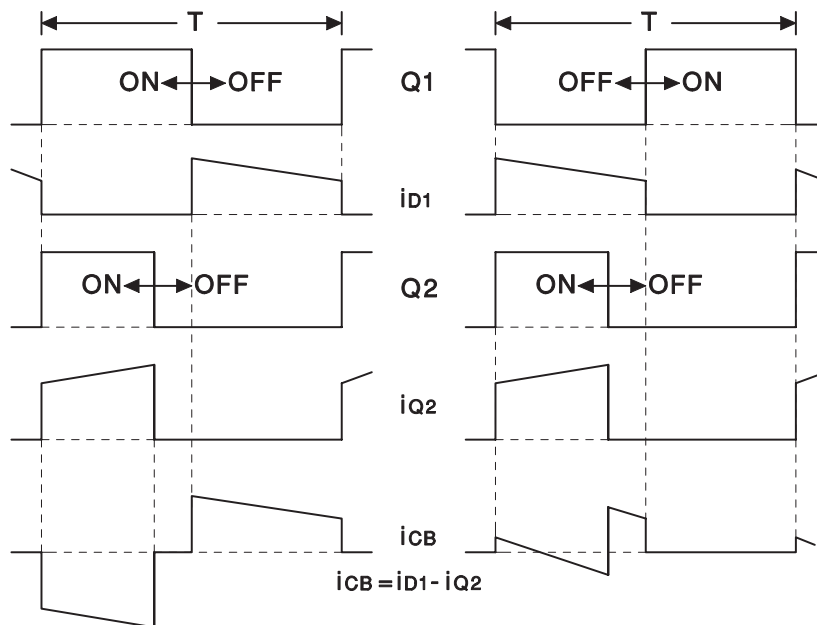

UDG-97131

Figure 6. Timing Waveforms for Synchronization Scheme

**APPLICATION INFORMATION**

Table 1 illustrates that the boost capacitor ripple current can be reduced by about 50% at nominal line and about 30% at high line with the synchronization scheme facilitated by the UCC3817A. Figure 7 shows the suggested technique for synchronizing the UCC3817A to the downstream converter. With this technique, maximum ripple reduction as shown in Figure 6 is achievable. The output capacitance value can be significantly reduced if its choice is dictated by ripple current or the capacitor life can be increased as a result. In cost sensitive designs where holdup time is not critical, this is a significant advantage.

**Table 1. Effects of Synchronization on Boost Capacitor Current**

| D(Q2) | V <sub>IN</sub> = 85 V |         | V <sub>IN</sub> = 120 V |         | V <sub>IN</sub> = 240 V |         |
|-------|------------------------|---------|-------------------------|---------|-------------------------|---------|
|       | Q1/Q2                  | D1/Q2   | Q1/Q2                   | D1/Q2   | Q1/Q2                   | D1/Q2   |
| 0.35  | 1.491 A                | 0.835 A | 1.341 A                 | 0.663 A | 1.024 A                 | 0.731 A |
| 0.45  | 1.432 A                | 0.93 A  | 1.276 A                 | 0.664 A | 0.897 A                 | 0.614 A |

An alternative method of synchronization to achieve the same ripple reduction is possible. In this method, the turnon of Q1 is synchronized to the turnoff of Q2. While this method yields almost identical ripple reduction and maintains trailing edge modulation on both converters, the synchronization is much more difficult to achieve and the circuit can become susceptible to noise as the synchronizing edge itself is being modulated.

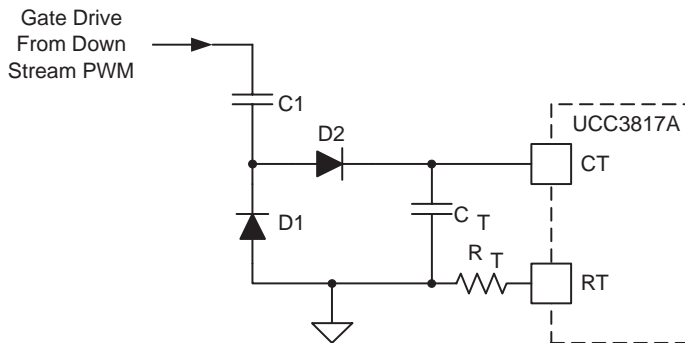

**Figure 7. Synchronizing the UCC3817A to a Down-Stream Converter**

**APPLICATION INFORMATION**

**REFERENCE VOLTAGE  
VS  
SUPPLY VOLTAGE**

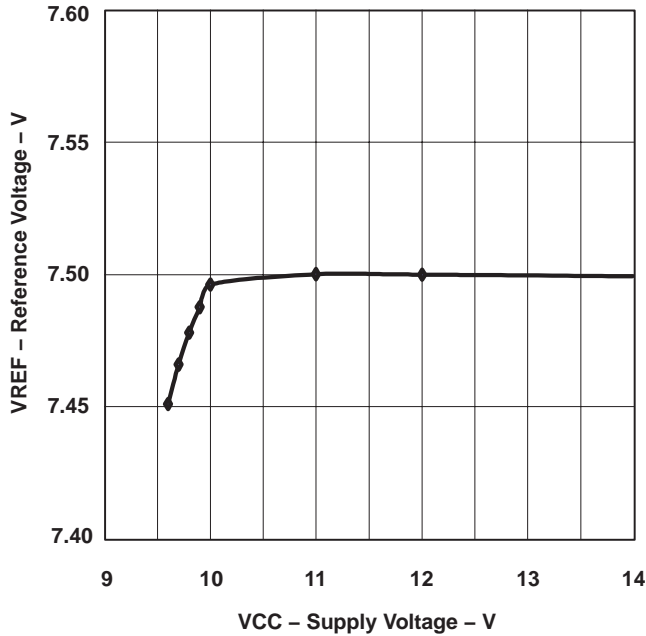

**Figure 8**

**REFERENCE VOLTAGE  
VS  
REFERENCE CURRENT**

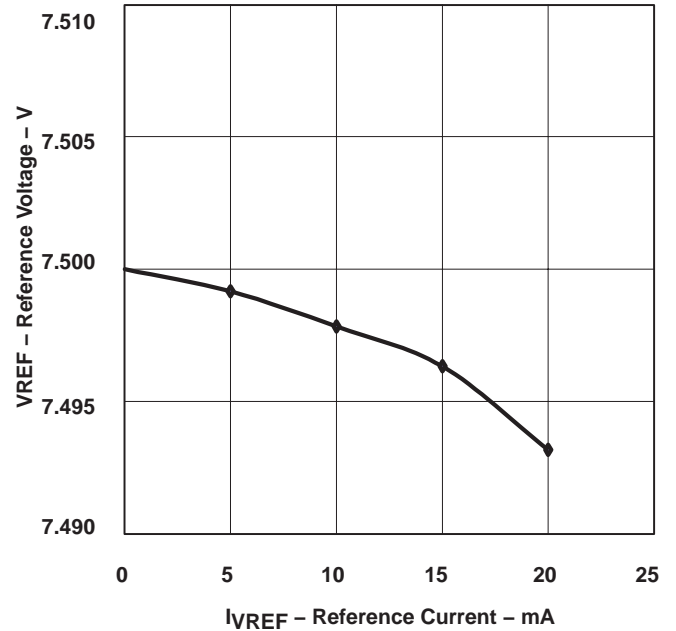

**Figure 9**

**MULTIPLIER OUTPUT CURRENT  
VS  
VOLTAGE ERROR AMPLIFIER OUTPUT**

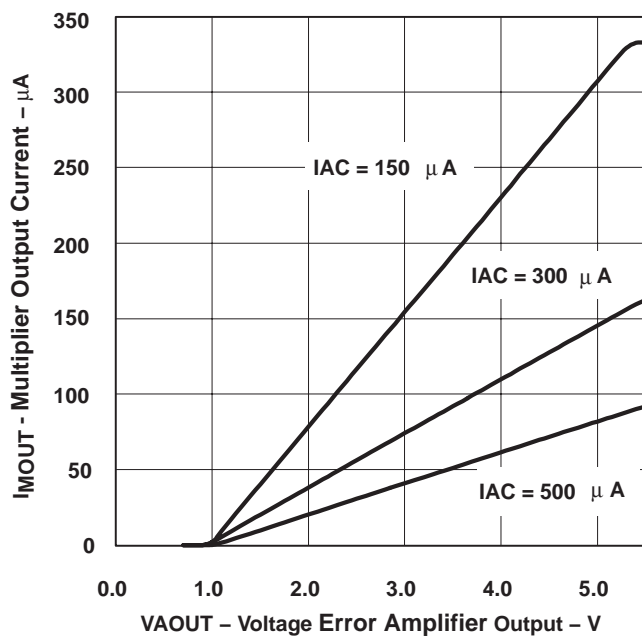

**Figure 10**

**MULTIPLIER GAIN  
VS  
VOLTAGE ERROR AMPLIFIER OUTPUT**

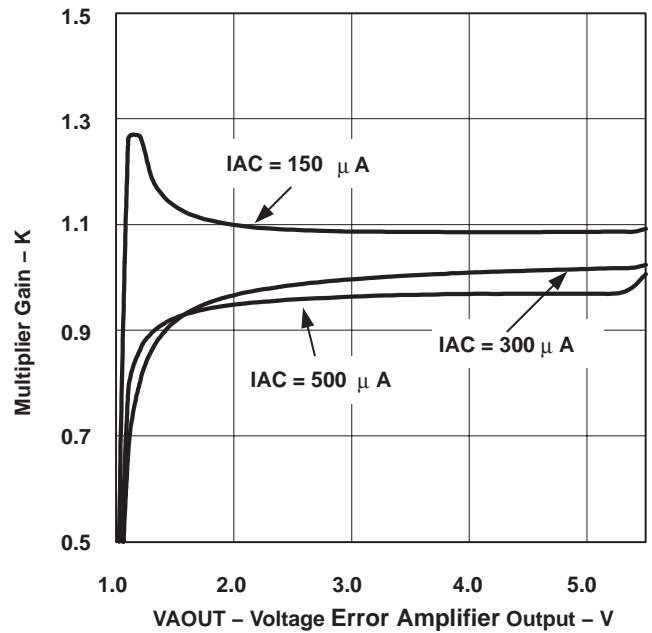

**Figure 11**

**APPLICATION INFORMATION**

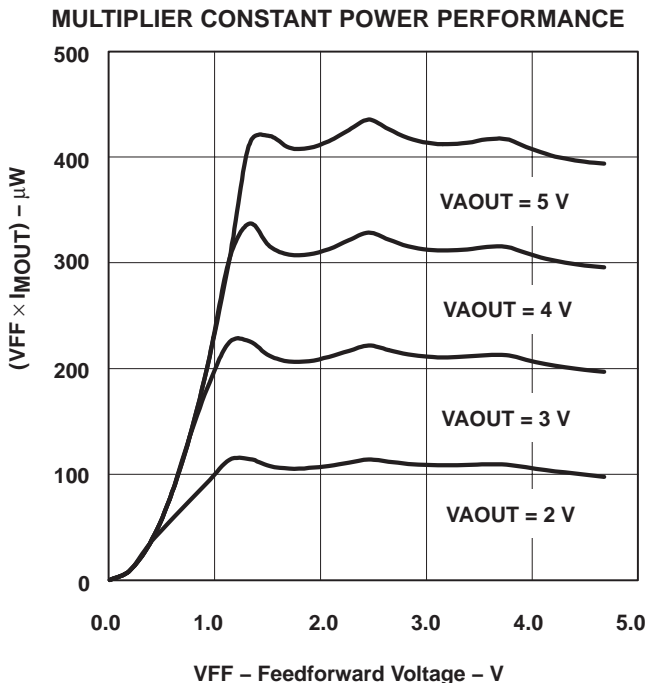

**Figure 12**

**References and Resources:**

Application Note, *Differences Between UCC3817A/18A/19A and UCC3817/18/19*, Texas Instruments Literature Number SLUA294

Evaluation Module, UCC3817EVM, 385V, 250W PFC Boost Converter

User's Guide, *UCC3817 BiCMOS Power Factor Preregulator Evaluation Board*, Texas Instruments Literature Number SLUU077

Application Note, *Synchronizing a PFC Controller from a Down Stream Controller Gate Drive*, Texas Instruments Literature Number SLUA245

Seminar topic, *High Power Factor Switching Preregulator Design Optimization*, L.H. Dixon, SEM-700,1990.

Seminar topic, *High Power Factor Preregulator for Off-line Supplies*, L.H. Dixon, SEM-600, 1988.

**Related Products**

| DEVICE            | DESCRIPTION                                    | CONTROL METHOD     | TYPICAL POWER LEVEL |
|-------------------|--|--------------------|---------------------|
| UC3854            | PFC controller                                 | ACM <sup>(2)</sup> | 200 W to 2 kW+      |
| UC3854A/B         | Improved PFC controller                        | ACM <sup>(2)</sup> | 200 W to 2 kW+      |
| UC3855A/B         | High performance soft switching PFC controller | ACM <sup>(2)</sup> | 400 W to 2 kW+      |
| UCC38050/1        | Transition mode PFC controller                 | CRM <sup>(1)</sup> | 50 W to 400 W       |
| UCC3819           | Tracking boost PFC controller                  | ACM <sup>(2)</sup> | 75 W to 2 kW+       |
| UCC28510/11/12/13 | Advanced PFC+PWM combo controller              | ACM <sup>(2)</sup> | 75 W to 1kW+        |
| UCC28514/15/16/17 | Advanced PFC+PWM combo controller              | ACM <sup>(2)</sup> | 75 W to 1kW+        |

NOTES: (1). Critical conduction mode  
(2). Average current mode

**MECHANICAL DATA**

**D (R-PDSO-G\*\*)**

**PLASTIC SMALL-OUTLINE PACKAGE**

**8 PINS SHOWN**

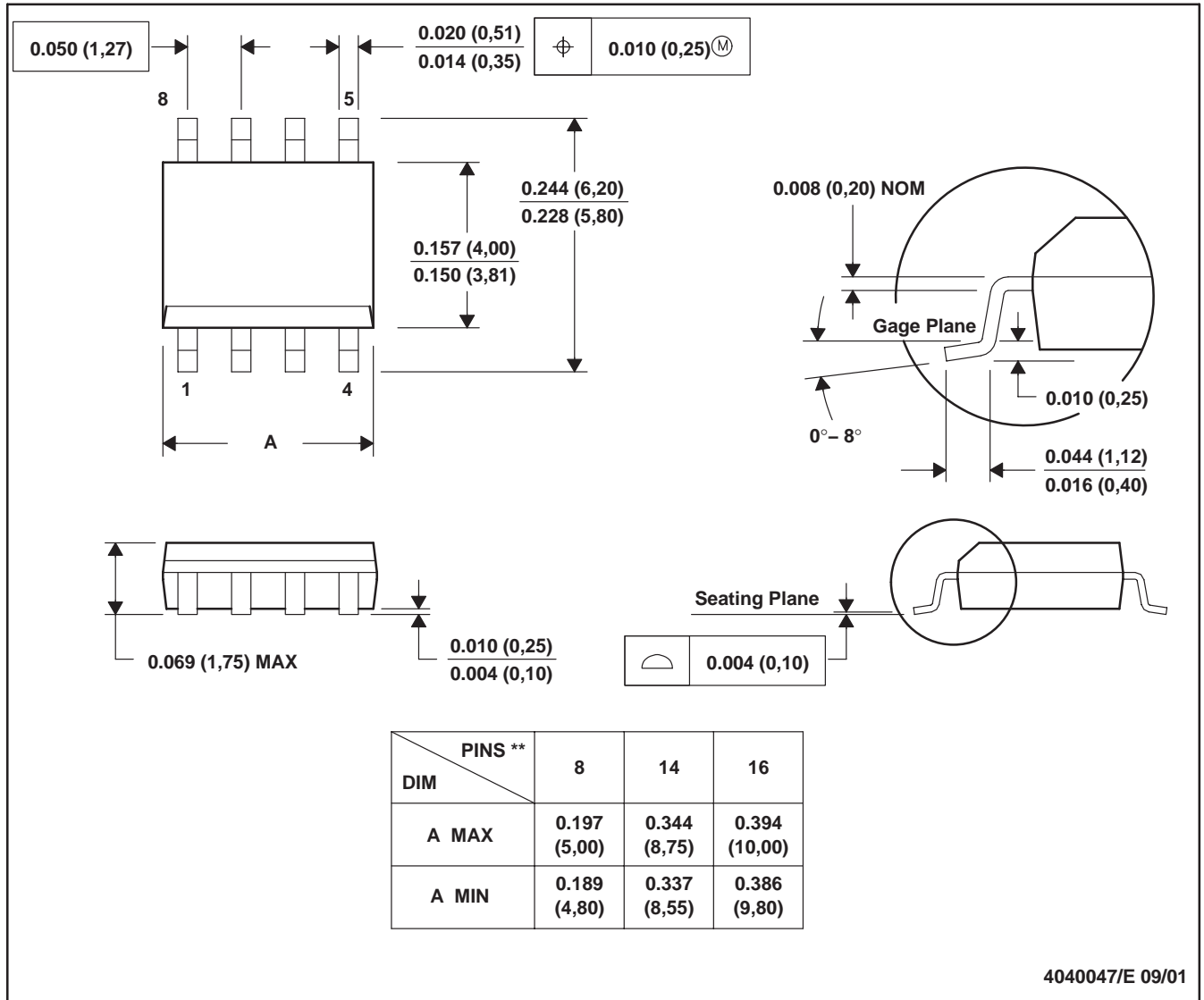

- NOTES: A. All linear dimensions are in inches (millimeters).  
 B. This drawing is subject to change without notice.  
 C. Body dimensions do not include mold flash or protrusion, not to exceed 0.006 (0,15).

# UCC2817A, UCC2818A UCC3817A, UCC3818A

SLUS577A – SEPTEMBER, 2003 – REVISED OCTOBER 2003

## MECHANICAL DATA

N (R-PDIP-T\*\*)

PLASTIC DUAL-IN-LINE PACKAGE

16 PINS SHOWN

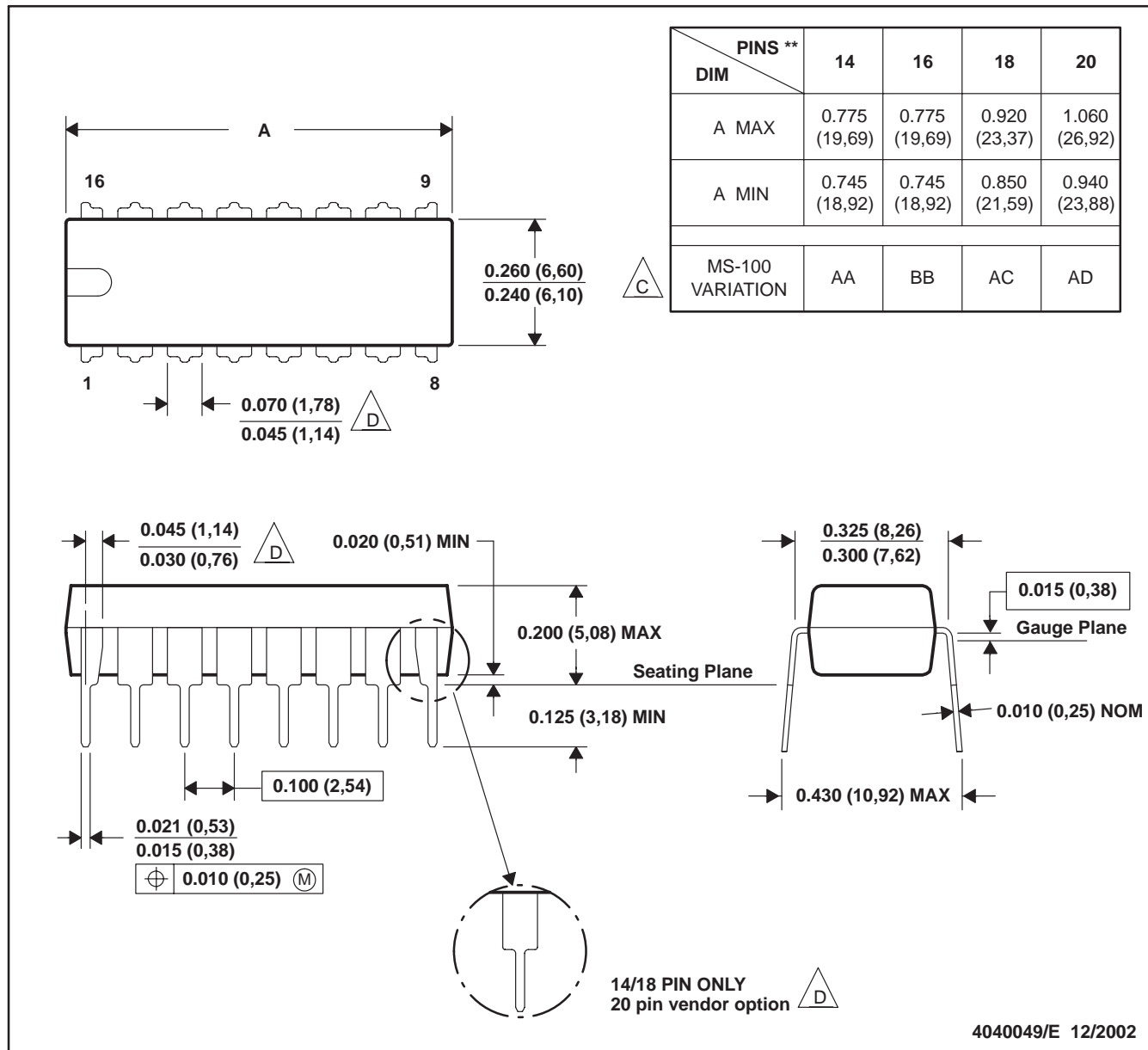

- NOTES: D. All linear dimensions are in inches (millimeters).  
 E. This drawing is subject to change without notice.  
 F. Falls within JEDEC MS-001, except 18 and 20 pin minimum body length (Dim A).  
 G. The 20 pin end lead shoulder width is a vendor option, either half or full width.

**MECHANICAL DATA**

**PW (R-PDSO-G\*\*)**

**PLASTIC SMALL-OUTLINE PACKAGE**

14 PINS SHOWN

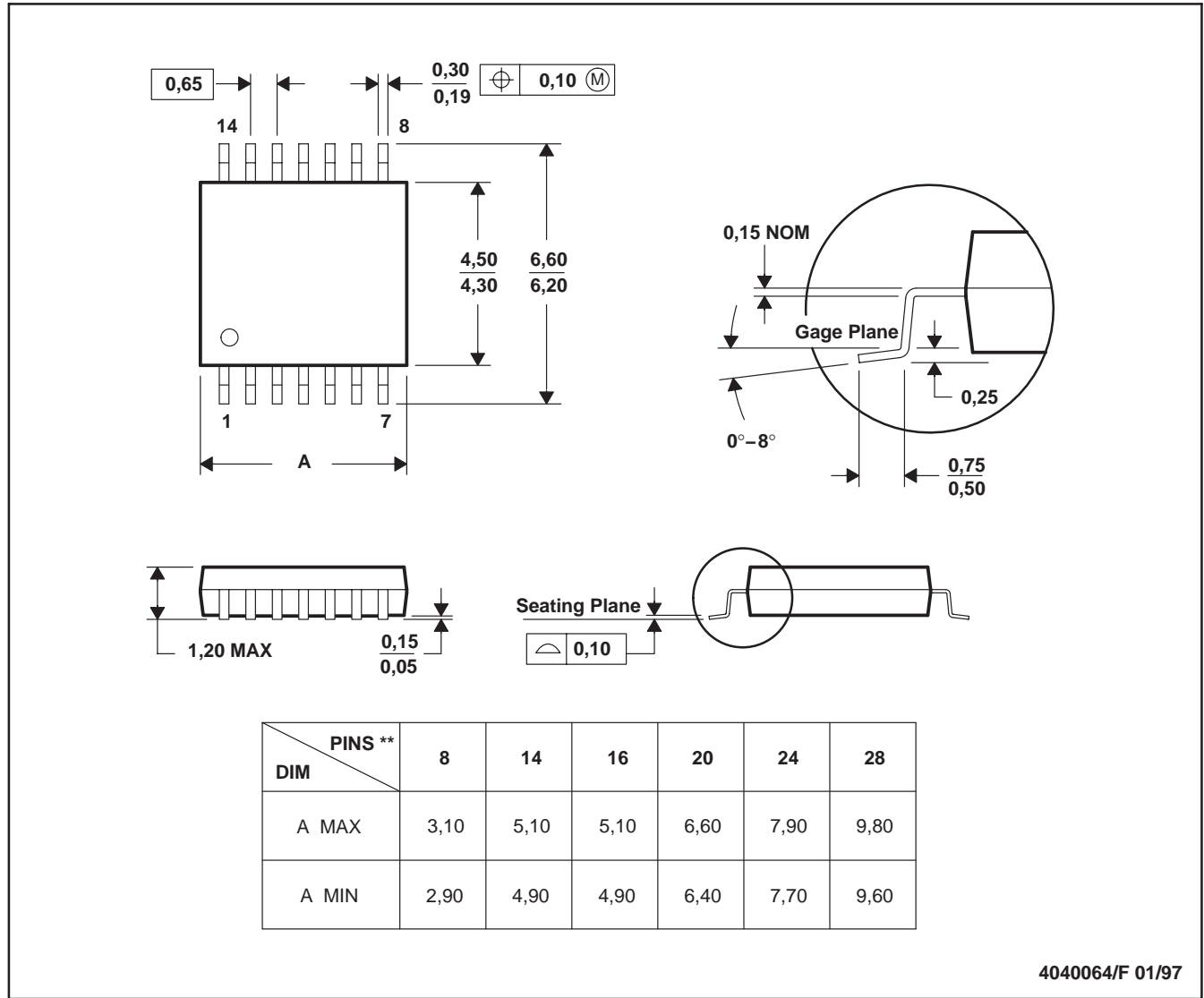

- NOTES: H. All linear dimensions are in millimeters.  
 I. This drawing is subject to change without notice.  
 J. Body dimensions do not include mold flash or protrusion not to exceed 0,15.

N (R-PDIP-T\*\*)

PLASTIC DUAL-IN-LINE PACKAGE

16 PINS SHOWN

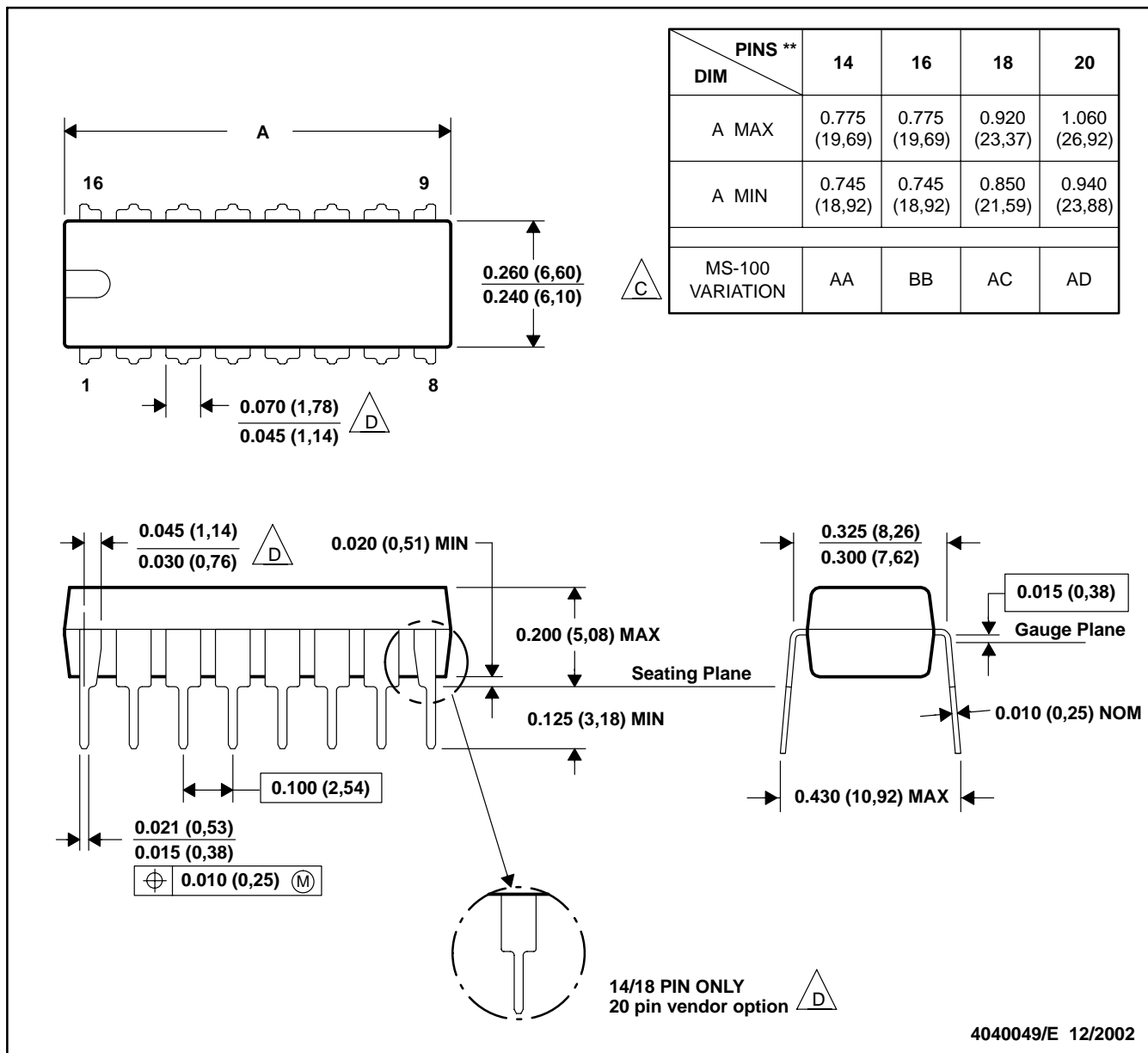

- NOTES: A. All linear dimensions are in inches (millimeters).  
 B. This drawing is subject to change without notice.  
 C Falls within JEDEC MS-001, except 18 and 20 pin minimum body length (Dim A).  
 D The 20 pin end lead shoulder width is a vendor option, either half or full width.

4040049/E 12/2002



D (R-PDSO-G\*\*)

PLASTIC SMALL-OUTLINE PACKAGE

8 PINS SHOWN

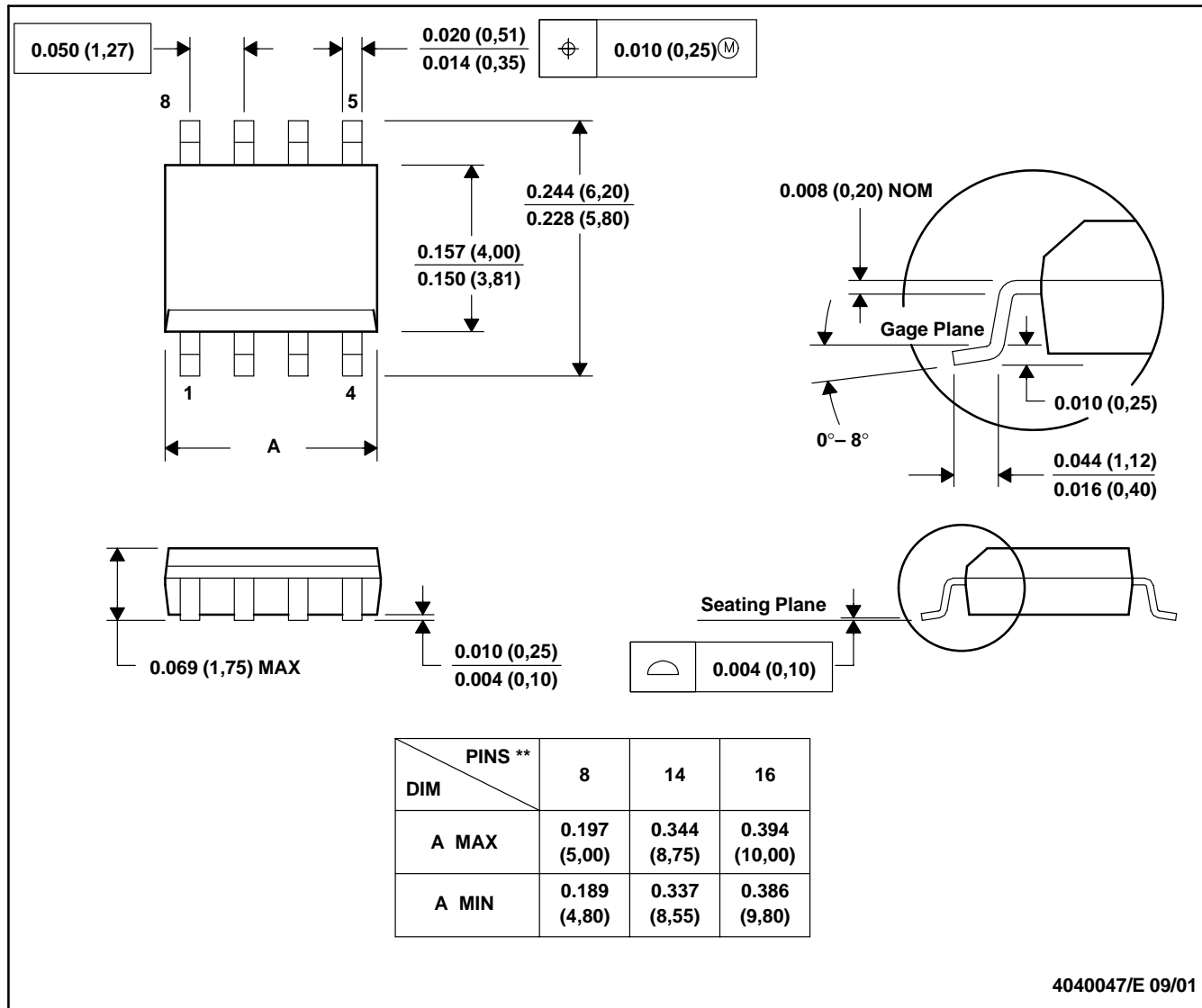

4040047/E 09/01

- NOTES: A. All linear dimensions are in inches (millimeters).  
 B. This drawing is subject to change without notice.  
 C. Body dimensions do not include mold flash or protrusion, not to exceed 0.006 (0,15).  
 D. Falls within JEDEC MS-012

PW (R-PDSO-G\*\*)

PLASTIC SMALL-OUTLINE PACKAGE

14 PINS SHOWN

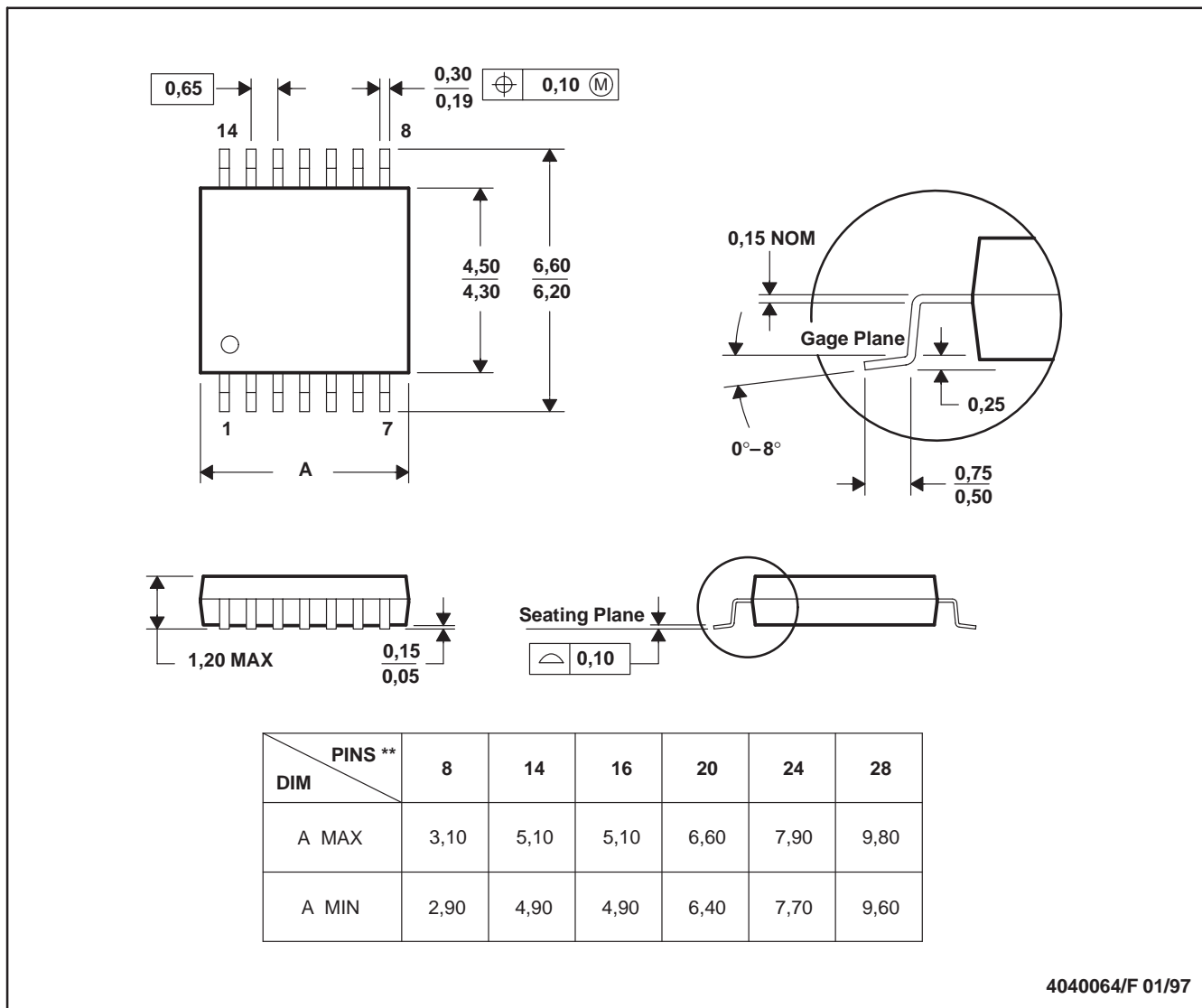

4040064/F 01/97

- NOTES: A. All linear dimensions are in millimeters.  
 B. This drawing is subject to change without notice.  
 C. Body dimensions do not include mold flash or protrusion not to exceed 0,15.  
 D. Falls within JEDEC MO-153

## IMPORTANT NOTICE

Texas Instruments Incorporated and its subsidiaries (TI) reserve the right to make corrections, modifications, enhancements, improvements, and other changes to its products and services at any time and to discontinue any product or service without notice. Customers should obtain the latest relevant information before placing orders and should verify that such information is current and complete. All products are sold subject to TI's terms and conditions of sale supplied at the time of order acknowledgment.

TI warrants performance of its hardware products to the specifications applicable at the time of sale in accordance with TI's standard warranty. Testing and other quality control techniques are used to the extent TI deems necessary to support this warranty. Except where mandated by government requirements, testing of all parameters of each product is not necessarily performed.

TI assumes no liability for applications assistance or customer product design. Customers are responsible for their products and applications using TI components. To minimize the risks associated with customer products and applications, customers should provide adequate design and operating safeguards.

TI does not warrant or represent that any license, either express or implied, is granted under any TI patent right, copyright, mask work right, or other TI intellectual property right relating to any combination, machine, or process in which TI products or services are used. Information published by TI regarding third-party products or services does not constitute a license from TI to use such products or services or a warranty or endorsement thereof. Use of such information may require a license from a third party under the patents or other intellectual property of the third party, or a license from TI under the patents or other intellectual property of TI.

Reproduction of information in TI data books or data sheets is permissible only if reproduction is without alteration and is accompanied by all associated warranties, conditions, limitations, and notices. Reproduction of this information with alteration is an unfair and deceptive business practice. TI is not responsible or liable for such altered documentation.

Resale of TI products or services with statements different from or beyond the parameters stated by TI for that product or service voids all express and any implied warranties for the associated TI product or service and is an unfair and deceptive business practice. TI is not responsible or liable for any such statements.

Following are URLs where you can obtain information on other Texas Instruments products and application solutions:

| <b>Products</b>  |  | <b>Applications</b> |  |
|------------------|--|---------------------|--|
| Amplifiers       | <a href="http://amplifier.ti.com">amplifier.ti.com</a>             | Audio               | <a href="http://www.ti.com/audio">www.ti.com/audio</a>                   |
| Data Converters  | <a href="http://dataconverter.ti.com">dataconverter.ti.com</a>     | Automotive          | <a href="http://www.ti.com/automotive">www.ti.com/automotive</a>         |
| DSP              | <a href="http://dsp.ti.com">dsp.ti.com</a>                         | Broadband           | <a href="http://www.ti.com/broadband">www.ti.com/broadband</a>           |
| Interface        | <a href="http://interface.ti.com">interface.ti.com</a>             | Digital Control     | <a href="http://www.ti.com/digitalcontrol">www.ti.com/digitalcontrol</a> |
| Logic            | <a href="http://logic.ti.com">logic.ti.com</a>                     | Military            | <a href="http://www.ti.com/military">www.ti.com/military</a>             |
| Power Mgmt       | <a href="http://power.ti.com">power.ti.com</a>                     | Optical Networking  | <a href="http://www.ti.com/opticalnetwork">www.ti.com/opticalnetwork</a> |
| Microcontrollers | <a href="http://microcontroller.ti.com">microcontroller.ti.com</a> | Security            | <a href="http://www.ti.com/security">www.ti.com/security</a>             |
|                  |  | Telephony           | <a href="http://www.ti.com/telephony">www.ti.com/telephony</a>           |
|                  |  | Video & Imaging     | <a href="http://www.ti.com/video">www.ti.com/video</a>                   |
|                  |  | Wireless            | <a href="http://www.ti.com/wireless">www.ti.com/wireless</a>             |

Mailing Address: Texas Instruments  
Post Office Box 655303 Dallas, Texas 75265

Copyright © 2003, Texas Instruments Incorporated