

SN54LVTH543, SN74LVTH543 3.3-V ABT OCTAL REGISTERED TRANSCEIVERS WITH 3-STATE OUTPUTS

SCBS704F – AUGUST 1997 – REVISED OCTOBER 2003

- Support Mixed-Mode Signal Operation (5-V Input and Output Voltages With 3.3-V V_{CC})
- Typical V_{OLP} (Output Ground Bounce) <0.8 V at $V_{CC} = 3.3$ V, $T_A = 25^\circ\text{C}$
- Support Unregulated Battery Operation Down to 2.7 V
- I_{off} and Power-Up 3-State Support Hot Insertion
- Bus Hold on Data Inputs Eliminates the Need for External Pullup/Pulldown Resistors
- Latch-Up Performance Exceeds 500 mA Per JESD 17
- ESD Protection Exceeds JESD 22
 - 2000-V Human-Body Model (A114-A)
 - 200-V Machine Model (A115-A)

SN54LVTH543 . . . JT OR W PACKAGE
SN74LVTH543 . . . DB, DGV, DW, NS, OR PW PACKAGE
(TOP VIEW)

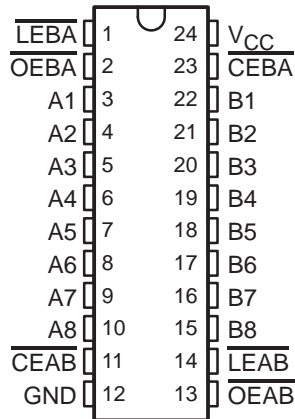

SN54LVTH543 . . . FK PACKAGE
(TOP VIEW)

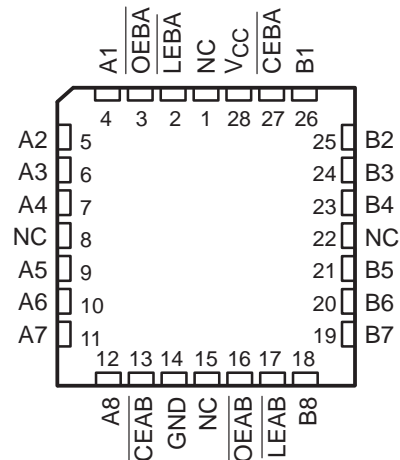

NC – No internal connection

description/ordering information

These octal transceivers are designed specifically for low-voltage (3.3-V) V_{CC} operation, but with the capability to provide a TTL interface to a 5-V system environment.

ORDERING INFORMATION

T_A	PACKAGE†		ORDERABLE PART NUMBER	TOP-SIDE MARKING
–40°C to 85°C	SOIC – DW	Tube	SN74LVTH543DW	LVTH543
		Tape and reel	SN74LVTH543DWR	
	SOP – NS	Tape and reel	SN74LVTH543NSR	LVTH543
	SSOP – DB	Tape and reel	SN74LVTH543DBR	LXH543
	TSSOP – PW	Tube	SN74LVTH543PW	LXH543
		Tape and reel	SN74LVTH543PWR	
	TVSOP – DGV	Tape and reel	SN74LVTH543DGVR	LXH543
–55°C to 125°C	CDIP – JT	Tube	SNJ54LVTH543JT	SNJ54LVTH543JT
	CFP – W	Tube	SNJ54LVTH543W	SNJ54LVTH543W
	LCCC – FK	Tube	SNJ54LVTH543FK	SNJ54LVTH543FK

† Package drawings, standard packing quantities, thermal data, symbolization, and PCB design guidelines are available at www.ti.com/sc/package.



Please be aware that an important notice concerning availability, standard warranty, and use in critical applications of Texas Instruments semiconductor products and disclaimers thereto appears at the end of this data sheet.

UNLESS OTHERWISE NOTED this document contains PRODUCTION DATA information current as of publication date. Products conform to specifications per the terms of Texas Instruments standard warranty. Production processing does not necessarily include testing of all parameters.

**TEXAS
INSTRUMENTS**

POST OFFICE BOX 655303 • DALLAS, TEXAS 75265

Copyright © 2003, Texas Instruments Incorporated

SN54LVTH543, SN74LVTH543

3.3-V ABT OCTAL REGISTERED TRANSCEIVERS WITH 3-STATE OUTPUTS

SCBS704F – AUGUST 1997 – REVISED OCTOBER 2003

description/ordering information (continued)

The 'LVTH543 devices contain two sets of D-type latches for temporary storage of data flowing in either direction. Separate latch-enable (\overline{LEAB} or \overline{LEBA}) and output-enable (\overline{OEAB} or \overline{OEBA}) inputs are provided for each register, to permit independent control in either direction of data flow.

The A-to-B enable (\overline{CEAB}) input must be low to enter data from A or to output data from B. If \overline{CEAB} is low and \overline{LEAB} is low, the A-to-B latches are transparent; a subsequent low-to-high transition of \overline{LEAB} puts the A latches in the storage mode. With \overline{CEAB} and \overline{OEAB} both low, the 3-state B outputs are active and reflect the data present at the output of the A latches. Data flow from B to A is similar, but requires using the \overline{CEBA} , \overline{LEBA} , and \overline{OEBA} inputs.

Active bus-hold circuitry holds unused or undriven inputs at a valid logic state. Use of pullup or pulldown resistors with the bus-hold circuitry is not recommended.

When V_{CC} is between 0 and 1.5 V, the device is in the high-impedance state during power up or power down. However, to ensure the high-impedance state above 1.5 V, \overline{OE} should be tied to V_{CC} through a pullup resistor; the minimum value of the resistor is determined by the current-sinking capability of the driver.

This device is fully specified for hot-insertion applications using I_{off} and power-up 3-state. The I_{off} circuitry disables the outputs, preventing damaging current backflow through the device when it is powered down. The power-up 3-state circuitry places the outputs in the high-impedance state during power up and power down, which prevents driver conflict.

FUNCTION TABLE†

INPUTS				OUTPUT
\overline{CEAB}	\overline{LEAB}	\overline{OEAB}	A	B
H	X	X	X	Z
X	X	H	X	Z
L	H	L	X	B_0^\ddagger
L	L	L	L	L
L	L	L	H	H

† A-to-B data flow is shown; B-to-A flow control is the same, except that it uses \overline{CEBA} , \overline{LEBA} , and \overline{OEBA} .

‡ Output level before the indicated steady-state input conditions were established



SN54LVTH543, SN74LVTH543 3.3-V ABT OCTAL REGISTERED TRANSCEIVERS WITH 3-STATE OUTPUTS

SCBS704F – AUGUST 1997 – REVISED OCTOBER 2003

logic diagram (positive logic)

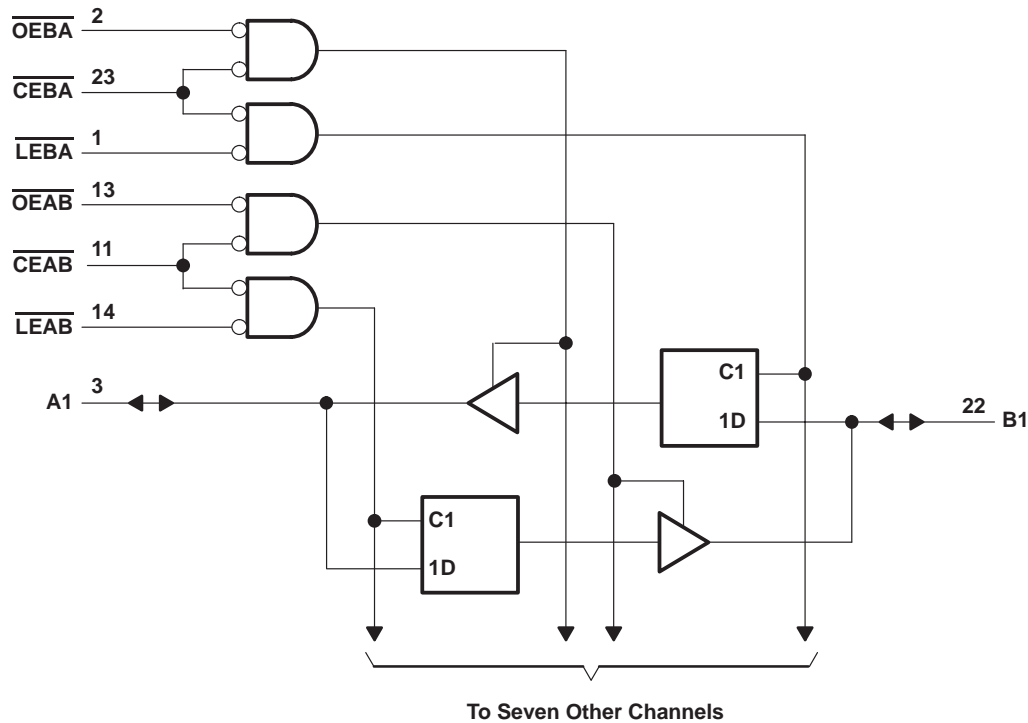

Pin numbers shown are for the DB, DGV, DW, JT, NS, PW, and W packages.

absolute maximum ratings over operating free-air temperature range (unless otherwise noted)[†]

Supply voltage range, V_{CC}	-0.5 V to 4.6 V
Input voltage range, V_I (see Note 1)	-0.5 V to 7 V
Voltage range applied to any output in the high-impedance or power-off state, V_O (see Note 1)	-0.5 V to 7 V
Voltage range applied to any output in the high state, V_O (see Note 1)	-0.5 V to $V_{CC} + 0.5$ V
Current into any output in the low state, I_O : SN54LVTH543	96 mA
SN74LVTH543	128 mA
Current into any output in the high state, I_O (see Note 2): SN54LVTH543	48 mA
SN74LVTH543	64 mA
Input clamp current, I_{IK} ($V_I < 0$)	-50 mA
Output clamp current, I_{OK} ($V_O < 0$)	-50 mA
Package thermal impedance, θ_{JA} (see Note 3): DB package	63°C/W
DGV package	86°C/W
DW package	46°C/W
NS package	65°C/W
PW package	88°C/W
Storage temperature range, T_{stg}	-65°C to 150°C

[†] Stresses beyond those listed under "absolute maximum ratings" may cause permanent damage to the device. These are stress ratings only, and functional operation of the device at these or any other conditions beyond those indicated under "recommended operating conditions" is not implied. Exposure to absolute-maximum-rated conditions for extended periods may affect device reliability.

- NOTES: 1. The input and output negative-voltage ratings may be exceeded if the input and output clamp-current ratings are observed.
 2. This current flows only when the output is in the high state and $V_O > V_{CC}$.
 3. The package thermal impedance is calculated in accordance with JESD 51-7.



SN54LVTH543, SN74LVTH543

3.3-V ABT OCTAL REGISTERED TRANSCEIVERS WITH 3-STATE OUTPUTS

SCBS704F – AUGUST 1997 – REVISED OCTOBER 2003

recommended operating conditions (see Note 4)

		SN54LVTH543		SN74LVTH543		UNIT
		MIN	MAX	MIN	MAX	
V _{CC}	Supply voltage	2.7	3.6	2.7	3.6	V
V _{IH}	High-level input voltage	2		2		V
V _{IL}	Low-level input voltage		0.8		0.8	V
V _I	Input voltage		5.5		5.5	V
I _{OH}	High-level output current		-24		-32	mA
I _{OL}	Low-level output current		48		64	mA
Δt/Δv	Input transition rise or fall rate	Outputs enabled		10	10	ns/V
Δt/ΔV _{CC}	Power-up ramp rate	200		200		μs/V
T _A	Operating free-air temperature	-55	125	-40	85	°C

NOTE 4: All unused control inputs of the device must be held at V_{CC} or GND to ensure proper device operation. Refer to the TI application report, *Implications of Slow or Floating CMOS Inputs*, literature number SCBA004.

SN54LVTH543, SN74LVTH543 3.3-V ABT OCTAL REGISTERED TRANSCEIVERS WITH 3-STATE OUTPUTS

SCBS704F – AUGUST 1997 – REVISED OCTOBER 2003

electrical characteristics over recommended operating free-air temperature range (unless otherwise noted)

PARAMETER		TEST CONDITIONS		SN54LVTH543		SN74LVTH543		UNIT		
				MIN	TYP†	MAX	MIN		TYP†	MAX
V_{IK}		$V_{CC} = 2.7\text{ V}$, $I_I = -18\text{ mA}$		-1.2		-1.2		V		
V_{OH}		$V_{CC} = 2.7\text{ V to }3.6\text{ V}$, $I_{OH} = -100\text{ }\mu\text{A}$		$V_{CC}-0.2$		$V_{CC}-0.2$		V		
		$V_{CC} = 2.7\text{ V}$, $I_{OH} = -8\text{ mA}$		2.4		2.4				
		$V_{CC} = 3\text{ V}$		$I_{OH} = -24\text{ mA}$		2			2	
V_{OL}		$V_{CC} = 2.7\text{ V}$		$I_{OL} = 100\text{ }\mu\text{A}$		0.2		0.2	V	
				$I_{OL} = 24\text{ mA}$		0.5		0.5		
		$V_{CC} = 3\text{ V}$		$I_{OL} = 16\text{ mA}$		0.4		0.4		
				$I_{OL} = 32\text{ mA}$		0.5		0.5		
				$I_{OL} = 48\text{ mA}$		0.55		0.55		
I_I		Control inputs $V_{CC} = 3.6\text{ V}$, $V_I = V_{CC}\text{ or GND}$ $V_{CC} = 0\text{ or }3.6\text{ V}$, $V_I = 5.5\text{ V}$		± 1		± 1		μA		
				10		10				
		A or B ports‡ $V_{CC} = 3.6\text{ V}$		$V_I = 5.5\text{ V}$		20			20	
				$V_I = V_{CC}$ $V_I = 0$		1 -5			1 -5	
I_{off}		$V_{CC} = 0$, $V_I\text{ or }V_O = 0\text{ to }4.5\text{ V}$				± 100		μA		
$I_{I(\text{hold})}$		A or B ports $V_{CC} = 3\text{ V}$		$V_I = 0.8\text{ V}$		75		μA		
				$V_I = 2\text{ V}$		-75			-75	
		$V_{CC} = 3.6\text{ V}\S$		$V_I = 0\text{ to }3.6\text{ V}$		± 500				
I_{OZPU}		$V_{CC} = 0\text{ to }1.5\text{ V}$, $V_O = 0.5\text{ to }3\text{ V}$, $OE = \text{don't care}$		$\pm 100^*$		± 100		μA		
I_{OZPD}		$V_{CC} = 1.5\text{ V to }0$, $V_O = 0.5\text{ to }3\text{ V}$, $OE = \text{don't care}$		$\pm 100^*$		± 100		μA		
I_{CC}		$V_{CC} = 3.6\text{ V}$, $I_O = 0$, $V_I = V_{CC}\text{ or GND}$		Outputs high		0.19		0.19	mA	
				Outputs low		5		5		
				Outputs disabled		0.19		0.19		
$\Delta I_{CC}\P$		$V_{CC} = 3\text{ V to }3.6\text{ V}$, One input at $V_{CC} - 0.6\text{ V}$, Other inputs at $V_{CC}\text{ or GND}$		0.2		0.2		mA		
C_i		$V_I = 3\text{ V or }0$		4		4		pF		
C_{io}		$V_O = 3\text{ V or }0$		9		9		pF		

* On products compliant to MIL-PRF-38535, this parameter is not production tested.

† All typical values are at $V_{CC} = 3.3\text{ V}$, $T_A = 25^\circ\text{C}$.

‡ Unused terminals are at V_{CC} or GND.

§ This is the bus-hold maximum dynamic current. It is the minimum overdrive current required to switch the input from one state to another.

P This is the increase in supply current for each input that is at the specified TTL voltage level, rather than V_{CC} or GND.

PRODUCT PREVIEW information concerns products in the formative or design phase of development. Characteristic data and other specifications are design goals. Texas Instruments reserves the right to change or discontinue these products without notice.



POST OFFICE BOX 655303 • DALLAS, TEXAS 75265

SN54LVTH543, SN74LVTH543

3.3-V ABT OCTAL REGISTERED TRANSCEIVERS

WITH 3-STATE OUTPUTS

SCBS704F – AUGUST 1997 – REVISED OCTOBER 2003

timing requirements over recommended operating free-air temperature range (unless otherwise noted) (see Figure 1)

			SN54LVTH543				SN74LVTH543				UNIT
			$V_{CC} = 3.3\text{ V} \pm 0.3\text{ V}$		$V_{CC} = 2.7\text{ V}$		$V_{CC} = 3.3\text{ V} \pm 0.3\text{ V}$		$V_{CC} = 2.7\text{ V}$		
			MIN	MAX	MIN	MAX	MIN	MAX	MIN	MAX	
t_w	Pulse duration,	$\overline{\text{LEAB}}$ or $\overline{\text{LEBA}}$ low	3.3		3.3		3.3		3.3		ns
t_{su}	Setup time	A or B before $\overline{\text{LEAB}}$ or $\overline{\text{LEBA}}\uparrow$	Data high	0.4		0.4		0.4		0.4	ns
			Data low	1		1.5		1		1.5	
		A or B before $\overline{\text{CEAB}}$ or $\overline{\text{CEBA}}\uparrow$	Data high	0.2		0.2		0.2		0.2	
			Data low	0.7		1.2		0.7		1.2	
t_h	Hold time	A or B after $\overline{\text{LEAB}}$ or $\overline{\text{LEBA}}\uparrow$	Data high	1.5		0.6		1.5		0.6	ns
			Data low	1.3		1.5		1.3		1.5	
		A or B after $\overline{\text{CEAB}}$ or $\overline{\text{CEBA}}\uparrow$	Data high	1.6		0.5		1.6		0.5	
			Data low	1.4		1.6		1.4		1.6	

switching characteristics over recommended operating free-air temperature range, $C_L = 50\text{ pF}$ (unless otherwise noted) (see Figure 1)

PARAMETER	FROM (INPUT)	TO (OUTPUT)	SN54LVTH543				SN74LVTH543				UNIT	
			$V_{CC} = 3.3\text{ V} \pm 0.3\text{ V}$		$V_{CC} = 2.7\text{ V}$		$V_{CC} = 3.3\text{ V} \pm 0.3\text{ V}$			$V_{CC} = 2.7\text{ V}$		
			MIN	MAX	MIN	MAX	MIN	TYP†	MAX	MIN		MAX
t_{PLH}	A or B	B or A	1.2	3.9		4.5	1.3	2.5	3.7		4.3	ns
t_{PHL}			1.2	3.9		4.5	1.3	2.5	3.7		4.3	
t_{PLH}	$\overline{\text{LE}}$	A or B	1.2	5.1		6.1	1.3	2.9	4.7		5.9	ns
t_{PHL}			1.2	5.1		6.1	1.3	2.9	4.7		5.9	
t_{PZH}	$\overline{\text{OE}}$	A or B	1	5.1		6.4	1.1	2.9	4.9		6.2	ns
t_{PZL}			1	5.1		6.4	1.1	3.2	4.9		6.2	
t_{PHZ}	$\overline{\text{OE}}$	A or B	1.9	5.6		6.2	2	3.4	5.3		5.9	ns
t_{PLZ}			1.9	5.6		6.2	2	3.7	5.3		5.9	
t_{PZH}	$\overline{\text{CE}}$	A or B	1.2	5.5		7	1.3	3.2	5.3		6.8	ns
t_{PZL}			1.2	5.5		7	1.3	3.5	5.3		6.8	
t_{PHZ}	$\overline{\text{CE}}$	A or B	2.2	5.7		6.2	2.3	3.8	5.4		5.9	ns
t_{PLZ}			2.2	5.7		5.9	2.3	3.9	5.4		5.6	

† All typical values are at $V_{CC} = 3.3\text{ V}$, $T_A = 25^\circ\text{C}$.

PRODUCT PREVIEW information concerns products in the formative or design phase of development. Characteristic data and other specifications are design goals. Texas Instruments reserves the right to change or discontinue these products without notice.



SN54LVTH543, SN74LVTH543 3.3-V ABT OCTAL REGISTERED TRANSCEIVERS WITH 3-STATE OUTPUTS

SCBS704F – AUGUST 1997 – REVISED OCTOBER 2003

PARAMETER MEASUREMENT INFORMATION

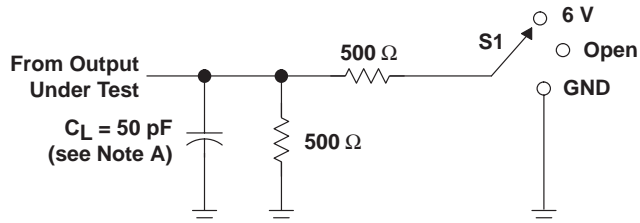

LOAD CIRCUIT

TEST	S1
t_{PLH}/t_{PHL}	Open
t_{PLZ}/t_{PZL}	6 V
t_{PHZ}/t_{PZH}	GND

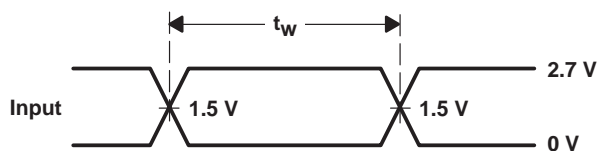

VOLTAGE WAVEFORMS
PULSE DURATION

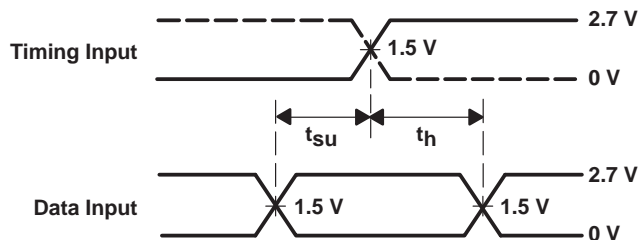

VOLTAGE WAVEFORMS
SETUP AND HOLD TIMES

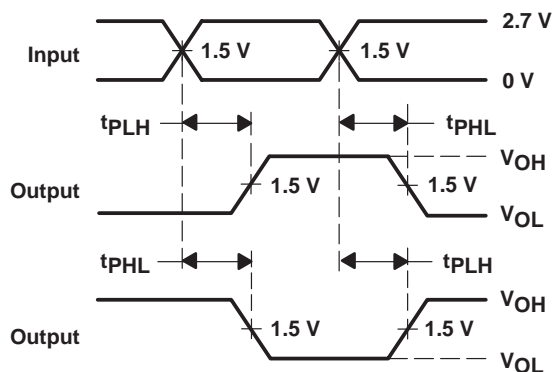

VOLTAGE WAVEFORMS
PROPAGATION DELAY TIMES
INVERTING AND NONINVERTING OUTPUTS

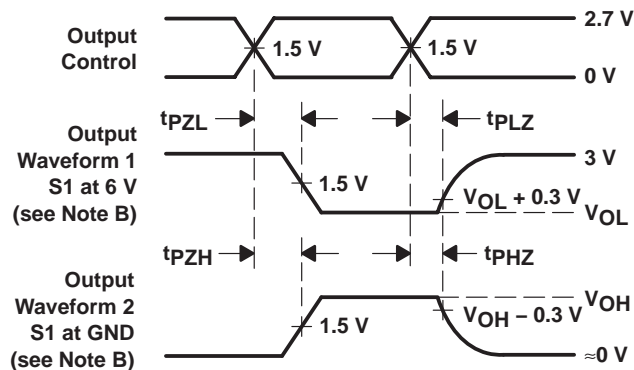

VOLTAGE WAVEFORMS
ENABLE AND DISABLE TIMES
LOW- AND HIGH-LEVEL ENABLING

- NOTES:
- C_L includes probe and jig capacitance.
 - Waveform 1 is for an output with internal conditions such that the output is low except when disabled by the output control. Waveform 2 is for an output with internal conditions such that the output is high except when disabled by the output control.
 - All input pulses are supplied by generators having the following characteristics: $PRR \leq 10 \text{ MHz}$, $Z_O = 50 \Omega$, $t_r \leq 2.5 \text{ ns}$, $t_f \leq 2.5 \text{ ns}$.
 - The outputs are measured one at a time with one transition per measurement.
 - All parameters and waveforms are not applicable to all devices.

Figure 1. Load Circuit and Voltage Waveforms

PACKAGING INFORMATION

Orderable Device	Status ⁽¹⁾	Package Type	Package Drawing	Pins	Package Qty	Eco Plan ⁽²⁾	Lead/Ball Finish	MSL Peak Temp ⁽³⁾
SN74LVTH543DBLE	OBSOLETE	SSOP	DB	24		TBD	Call TI	Call TI
SN74LVTH543DBR	ACTIVE	SSOP	DB	24	2000	Pb-Free (RoHS)	CU NIPDAU	Level-2-260C-1 YEAR/ Level-1-235C-UNLIM
SN74LVTH543DGVR	ACTIVE	TVSOP	DGV	24	2000	Pb-Free (RoHS)	CU NIPDAU	Level-1-250C-UNLIM
SN74LVTH543DW	ACTIVE	SOIC	DW	24	25	Pb-Free (RoHS)	CU NIPDAU	Level-2-250C-1 YEAR/ Level-1-235C-UNLIM
SN74LVTH543DWR	ACTIVE	SOIC	DW	24	2000	Pb-Free (RoHS)	CU NIPDAU	Level-2-250C-1 YEAR/ Level-1-235C-UNLIM
SN74LVTH543NSR	ACTIVE	SO	NS	24	2000	Pb-Free (RoHS)	CU NIPDAU	Level-2-260C-1 YEAR/ Level-1-235C-UNLIM
SN74LVTH543PW	ACTIVE	TSSOP	PW	24	60	Pb-Free (RoHS)	CU NIPDAU	Level-1-250C-UNLIM
SN74LVTH543PWLE	OBSOLETE	TSSOP	PW	24		TBD	Call TI	Call TI
SN74LVTH543PWR	ACTIVE	TSSOP	PW	24	2000	Pb-Free (RoHS)	CU NIPDAU	Level-1-250C-UNLIM

⁽¹⁾ The marketing status values are defined as follows:

ACTIVE: Product device recommended for new designs.

LIFEBUY: TI has announced that the device will be discontinued, and a lifetime-buy period is in effect.

NRND: Not recommended for new designs. Device is in production to support existing customers, but TI does not recommend using this part in a new design.

PREVIEW: Device has been announced but is not in production. Samples may or may not be available.

OBSOLETE: TI has discontinued the production of the device.

⁽²⁾ Eco Plan - The planned eco-friendly classification: Pb-Free (RoHS) or Green (RoHS & no Sb/Br) - please check <http://www.ti.com/productcontent> for the latest availability information and additional product content details.

TBD: The Pb-Free/Green conversion plan has not been defined.

Pb-Free (RoHS): TI's terms "Lead-Free" or "Pb-Free" mean semiconductor products that are compatible with the current RoHS requirements for all 6 substances, including the requirement that lead not exceed 0.1% by weight in homogeneous materials. Where designed to be soldered at high temperatures, TI Pb-Free products are suitable for use in specified lead-free processes.

Green (RoHS & no Sb/Br): TI defines "Green" to mean Pb-Free (RoHS compatible), and free of Bromine (Br) and Antimony (Sb) based flame retardants (Br or Sb do not exceed 0.1% by weight in homogeneous material)

⁽³⁾ MSL, Peak Temp. -- The Moisture Sensitivity Level rating according to the JEDEC industry standard classifications, and peak solder temperature.

Important Information and Disclaimer:The information provided on this page represents TI's knowledge and belief as of the date that it is provided. TI bases its knowledge and belief on information provided by third parties, and makes no representation or warranty as to the accuracy of such information. Efforts are underway to better integrate information from third parties. TI has taken and continues to take reasonable steps to provide representative and accurate information but may not have conducted destructive testing or chemical analysis on incoming materials and chemicals. TI and TI suppliers consider certain information to be proprietary, and thus CAS numbers and other limited information may not be available for release.

In no event shall TI's liability arising out of such information exceed the total purchase price of the TI part(s) at issue in this document sold by TI to Customer on an annual basis.

DGV (R-PDSO-G**)

PLASTIC SMALL-OUTLINE

24 PINS SHOWN



- NOTES: A. All linear dimensions are in millimeters.
 B. This drawing is subject to change without notice.
 C. Body dimensions do not include mold flash or protrusion, not to exceed 0,15 per side.
 D. Falls within JEDEC: 24/48 Pins – MO-153
 14/16/20/56 Pins – MO-194

DW (R-PDSO-G24)

PLASTIC SMALL-OUTLINE PACKAGE

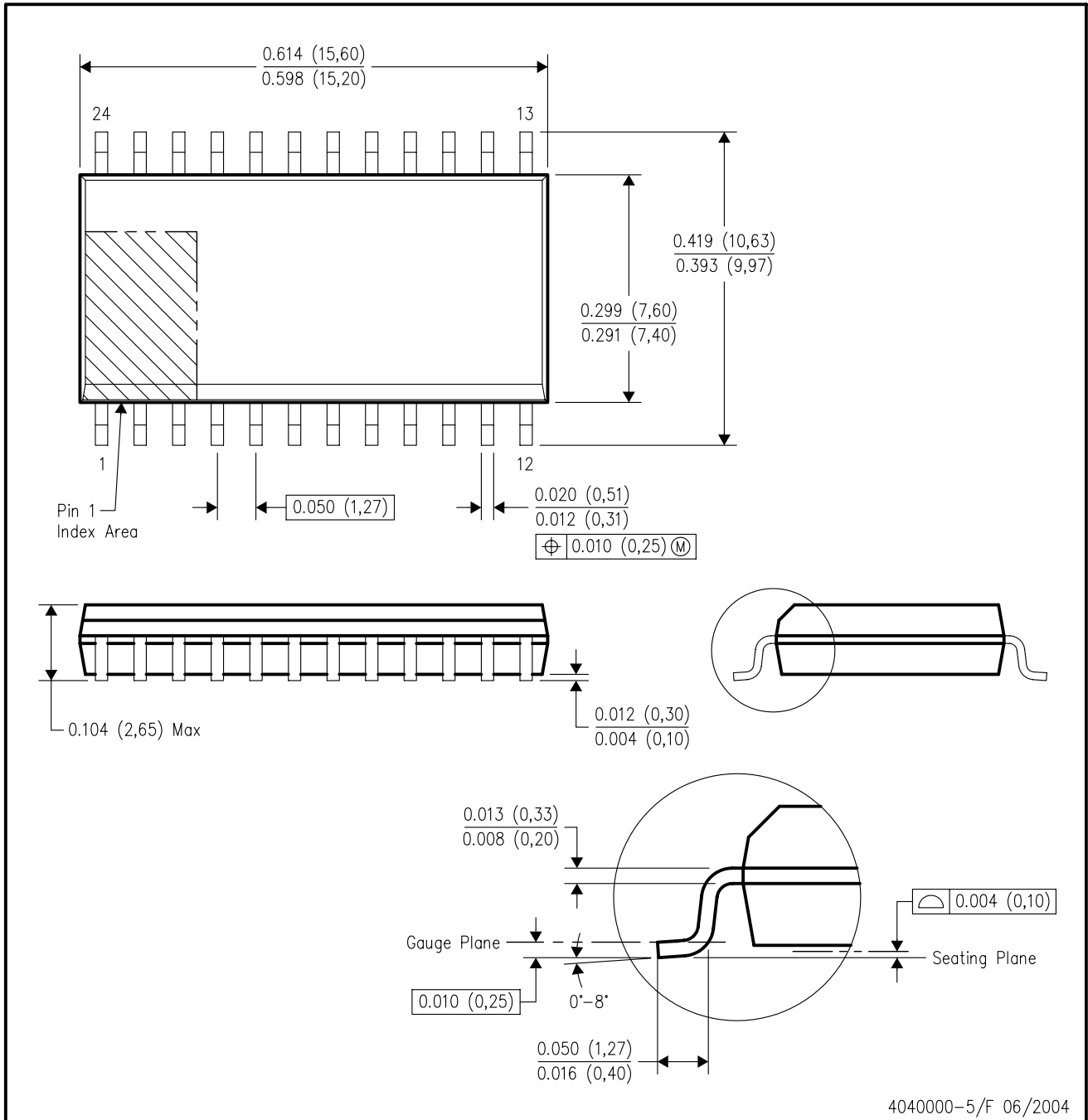

- NOTES:
- A. All linear dimensions are in inches (millimeters).
 - B. This drawing is subject to change without notice.
 - C. Body dimensions do not include mold flash or protrusion not to exceed 0.006 (0,15).
 - D. Falls within JEDEC MS-013 variation AD.

MECHANICAL DATA

NS (R-PDSO-G**)

PLASTIC SMALL-OUTLINE PACKAGE

14-PINS SHOWN



- NOTES:
- A. All linear dimensions are in millimeters.
 - B. This drawing is subject to change without notice.
 - C. Body dimensions do not include mold flash or protrusion, not to exceed 0,15.

DB (R-PDSO-G**)

PLASTIC SMALL-OUTLINE

28 PINS SHOWN



- NOTES: A. All linear dimensions are in millimeters.
 B. This drawing is subject to change without notice.
 C. Body dimensions do not include mold flash or protrusion not to exceed 0,15.
 D. Falls within JEDEC MO-150

PW (R-PDSO-G**)

PLASTIC SMALL-OUTLINE PACKAGE

14 PINS SHOWN



- NOTES: A. All linear dimensions are in millimeters.
 B. This drawing is subject to change without notice.
 C. Body dimensions do not include mold flash or protrusion not to exceed 0,15.
 D. Falls within JEDEC MO-153

IMPORTANT NOTICE

Texas Instruments Incorporated and its subsidiaries (TI) reserve the right to make corrections, modifications, enhancements, improvements, and other changes to its products and services at any time and to discontinue any product or service without notice. Customers should obtain the latest relevant information before placing orders and should verify that such information is current and complete. All products are sold subject to TI's terms and conditions of sale supplied at the time of order acknowledgment.

TI warrants performance of its hardware products to the specifications applicable at the time of sale in accordance with TI's standard warranty. Testing and other quality control techniques are used to the extent TI deems necessary to support this warranty. Except where mandated by government requirements, testing of all parameters of each product is not necessarily performed.

TI assumes no liability for applications assistance or customer product design. Customers are responsible for their products and applications using TI components. To minimize the risks associated with customer products and applications, customers should provide adequate design and operating safeguards.

TI does not warrant or represent that any license, either express or implied, is granted under any TI patent right, copyright, mask work right, or other TI intellectual property right relating to any combination, machine, or process in which TI products or services are used. Information published by TI regarding third-party products or services does not constitute a license from TI to use such products or services or a warranty or endorsement thereof. Use of such information may require a license from a third party under the patents or other intellectual property of the third party, or a license from TI under the patents or other intellectual property of TI.

Reproduction of information in TI data books or data sheets is permissible only if reproduction is without alteration and is accompanied by all associated warranties, conditions, limitations, and notices. Reproduction of this information with alteration is an unfair and deceptive business practice. TI is not responsible or liable for such altered documentation.

Resale of TI products or services with statements different from or beyond the parameters stated by TI for that product or service voids all express and any implied warranties for the associated TI product or service and is an unfair and deceptive business practice. TI is not responsible or liable for any such statements.

Following are URLs where you can obtain information on other Texas Instruments products and application solutions:

Products		Applications	
Amplifiers	amplifier.ti.com	Audio	www.ti.com/audio
Data Converters	dataconverter.ti.com	Automotive	www.ti.com/automotive
DSP	dsp.ti.com	Broadband	www.ti.com/broadband
Interface	interface.ti.com	Digital Control	www.ti.com/digitalcontrol
Logic	logic.ti.com	Military	www.ti.com/military
Power Mgmt	power.ti.com	Optical Networking	www.ti.com/opticalnetwork
Microcontrollers	microcontroller.ti.com	Security	www.ti.com/security
		Telephony	www.ti.com/telephony
		Video & Imaging	www.ti.com/video
		Wireless	www.ti.com/wireless

Mailing Address: Texas Instruments
Post Office Box 655303 Dallas, Texas 75265