



75T204

5V Low-Power Subscriber DTMF Receiver

April 2000

DESCRIPTION

The 75T204 is a complete Dual-Tone Multifrequency (DTMF) receiver that detects 16 standard digits. No front-end pre-filtering is needed. The only external components required are an inexpensive 3.58-MHz television "colorburst" crystal for frequency reference and a bias resistor. An Alternate Time Base (ATB) is provided to permit operation of up to 10 75T204's from a single crystal. The 75T204 employs state-of-the-art "switched-capacitor" filter technology, resulting in approximately 40 poles of filtering, and digital circuitry on the same CMOS chip. The analog input signal is pre-processed by 60-Hz reject and band split filters and then zero-cross detected to provide AGC. Eight bandpass filters detect the individual tones. Digital processing is used to measure the tone and pause durations

(continued)

FEATURES

- Intended for applications with less requirements than the 75T202/75T203
- 14-pin plastic DIP or 16-pin SO package for high system density
- NO front-end band-splitting filters required
- Single low-tolerance 5-volt supply
- Detects all 16 standard DTMF digits.
- Uses an inexpensive 3.579545-MHz crystal
- Excellent speech immunity
- Output in 4-bit hexadecimal code
- Three-state outputs for microprocessor interface

BLOCK DIAGRAM

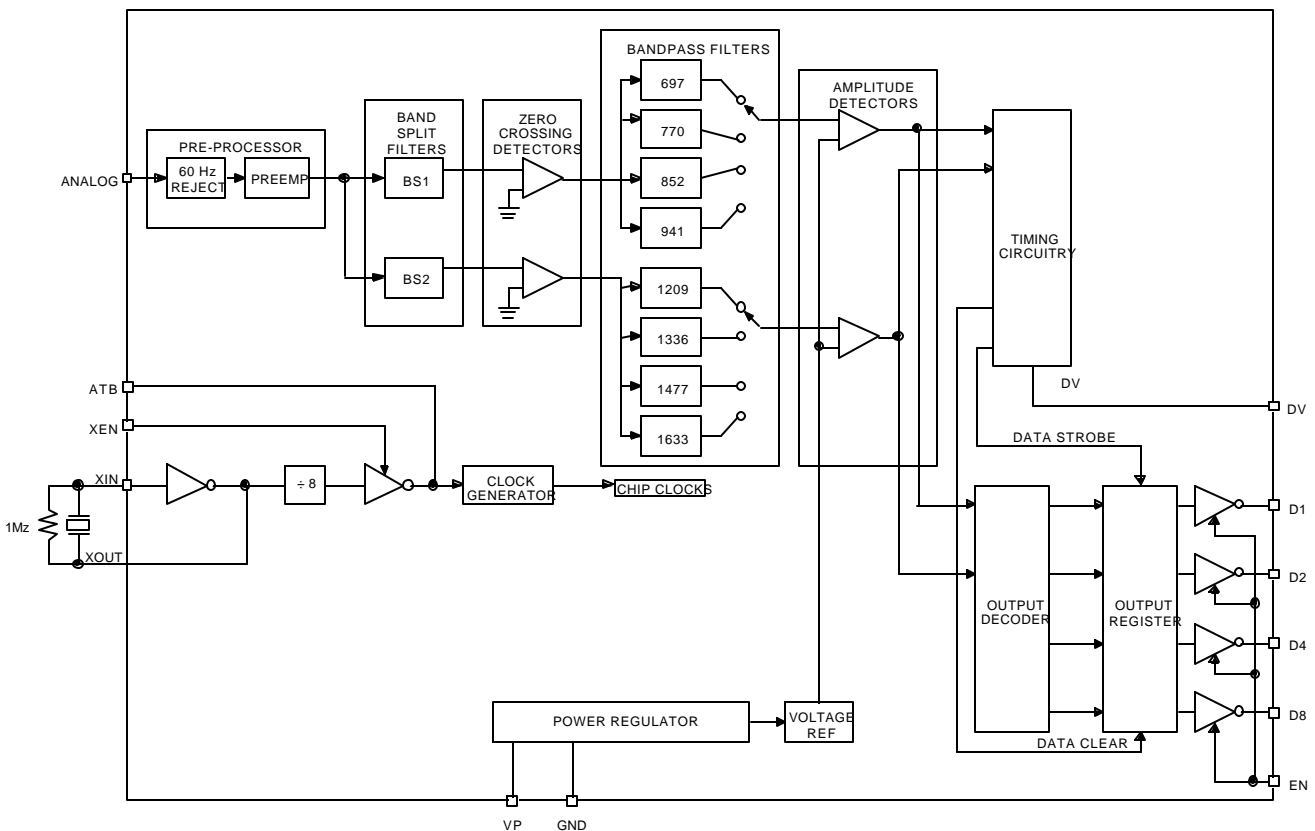

75T204

5V Low-Power Subscriber DTMF Receiver

DESCRIPTION (continued)

and to provide output timing and decoding. The outputs interface directly to standard CMOS circuitry and are three-state enabled to facilitate bus-oriented architectures.

ANALOG IN

This pin accepts the analog input. It is internally biased so that the input signal may be AC coupled. The input may be DC coupled as long as it does not exceed the positive supply. Proper input coupling is illustrated in Figure 1.

The 75T204 is designed to accept sinusoidal input wave forms but will operate satisfactorily with any input that has the correct fundamental frequency with harmonics less than -20 dB below the fundamental.

CRYSTAL OSCILLATOR

The 75T204 contains an onboard inverter with sufficient gain to provide oscillation when connected to a low-cost television “colorburst” crystal. The crystal oscillator is enabled by tying XEN high. The crystal is connected between XIN and XOUT. A 1 M Ω 10% resistor is also connected between these pins. In this mode, ATB is a clock frequency output. Other 75T204’s (or 75T202’s) may use the same frequency reference by tying their ATB pins to the ATB of a crystal connected device. XIN and XEN of the auxiliary devices must then be tied high and low respectively. Ten devices may run off a single crystal-connected 75T204 (or 75T202) as shown in Figure 2.

OUTPUTS D1, D2, D4, D8 and EN

Outputs D1, D2, D4, D8 are CMOS push-pull when enabled (EN high) and open circuited (high impedance) when disabled by pulling EN low. These digital outputs provide the hexadecimal code corresponding to the detected digit. The digital outputs become valid after a tone pair has been detected (DV is high) and they are then cleared when a valid pause is timed. The hexadecimal codes are described in Table 1.

DV

DV signals a detection by going high after a valid tone pair is sensed and decoded at the output pins D1, D2, D4, and D8. DV remains high until a valid pause occurs.

N/C PINS

These pins have no internal connection and may be left floating.

Output Code				
Digit	D8	D4	D2	D1
1	0	0	0	1
2	0	0	1	0
3	0	0	1	1
4	0	1	0	0
5	0	1	0	1
6	0	1	1	0
7	0	1	1	1
8	1	0	0	0
9	1	0	0	1
0	1	0	1	0
*	1	0	1	1
#	1	1	0	0
A	1	1	0	1
B	1	1	1	0
C	1	1	1	1
D	0	0	0	0

TABLE 1: Output Codes

75T204 5V Low-Power Subscriber DTMF Receiver

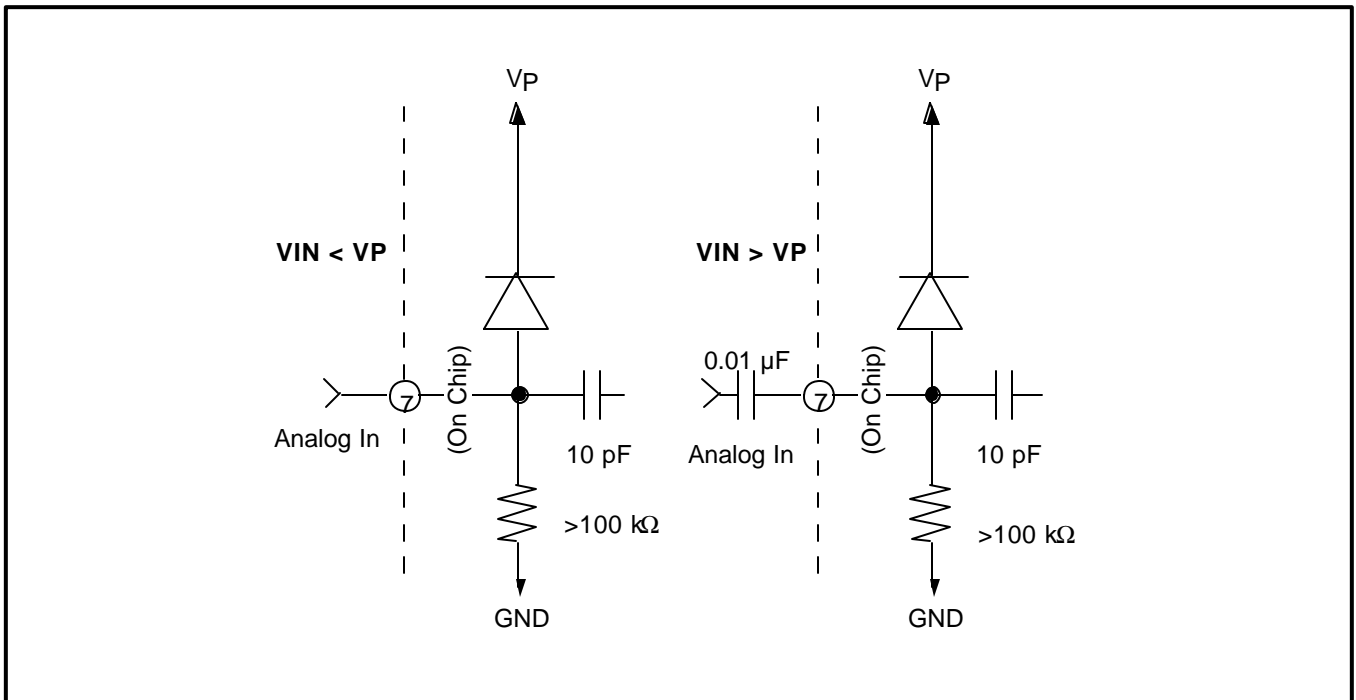

FIGURE 1: Input Coupling

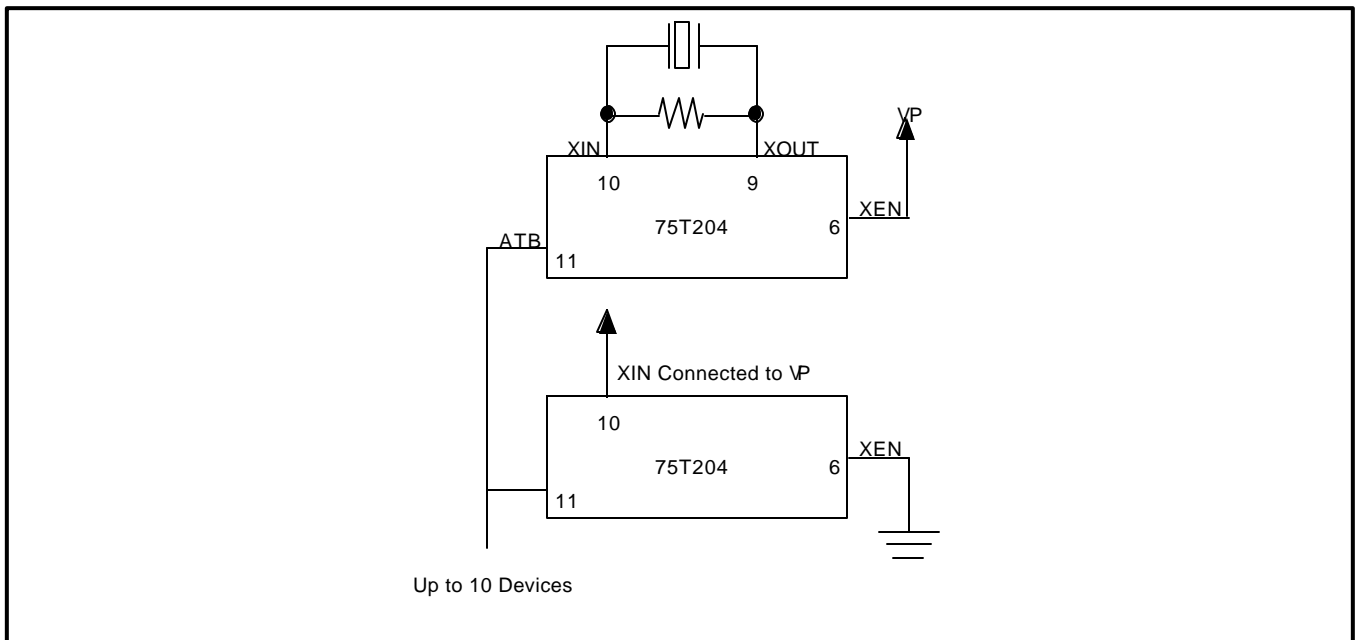

FIGURE 2: Crystal Connections

75T204

5V Low-Power Subscriber DTMF Receiver

DTMF DIALING MATRIX

See Figure 3. Please note that column 3 is for special applications and is not normally used in telephone dialing.

	Col 0	Col 1	Col 2	Col 3
Row 0	1	2	3	A
Row 1	4	5	6	B
Row 2	7	8	9	C
Row 3	*	0	#	D

FIGURE 3: DTMF Dialing Matrix

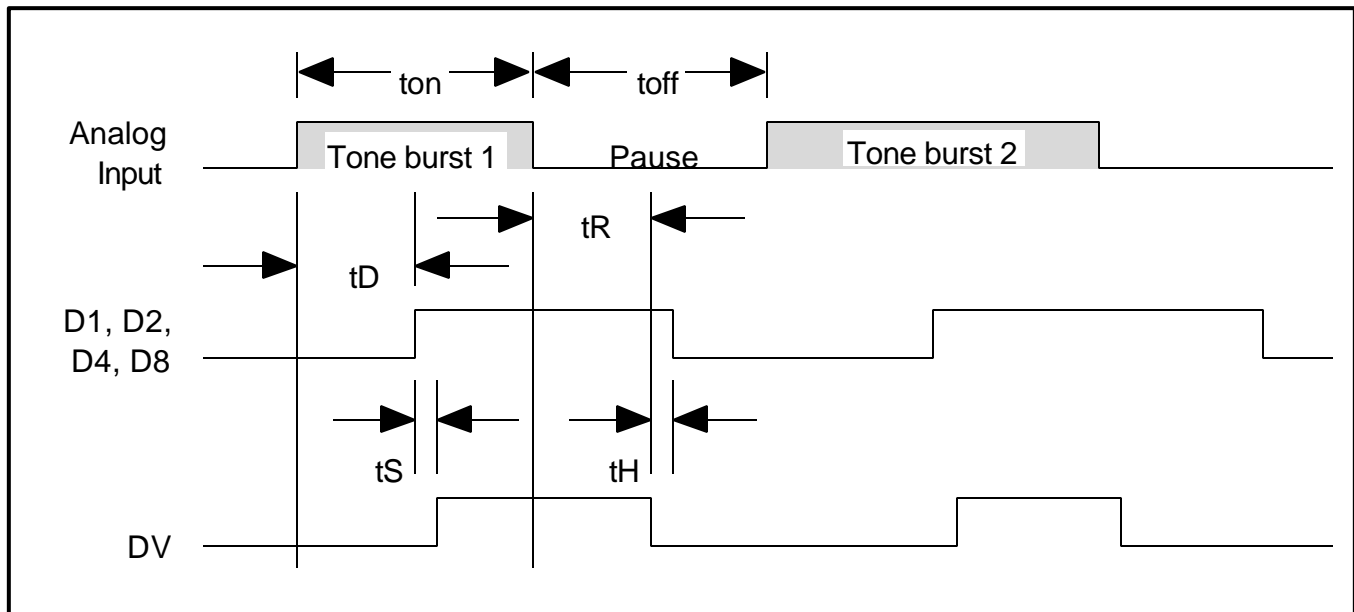

FIGURE 4: Timing Diagram

75T204

5V Low-Power Subscriber DTMF Receiver

DETECTION FREQUENCY

Low Group f_0	High Group f_0
Row 0 = 697 Hz	Column 0 = 1209 Hz
Row 1 = 770 Hz	Column 1 = 1336 Hz
Row 2 = 852 Hz	Column 2 = 1477 Hz
Row 3 = 941 Hz	Column 3 = 1633 Hz

75T204 TIMING (Refer to Figure 4.)

PARAMETER	CONDITIONS	MIN	NOM	MAX	UNITS	
tON Tone Time	for detection	40	-	-	ms	
	for rejection	-	-	20	ms	
tOFF Pause Time	for detection	40	-	-	ms	
	for rejection	-	-	20	ms	
tD Detect Time		25	-	46	ms	
tR Release Time		35	-	50	ms	
tSU Data Setup Time		7	-	-	μ s	
tH Data Hold Time		4.2	-	5.0	ms	
	Output Enable Time	$C_L = 50\text{pF}$, $R_L = 1\text{k}\frac{1}{2}$	-	-	200	ns
	Output Disable Time	$C_L = 35\text{pF}$, $R_L = 500\frac{1}{2}$	-	-	200	ns
	Output Rise Time	$C_L = 50\text{pF}$	-	-	200	ns
	Output Fall Time	$C_L = 50\text{pF}$	-	-	200	ns

75T204

5V Low-Power Subscriber DTMF Receiver

APPLICATION INFORMATION

The 75T204 will tolerate total input RMS noise up to 12dB below the lowest amplitude tone. For most telephone applications, the combination of the high frequency attenuation of the telephone line and internal band-limiting make special circuitry at the input to the 75T204 unnecessary. However, noise near the 56kHz internal sampling frequency will be aliased (folded back) into the audio spectrum, so if

excessive noise is present above 28kHz, the simple RC filter shown in Figure 5 may be employed to band limit the incoming signal.

Noise will also be reduced by placing a grounded trace around the XIN and XOUT pins on the circuit board layout when using a crystal. It is important to note that XOUT is not intended to drive an additional device. XIN may be driven externally; in this case leave XOUT floating.

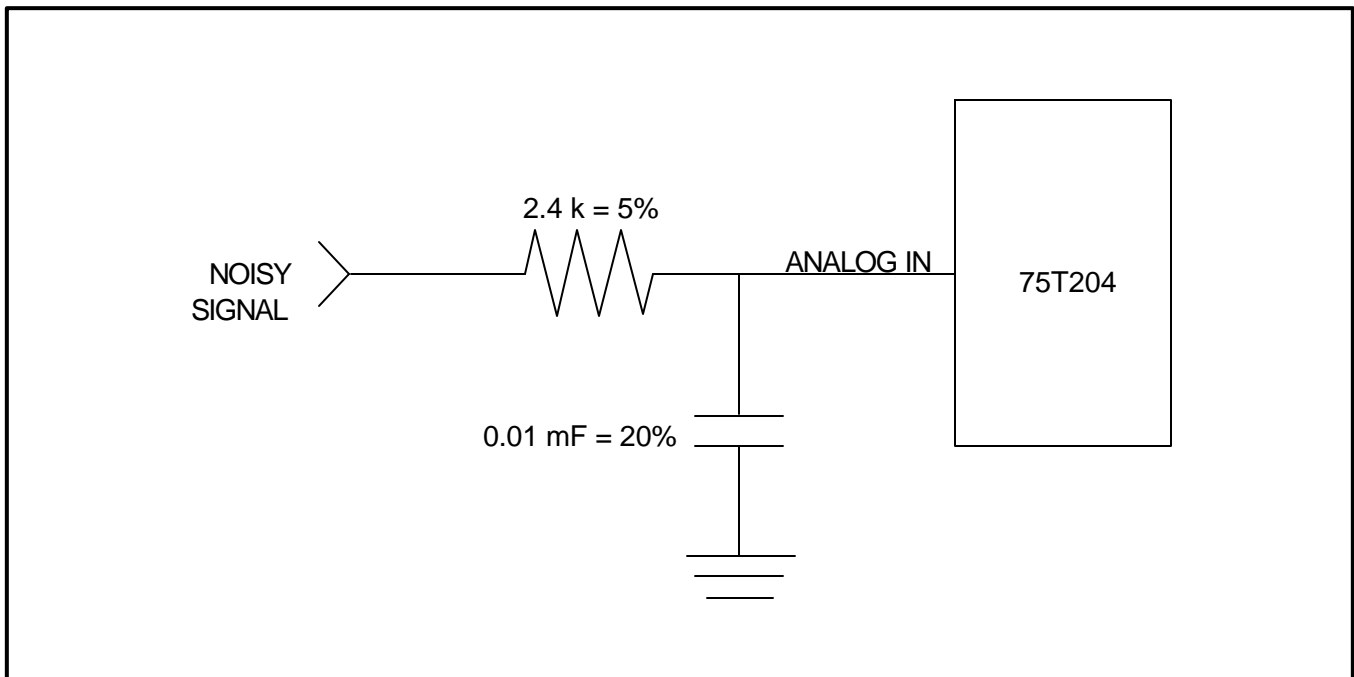

FIGURE 5: RC Filter

75T204

5V Low-Power Subscriber DTMF Receiver

ELECTRICAL SPECIFICATIONS

ABSOLUTE MAXIMUM RATINGS

(Operation above absolute maximum ratings may damage the device. All 75T204 unused inputs must be connected to VP or GND, as appropriate.)

PARAMETER	RATING
DC Supply Voltage - VP	+7V
Operating Temperature	-40°C to +85°C Ambient
Storage Temperature	-65°C to +150°C
Power Dissipation (25°C)	65mW
Input Voltage (All inputs except ANALOG IN)	(VP + 0.5V) to -0.5V
ANALOG IN Voltage	(VP + .5V) to (VP - 10V)
DC Current into any Input	±1.0mA
Lead Temperature - Soldering, 10 sec.	300°C

ELECTRICAL CHARACTERISTICS

(-40°C ≤ TA ≤ +85°C, VP = 5V ± 10%)

PARAMETER	CONDITIONS	MIN	TYP	MAX	UNITS
Frequency Detect Bandwidth		±(1.5+2Hz)	±2.3	±3.5	% of fo
Amplitude for Detection	each tone	-32		-2	dBm ref. to 600Ω
Twist Tolerance	$Twist = \frac{High\ Tone}{Low\ Tone}$	-10		+10	dB
60-Hz Tolerance				0.8	Vrms
Dial Tone Tolerance	"precise" dial tone			0dB	dB*
Talk Off	MITEL tape #CM 7290		2		hits
Digital Outputs	"0" level, 400μA load	0		0.5	V
(except XOUT)	"1" level, 200μA load	VP-0.5		VP	V
Digital Inputs	"0" level	0		0.3VP	V
	"1" level	0.7VP		VP	V
Power Supply Noise	wide band			10	mV p-p
Supply Current	TA = 25°C		10	16	mA
Noise Tolerance	MITEL tape #CM 7290			-12	dB*
Input Impedance	VP ³ V IN ³ V P-10	100KΩ 15pF			

* dB referenced to lowest amplitude tone

75T204

5V Low-Power Subscriber DTMF Receiver

MECHANICAL SPECIFICATIONS

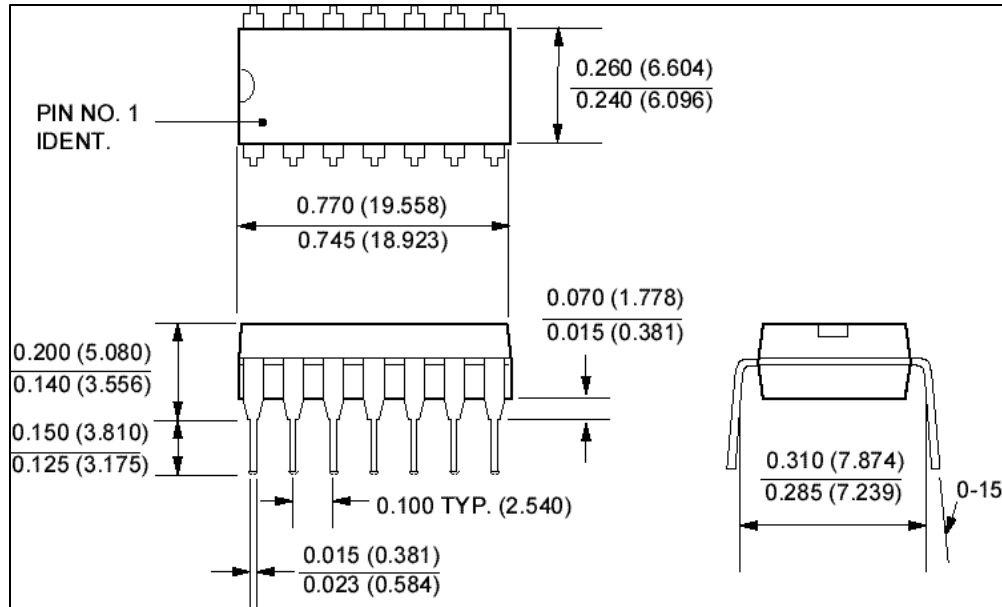

14-Pin DIP

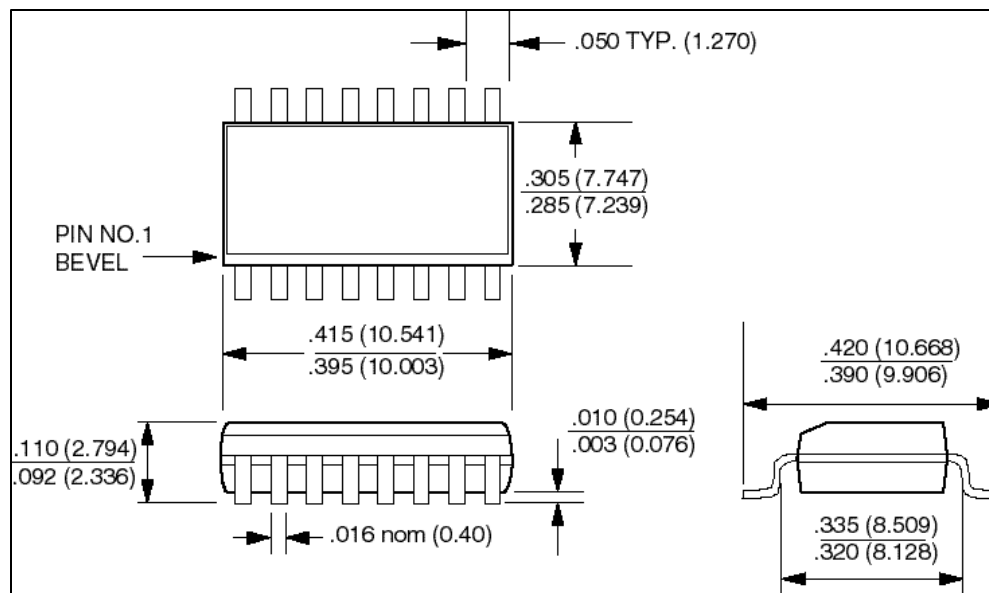

16-Pin SOL

75T204

5V Low-Power Subscriber DTMF Receiver

PACKAGE PIN DESIGNATIONS (Top View)

CAUTION: Use handling procedures necessary for a static sensitive component.

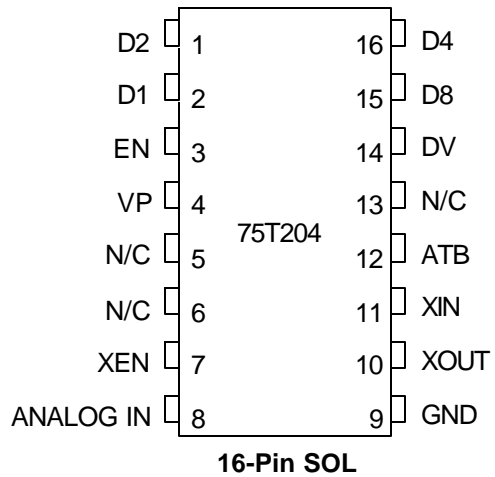
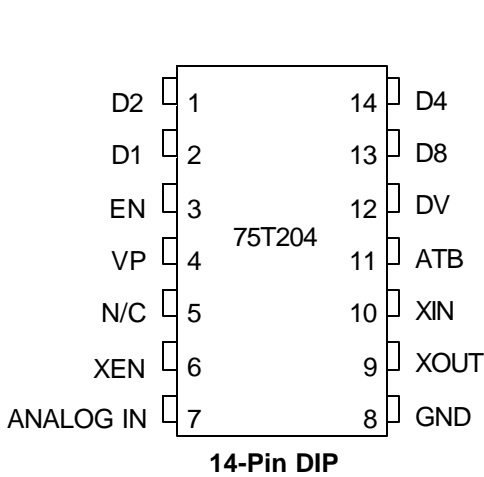

ORDERING INFORMATION

PART DESCRIPTION	ORDER NUMBER	PACKAGING MARK
75T204 14-Pin PDIP	75T204-IP	75T204-IP
75T204 16-SOL	75T204-IL	75T204-IL

No responsibility is assumed by TDK Semiconductor Corporation for use of this product nor for any infringements of patents and trademarks or other rights of third parties resulting from its use. No license is granted under any patents, patent rights or trademarks of TDK Semiconductor Corporation and the company reserves the right to make changes in specifications at any time without notice. Accordingly, the reader is cautioned to verify that the data sheet is current before placing orders.

TDK Semiconductor Corporation, 2642 Michelle Drive, Tustin, CA 92780-7019, (714) 508-8800, FAX: (714) 508-8877