

Features

- complies with ANSI and ETSI requirements
- matched to Globespan's DMT G7000, EL-1501, G7266 and G7266RT chipsets
- very low THD
- 1500V minimum isolation
- all materials approved to UL94V-0
- excellent quality at competitive price due to high volume production
- manufactured in ISO-9001 approved TALEMA facility

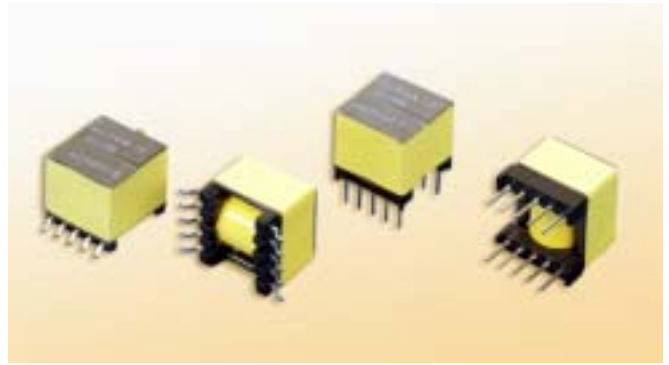

Electrical Specifications @ 25°C • Operating Temperature -40° to +85°C

Part Number	Package	IC Driver	Turns Ratio ±2% Line : IC	L _p (μH)	L _L (μH) Max	C _{WW} (pF) Max	DCR (Ohms) Max Line / IC	THD (Linearity) Typical	Longitudinal Balance Min	Insertion Loss Max	Freq. Response Max	Isolation Voltage (Vrms)
AEP500-S	SMD	G7000 CPE	2 : 1	435 ±6%	10	40	1.30 / 1.50	-80dB 100kHz	-40dB 20kHz-1.1MHz	0.5dB 722kHz	0.5dB 30kHz-1.1MHz	1500
AEP510-T	TH	G7000 CO	1.4 : 1	441 ±6%	6	40	1.05 / 0.85	-70dB 200kHz	-60dB 20kHz-1.1MHz	0.5dB 722kHz	1.0dB 150kHz-1.5MHz	
AEP510-S	SMD											
AEP520-T	TH	EL-1501 CPE	1 : 1	407 ±6%	10	40	1.40 / 1.20	-85dB 100kHz	-50dB 30kHz-1.1MHz	0.5dB 722kHz	3.0dB 30kHz-2.0MHz	
AEP520-S	SMD											
AEP530-T	TH	EL-1501 CPE	1 : 1	407 ±6%	10	40	1.40 / 1.20	-85dB 100kHz	-50dB 30kHz-1.1MHz	0.5dB 722kHz	3.0dB 30kHz-2.0MHz	
AEP530-S	SMD											
AEP540-T	TH	EL-1501 CO	1 : 1.4	483 ±10%	10	50	1.30 / 2.45	-85dB 100kHz	-50dB 30kHz-1.1MHz	0.5dB 722kHz	3.0dB 30kHz-2.0MHz	
AEP540-S	SMD											
AEP550-T	TH	G7266 CO	1.41 : 1	474 ±10%	12	40	1.10 / 0.85	-80dB 100kHz	-50dB 30kHz-1.1MHz	1.0dB 722kHz	0.5dB 100kHz-1.1MHz	
AEP550-S	SMD											
AEP560-S	SMD	G7266RT	2 : 1	440 ±5%	6	40	1.90 / 0.95	-80dB 100kHz	-50dB 30kHz-1.1MHz	1.0dB 722kHz	0.5dB 100kHz-1.1MHz	

Package "S"

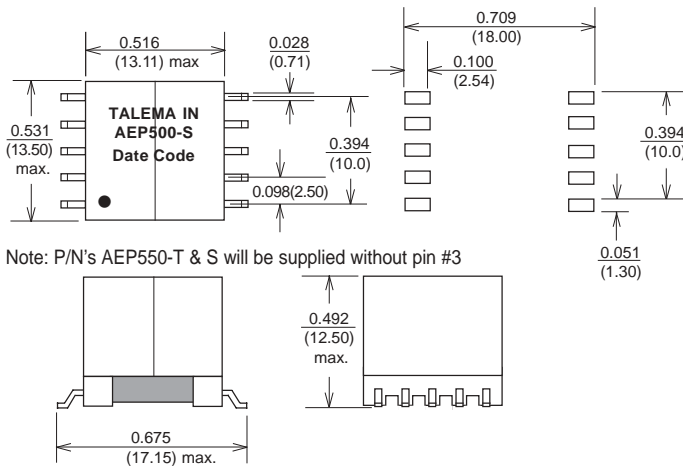

Package "T"

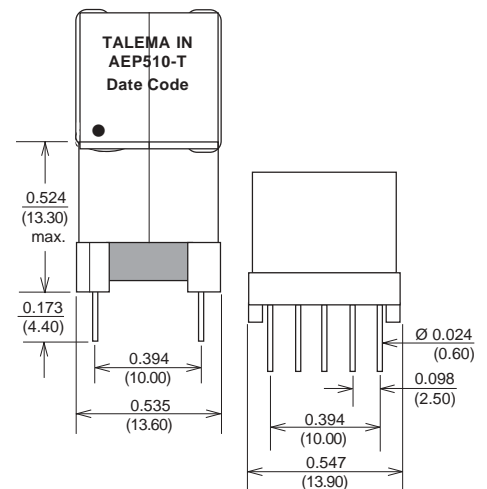

Schematic

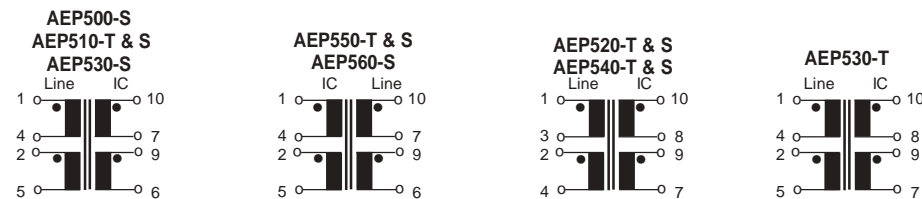

Dimensions: Inches (Millimeters)
Tolerance: ±0.010 (0.25)

Weight: 6.8 grams