



TDA7439DS

THREE BANDS DIGITALLY CONTROLLED AUDIO PROCESSOR

- INPUT MULTIPLEXER
 - 4 STEREO INPUTS
 - SELECTABLE INPUT GAIN FOR OPTIMAL ADAPTATION TO DIFFERENT SOURCES
- ONE STEREO OUTPUT
- TREBLE, MIDDLE AND BASS CONTROL IN 2.0dB STEPS
- VOLUME CONTROL IN 1.0dB STEPS
- TWO SPEAKER ATTENUATORS:
 - TWO INDEPENDENT SPEAKER CONTROL IN 1.0dB STEPS FOR BALANCE FACILITY
 - INDEPENDENT MUTE FUNCTION
- ALL FUNCTION ARE PROGRAMMABLE VIA SERIAL BUS



DESCRIPTION

The TDA7439DS is a volume tone (bass, middle and treble) balance (Left/Right) processor for quality audio applications in car-radio and Hi-Fi systems.

Selectable input gain is provided. Control of all

the functions is accomplished by serial bus.

The AC signal setting is obtained by resistor networks and switches combined with operational amplifiers.

Thanks to the used BIPOLAR/CMOS Technology, Low Distortion, Low Noise and DC stepping are obtained

BLOCK DIAGRAM

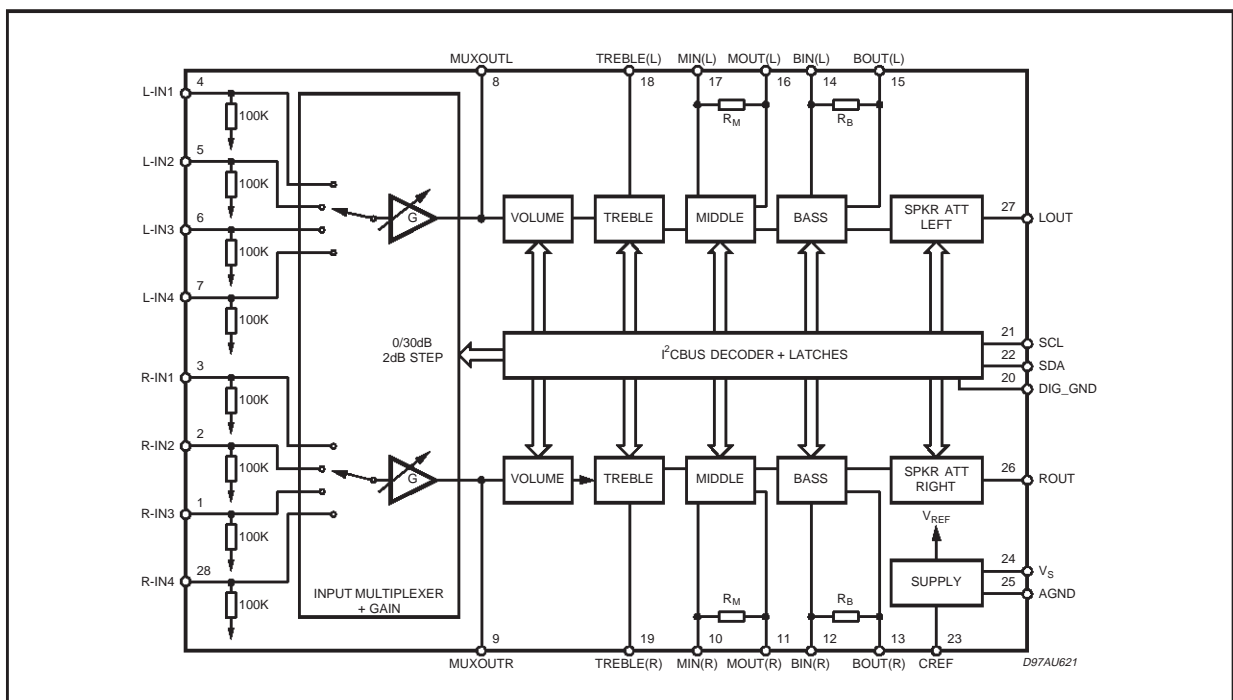

TDA7439DS

ABSOLUTE MAXIMUM RATINGS

Symbol	Parameter	Value	Unit
V_S	Operating Supply Voltage	10.5	V
T_{amb}	Operating Ambient Temperature	-10 to 85	°C
T_{stg}	Storage Temperature Range	-55 to 150	°C

PIN CONNECTION

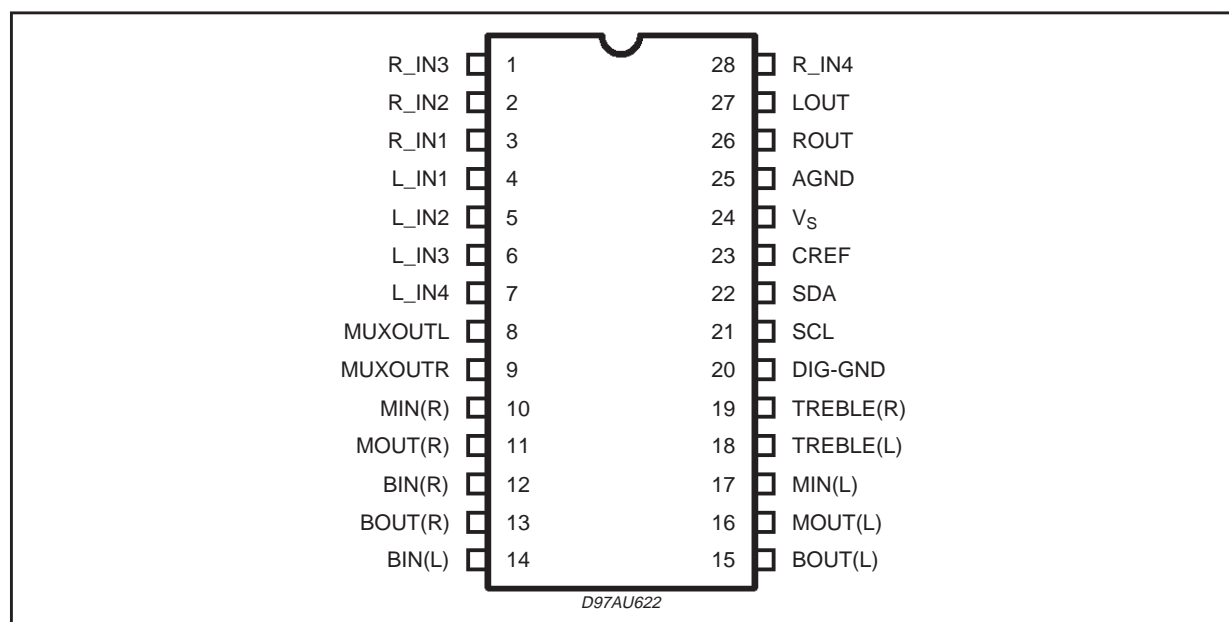

THERMAL DATA

Symbol	Parameter	Value	Unit
$R_{th\ j-pin}$	Thermal Resistance Junction-pins	85	°C/W

QUICK REFERENCE DATA

Symbol	Parameter	Min.	Typ.	Max.	Unit
V_S	Supply Voltage	7	9	10.2	V
V_{CL}	Max. input signal handling	2			V _{rms}
THD	Total Harmonic Distortion $V = 1V_{rms}$ $f = 1KHz$		0.01	0.1	%
S/N	Signal to Noise Ratio $V_{out} = 1V_{rms}$ (mode = OFF)		106		dB
S_C	Channel Separation $f = 1KHz$		90		dB
	Input Gain in (2dB step)	0		30	dB
	Volume Control (1dB step)	-47		0	dB
	Treble Control (2dB step)	-14		+14	dB
	Middle Control (2dB step)	-14		+14	dB
	Bass Control (2dB step)	-14		+14	dB
	Balance Control 1dB step	-79		0	dB
	Mute Attenuation		100		dB

ELECTRICAL CHARACTERISTICS (refer to the test circuit $T_{amb} = 25^{\circ}\text{C}$, $V_S = 9\text{V}$, $R_L = 10\text{K}\Omega$, $R_G = 600\Omega$, all controls flat ($G = 0\text{dB}$), unless otherwise specified)

Symbol	Parameter	Test Condition	Min.	Typ.	Max.	Unit
SUPPLY						
V_S	Supply Voltage		7	9	10.2	V
I_S	Supply Current		4	7	10	mA
SVR	Ripple Rejection		60	90		dB
INPUT STAGE						
R_{IN}	Input Resistance		70	100	130	$\text{K}\Omega$
V_{CL}	Clipping Level	THD = 0.3%	2	2.5		V _{rms}
S_{IN}	Input Separation	The selected input is grounded through a 2.2 μ capacitor	80	100		dB
G_{inmin}	Minimum Input Gain		-1	0	1	dB
G_{inmax}	Maximum Input Gain		29	30	31	dB
G_{step}	Step Resolution		1.5	2	2.5	dB
VOLUME CONTROL						
R_i	Input Resistance		20	33	50	$\text{K}\Omega$
C_{RANGE}	Control Range		45	47	49	dB
A_{VMAX}	Max. Attenuation		45	47	49	dB
A_{STEP}	Step Resolution		0.5	1	1.5	dB
E_A	Attenuation Set Error	$A_V = 0$ to -24dB	-1.0	0	1.0	dB
		$A_V = -24$ to -47dB	-1.5	0	1.5	dB
E_T	Tracking Error	$A_V = 0$ to -24dB		0	1	dB
		$A_V = -24$ to -47dB		0	2	dB
V_{DC}	DC Step	adjacent attenuation steps from 0dB to A_V max		0 0.5	3	mV mV
A_{mute}	Mute Attenuation		80	100		dB
BASS CONTROL (1)						
G_b	Control Range	Max. Boost/cut	± 12.0	± 14.0	± 16.0	dB
B_{STEP}	Step Resolution		1	2	3	dB
R_B	Internal Feedback Resistance		33	44	55	$\text{K}\Omega$
TREBLE CONTROL (1)						
G_t	Control Range	Max. Boost/cut	± 13.0	± 14.0	± 15.0	dB
T_{STEP}	Step Resolution		1	2	3	dB
MIDDLE CONTROL (1)						
G_m	Control Range	Max. Boost/cut	± 12.0	± 14.0	± 16.0	dB
M_{STEP}	Step Resolution		1	2	3	dB
R_M	Internal Feedback Resistance		18.75	25	31.25	$\text{K}\Omega$
SPEAKER ATTENUATORS						
C_{RANGE}	Control Range		70	76	82	dB
S_{STEP}	Step Resolution		0.5	1	1.5	dB
E_A	Attenuation Set Error	$A_V = 0$ to -20dB	-1.5	0	1.5	dB
		$A_V = -20$ to -56dB	-2	0	2	dB
V_{DC}	DC Step	adjacent attenuation steps		0	3	mV
A_{mute}	Mute Attenuation		80	100		dB

NOTE1:

- The device is functionally good at $V_S = 5\text{V}$. a step down, on V_S , to 4V does't reset the device.
- BASS, MIDDLE and TREBLE response: The center frequency and the response quality can be chosen by the external circuitry.

TDA7439DS

ELECTRICAL CHARACTERISTICS (continued.)

Symbol	Parameter	Test Condition	Min.	Typ.	Max.	Unit
AUDIO OUTPUTS						
V _{CLIP}	Clipping Level	d = 0.3%	2.1	2.6		V _{RMS}
R _L	Output Load Resistance		2			KΩ
R _O	Output Impedance		10	40	70	Ω
V _{DC}	DC Voltage Level		3.5	3.8	4.1	V
GENERAL						
E _{NO}	Output Noise	All gains = 0dB; BW = 20Hz to 20KHz flat		5	15	μV
E _t	Total Tracking Error	A _V = 0 to -24dB		0	1	dB
		A _V = -24 to -47dB		0	2	dB
S/N	Signal to Noise Ratio	All gains 0dB; V _O = 1V _{RMS} ;	95	106		dB
S _C	Channel Separation Left/Right		80	100		dB
d	Distortion	A _V = 0; V _I = 1V _{RMS} ;		0.01	0.08	%
BUS INPUT						
V _{IL}	Input Low Voltage				1	V
V _{IH}	Input High Voltage		3			V
I _{IN}	Input Current	V _{IN} = 0.4V	-5	0	5	μA
V _O	Output Voltage SDA Acknowledge	I _O = 1.6mA		0.4	0.8	V

TEST CIRCUIT

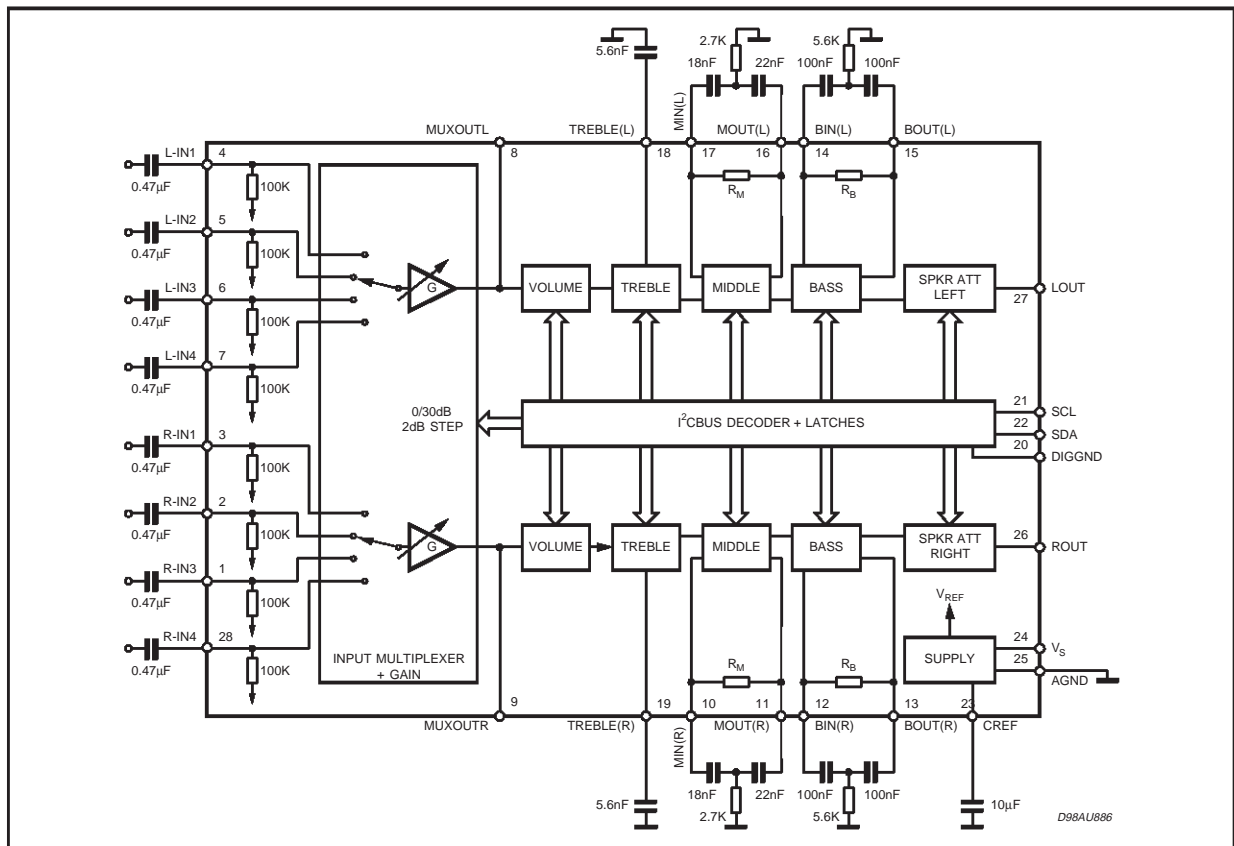

APPLICATION SUGGESTIONS

The first and the last stages are volume control blocks. The control range is 0 to -47dB (mute) for the first one, 0 to -79dB (mute) for the last one. Both of them have 1dB step resolution. The very high resolution allows the implementation of systems free from any noisy acoustical effect. The TDA7439DS audioprocessor provides 3 bands tones control.

Bass, Middle Stages

The Bass and the middle cells have the same structure.

The Bass cell has an internal resistor $R_i = 44K\Omega$ typical.

The Middle cell has an internal resistor $R_i = 25K\Omega$ typical.

Several filter types can be implemented, connecting external components to the Bass/Middle IN and OUT pins.

Figure 1.

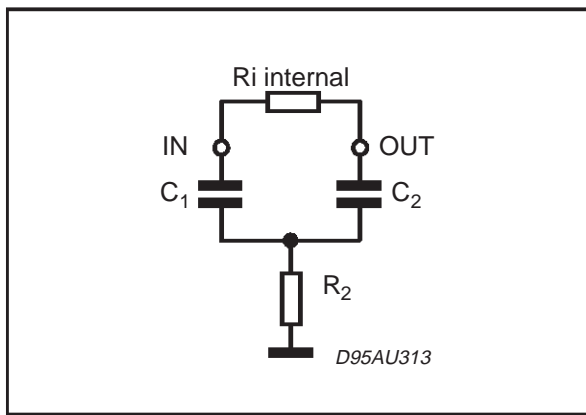
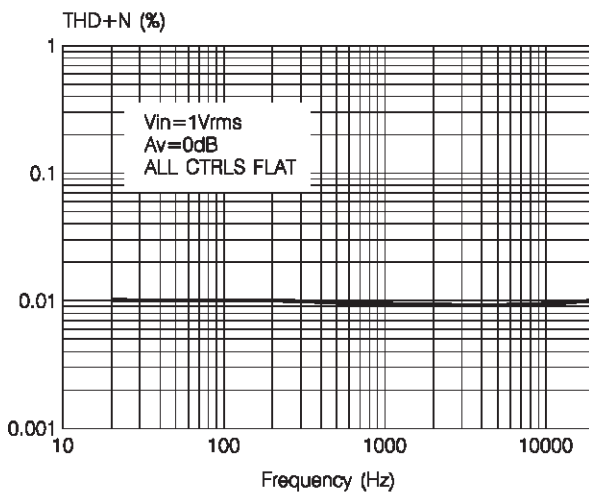

Figure 2: THD vs. frequency



The fig.1 refers to basic T Type Bandpass Filter starting from the filter component values (R_1 internal and R_2, C_1, C_2 external) the centre frequency F_c , the gain A_v at max. boost and the filter Q factor are computed as follows:

$$F_c = \frac{1}{2 \cdot \pi \cdot \sqrt{R_1 \cdot R_2 \cdot C_1 \cdot C_2}}$$

$$A_v = \frac{R_2 C_2 + R_2 C_1 + R_i C_1}{R_2 C_1 + R_2 C_2}$$

$$Q = \frac{\sqrt{R_1 \cdot R_2 \cdot C_1 \cdot C_2}}{R_2 C_1 + R_2 C_2}$$

Viceversa, once F_c , A_v , and R_i internal value are fixed, the external components values will be:

$$C_1 = \frac{A_v - 1}{2 \cdot \pi \cdot F_c \cdot R_i \cdot Q} \quad C_2 = \frac{Q^2 \cdot C_1}{A_v - 1 - Q^2}$$

$$R_2 = \frac{A_v - 1 - Q^2}{2 \cdot \pi \cdot C_1 \cdot F_c \cdot (A_v - 1) \cdot Q}$$

Treble Stage

The treble stage is a high pass filter whose time constant is fixed by an internal resistor (25K Ω typical) and an external capacitor connected between treble pins and ground

Typical responses are reported in Figg. 10 to 13.

CREF

The suggested 10 μ F reference capacitor (CREF) value can be reduced to 4.7 μ F if the application requires faster power ON.

Figure 3: THD vs. R_{LOAD}

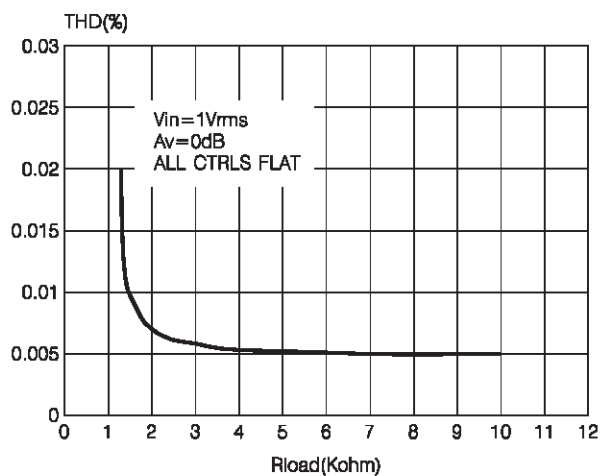

Figure 4: Channel separation vs. frequency

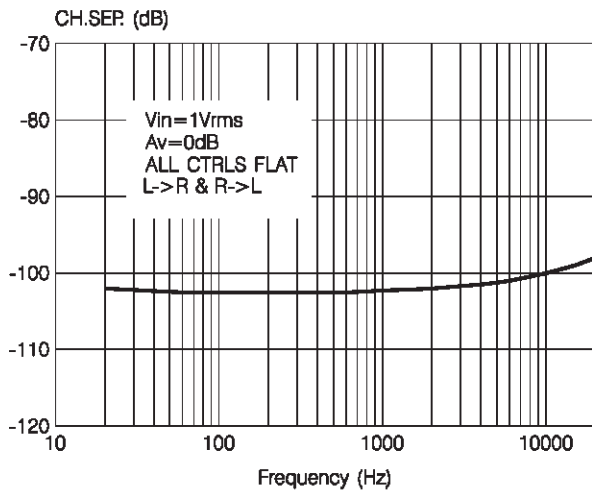

Figure 5: Bass response

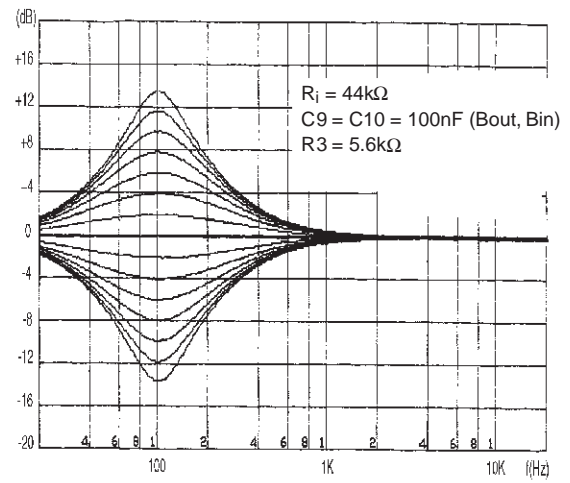

Figure 6: Middle response

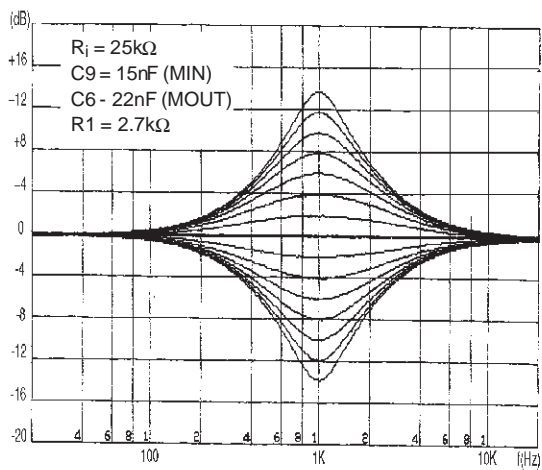

Figure 7: Treble response

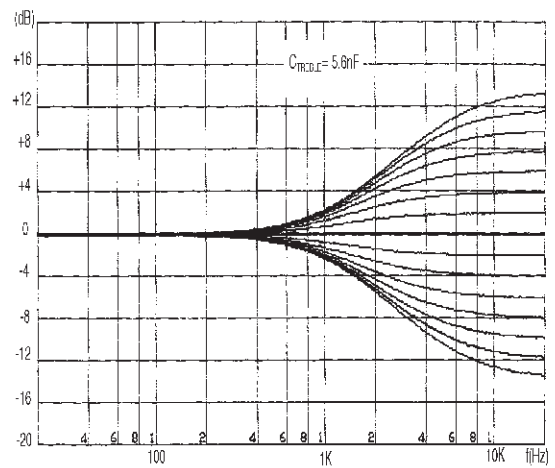
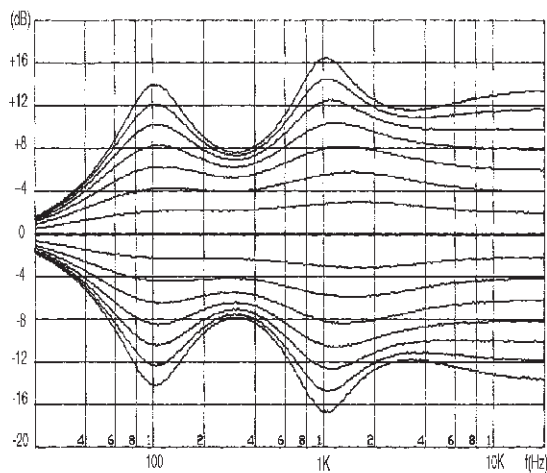

Figure 8: Typical tone response



I²C BUS INTERFACE

Data transmission from microprocessor to the TDA7439DS and vice versa takes place through the 2 wires I²C BUS interface, consisting of the two lines SDA and SCL (pull-up resistors to positive supply voltage must be connected).

Data Validity

As shown in fig. 9, the data on the SDA line must be stable during the high period of the clock. The HIGH and LOW state of the data line can only change when the clock signal on the SCL line is LOW.

Start and Stop Conditions

As shown in fig.10 a start condition is a HIGH to LOW transition of the SDA line while SCL is HIGH. The stop condition is a LOW to HIGH transition of the SDA line while SCL is HIGH.

Byte Format

Every byte transferred on the SDA line must contain 8 bits. Each byte must be followed by an ac-

knowledge bit. The MSB is transferred first.

Acknowledge

The master (μ P) puts a restive HIGH level on the SDA line during the acknowledge clock pulse (see fig. 11). The peripheral (audio processor) that acknowledges has to pull-down (LOW) the SDA line during this clock pulse.

The audio processor which has been addressed has to generate an acknowledge after the reception of each byte, otherwise the SDA line remains at the HIGH level during the ninth clock pulse time. In this case the master transmitter can generate the STOP information in order to abort the transfer.

Transmission without Acknowledge

Avoiding to detect the acknowledge of the audio processor, the μ P can use a simpler transmission: simply it waits one clock without checking the slave acknowledging, and sends the new data.

This approach of course is less protected from misworking.

Figure 9: Data Validity on the I²C BUS

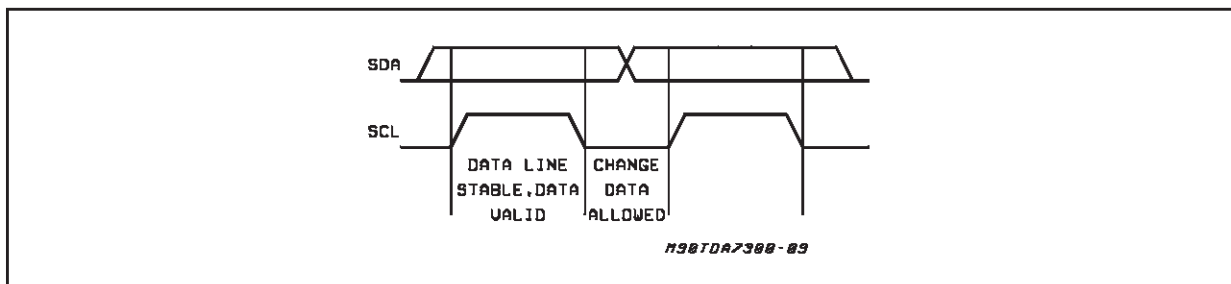

Figure 10: Timing Diagram of I²C BUS

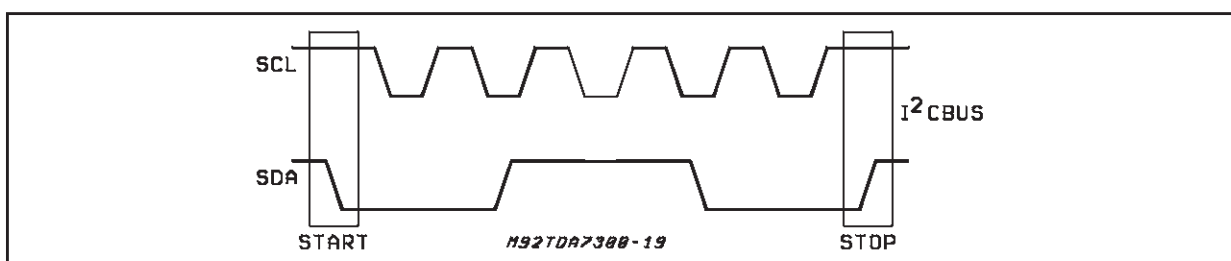
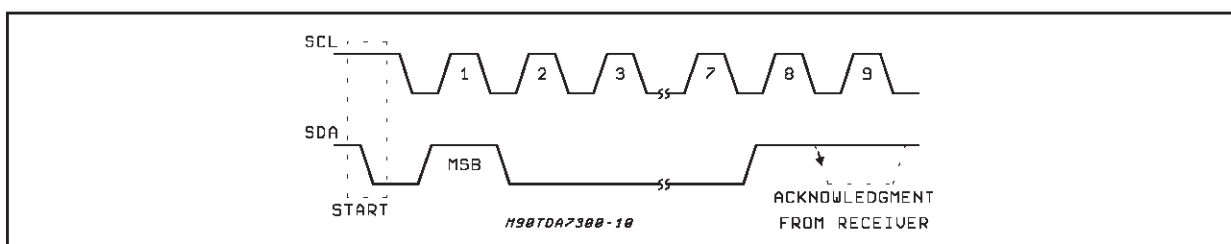

Figure 11: Acknowledge on the I²C BUS



TDA7439DS

SOFTWARE SPECIFICATION

Interface Protocol

The interface protocol comprises:

- A start condition (S)
- A chip address byte, containing the

TDA7439DS address

- A subaddress bytes
- A sequence of data (N byte + acknowledge)
- A stop condition (P)

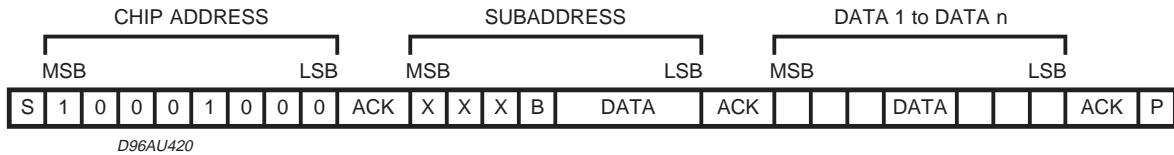

ACK = Acknowledge
 S = Start
 P = Stop
 A = Address
 B = Auto Increment

EXAMPLES

No Incremental Bus

The TDA7439DS receives a start condition, the

correct chip address, a subaddress with the B = 0 (no incremental bus), N-data (all these data concern the subaddress selected), a stop condition.

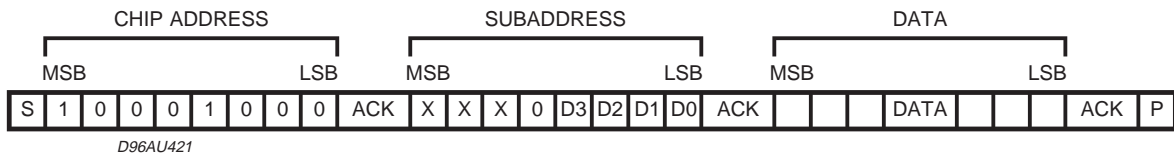

Incremental Bus

The TDA7439DS receive a start conditions, the correct chip address, a subaddress with the B = 1 (incremental bus): now it is in a loop condition with an autoincrease of the subaddress whereas

SUBADDRESS from "XXX1000" to "XXX1111" of DATA are ignored. The DATA 1 concern the subaddress sent, and the DATA 2 concern the subaddress sent plus one in the loop etc, and at the end it receives the stop condition.

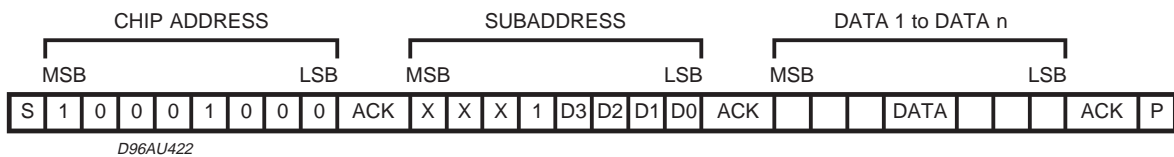

POWER ON RESET CONDITION

INPUT SELECTION	IN2
INPUT GAIN	28dB
VOLUME	MUTE
BASS	0dB
MIDDLE	2dB
TREBLE	2dB
SPEAKER	MUTE

DATA BYTES

Address = 88 HEX (ADDR:OPEN).

FUNCTION SELECTION: First byte (subaddress)

MSB							LSB	SUBADDRESS
D7	D6	D5	D4	D3	D2	D1	D0	
X	X	X	B	0	0	0	0	INPUT SELECT
X	X	X	B	0	0	0	1	INPUT GAIN
X	X	X	B	0	0	1	0	VOLUME
X	X	X	B	0	0	1	1	BASS
X	X	X	B	0	1	0	0	MIDDLE
X	X	X	B	0	1	0	1	TREBLE
X	X	X	B	0	1	1	0	SPEAKER ATTENUATE "R"
X	X	X	B	0	1	1	1	SPEAKER ATTENUATE "L"

B = 1: INCREMENTAL BUS ACTIVE

B = 0: NO INCREMENTAL BUS

X = DON'T CARE

INPUT SELECTION

MSB							LSB	INPUT MULTIPLEXER
D7	D6	D5	D4	D3	D2	D1	D0	
X	X	X	X	X	X	0	0	IN4
X	X	X	X	X	X	0	1	IN3
X	X	X	X	X	X	1	0	IN2
X	X	X	X	X	X	1	1	IN1

TDA7439DS

DATA BYTES (continued)

INPUT GAIN SELECTION

MSB							LSB		INPUT GAIN
D7	D6	D5	D4	D3	D2	D1	D0	2dB STEPS	
				0	0	0	0	0dB	
				0	0	0	1	2dB	
				0	0	1	0	4dB	
				0	0	1	1	6dB	
				0	1	0	0	8dB	
				0	1	0	1	10dB	
				0	1	1	0	12dB	
				0	1	1	1	14dB	
				1	0	0	0	16dB	
				1	0	0	1	18dB	
				1	0	1	0	20dB	
				1	0	1	1	22dB	
				1	1	0	0	24dB	
				1	1	0	1	26dB	
				1	1	1	0	28dB	
				1	1	1	1	30dB	

GAIN = 0 to 30dB

VOLUME SELECTION

MSB							LSB		VOLUME
D7	D6	D5	D4	D3	D2	D1	D0	1dB STEPS	
					0	0	0	0dB	
					0	0	1	-1dB	
					0	1	0	-2dB	
					0	1	1	-3dB	
					1	0	0	-4dB	
					1	0	1	-5dB	
					1	1	0	-6dB	
					1	1	1	-7dB	
	0	0	0	0				0dB	
	0	0	0	1				-8dB	
	0	0	1	0				-16dB	
	0	0	1	1				-24dB	
	0	1	0	0				-32dB	
	0	1	0	1				-40dB	
	X	1	1	1	X	X	X	MUTE	

VOLUME = 0 to 47dB/MUTE

DATA BYTES (continued)**BASS SELECTION**

MSB							LSB	BASS
D7	D6	D5	D4	D3	D2	D1	D0	2dB STEPS
				0	0	0	0	-14dB
				0	0	0	1	-12dB
				0	0	1	0	-10dB
				0	0	1	1	-8dB
				0	1	0	0	-6dB
				0	1	0	1	-4dB
				0	1	1	0	-2dB
				0	1	1	1	0dB
				1	1	1	1	0dB
				1	1	1	0	2dB
				1	1	0	1	4dB
				1	1	0	0	6dB
				1	0	1	1	8dB
				1	0	1	0	10dB
				1	0	0	1	12dB
				1	0	0	0	14dB

MIDDLE SELECTION

MSB							LSB	MIDDLE
D7	D6	D5	D4	D3	D2	D1	D0	2dB STEPS
				0	0	0	0	-14dB
				0	0	0	1	-12dB
				0	0	1	0	-10dB
				0	0	1	1	-8dB
				0	1	0	0	-6dB
				0	1	0	1	-4dB
				0	1	1	0	-2dB
				0	1	1	1	0dB
				1	1	1	1	0dB
				1	1	1	0	2dB
				1	1	0	1	4dB
				1	1	0	0	6dB
				1	0	1	1	8dB
				1	0	1	0	10dB
				1	0	0	1	12dB
				1	0	0	0	14dB

TDA7439DS

DATA BYTES (continued)

TREBLE SELECTION

MSB							LSB	TREBLE
D7	D6	D5	D4	D3	D2	D1	D0	2dB STEPS
				0	0	0	0	-14dB
				0	0	0	1	-12dB
				0	0	1	0	-10dB
				0	0	1	1	-8dB
				0	1	0	0	-6dB
				0	1	0	1	-4dB
				0	1	1	0	-2dB
				0	1	1	1	0dB
				1	1	1	1	0dB
				1	1	1	0	2dB
				1	1	0	1	4dB
				1	1	0	0	6dB
				1	0	1	1	8dB
				1	0	1	0	10dB
				1	0	0	1	12dB
				1	0	0	0	14dB

SPEAKER ATTENUATE SELECTION

MSB							LSB	SPEAKER ATTENUATION
D7	D6	D5	D4	D3	D2	D1	D0	1dB
					0	0	0	0dB
					0	0	1	-1dB
					0	1	0	-2dB
					0	1	1	-3dB
					1	0	0	-4dB
					1	0	1	-5dB
					1	1	0	-6dB
					1	1	1	-7dB
	0	0	0	0				0dB
	0	0	0	1				-8dB
	0	0	1	0				-16dB
	0	0	1	1				-24dB
	0	1	0	0				-32dB
	0	1	0	1				-40dB
	0	1	1	0				-48dB
	0	1	1	1				-56dB
	1	0	0	0				-64dB
	1	0	0	1				-72dB
	1	1	1	1	X	X	X	MUTE

SPEAKER ATTENUATION = 0 to -79dB/MUTE

PIN: 23

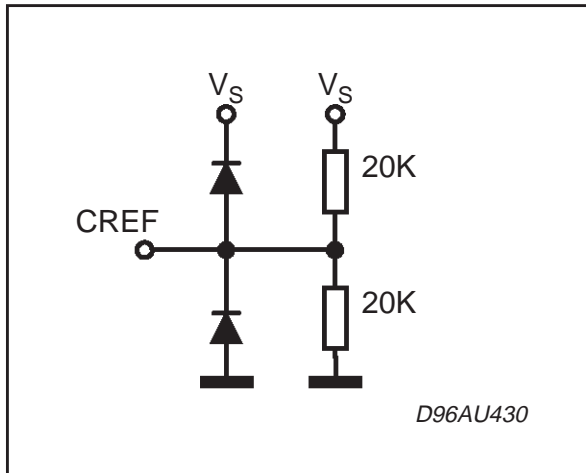

PINS: 26,27

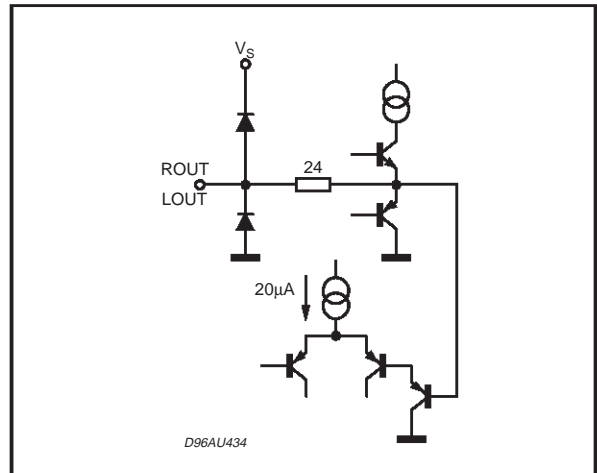

PINS: 1, 2, 3, 4, 5, 6, 7, 28

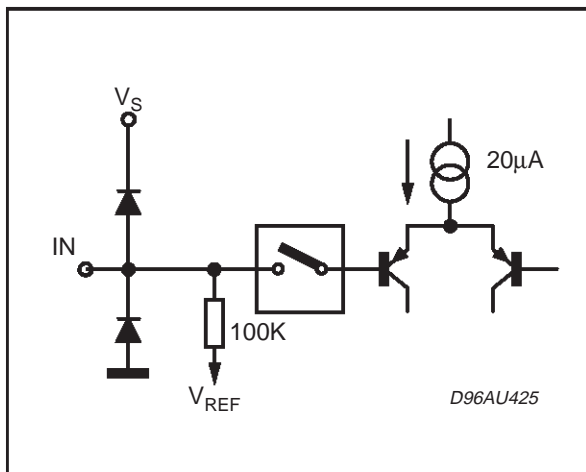

PINS: 8, 9

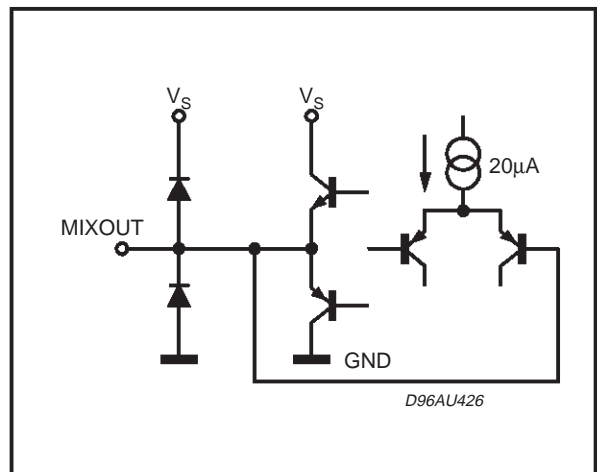

PINS: 11, 16

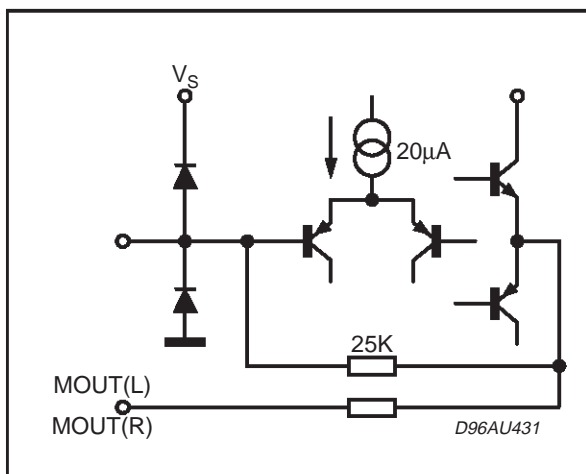

PINS: 10, 17

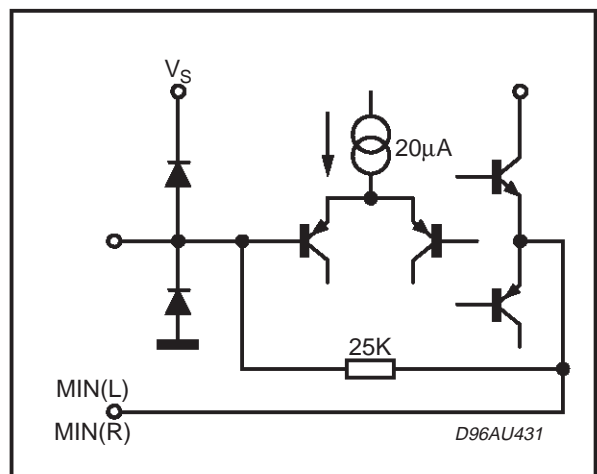

PINS: 12, 14

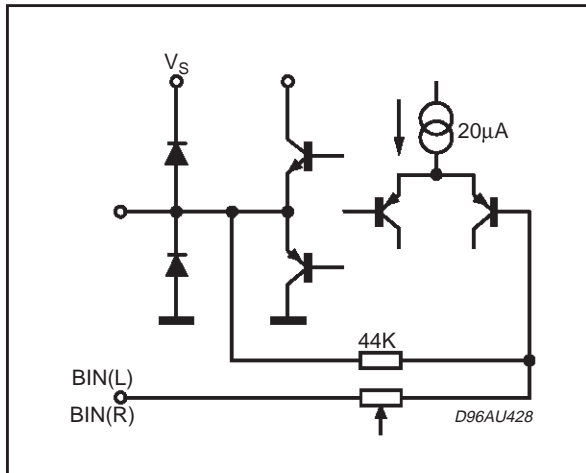

PINS: 13, 15

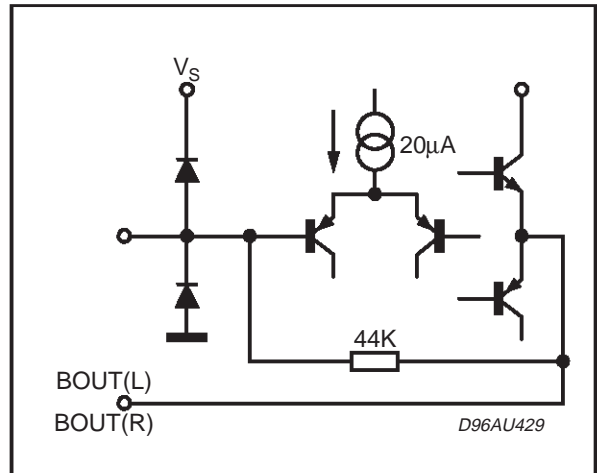

PIN: 18, 19

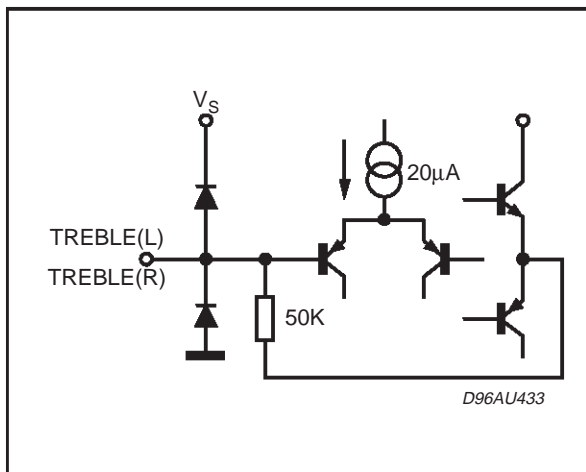

PIN: 21

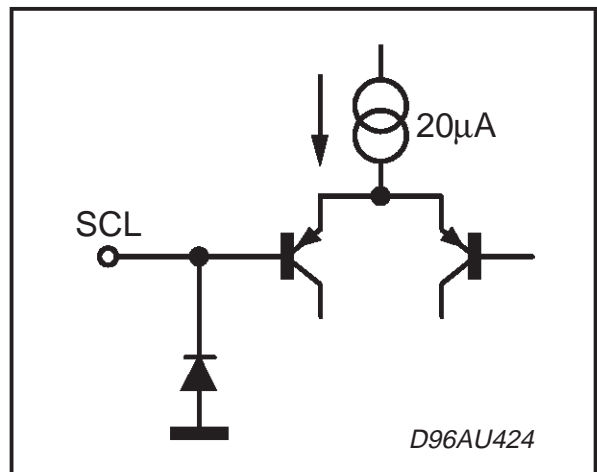

PIN: 22

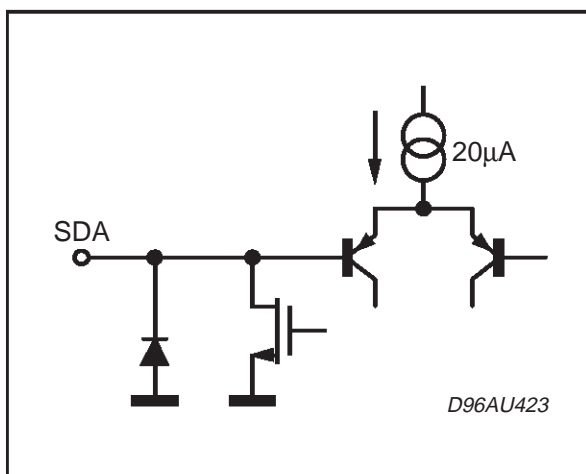

DIM.	mm			inch		
	MIN.	TYP.	MAX.	MIN.	TYP.	MAX.
A			2.65			0.104
a1	0.1		0.3	0.004		0.012
b	0.35		0.49	0.014		0.019
b1	0.23		0.32	0.009		0.013
C		0.5			0.020	
c1	45° (typ.)					
D	17.7		18.1	0.697		0.713
E	10		10.65	0.394		0.419
e		1.27			0.050	
e3		16.51			0.65	
F	7.4		7.6	0.291		0.299
L	0.4		1.27	0.016		0.050
S	8° (max.)					

OUTLINE AND MECHANICAL DATA

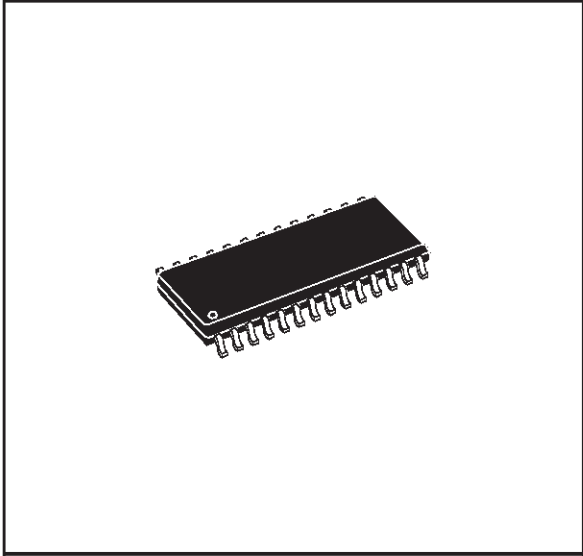

SO28

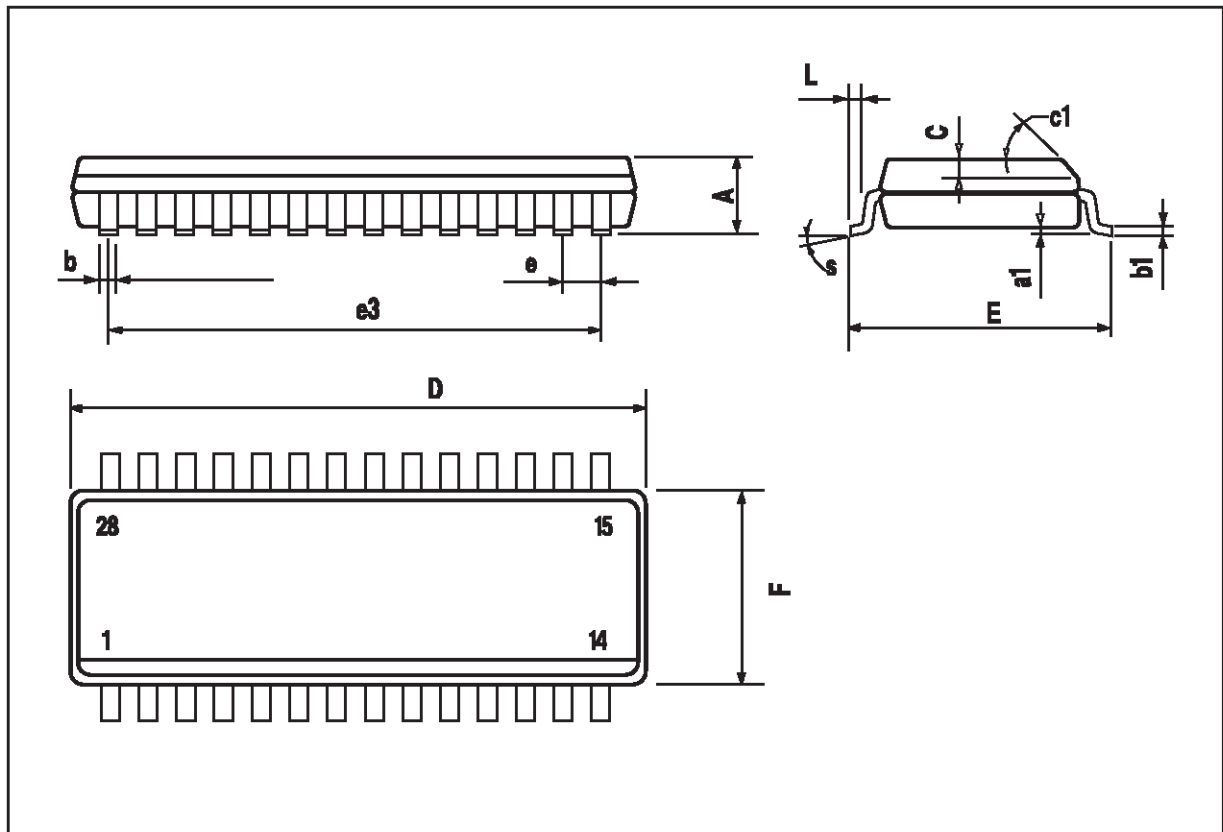

Information furnished is believed to be accurate and reliable. However, STMicroelectronics assumes no responsibility for the consequences of use of such information nor for any infringement of patents or other rights of third parties which may result from its use. No license is granted by implication or otherwise under any patent or patent rights of STMicroelectronics. Specification mentioned in this publication are subject to change without notice. This publication supersedes and replaces all information previously supplied. STMicroelectronics products are not authorized for use as critical components in life support devices or systems without express written approval of STMicroelectronics.

The ST logo is a registered trademark of STMicroelectronics
© 1999 STMicroelectronics – Printed in Italy – All Rights Reserved
STMicroelectronics GROUP OF COMPANIES

Australia - Brazil - Canada - China - France - Germany - Italy - Japan - Korea - Malaysia - Malta - Mexico - Morocco - The Netherlands -
Singapore - Spain - Sweden - Switzerland - Taiwan - Thailand - United Kingdom - U.S.A.
<http://www.st.com>