

GP2TC1

■ Features

1. Adopted diffusive reflection method
(Wide detecting range : 0 to 1.0mg/cm²)
2. Analog output according to amount of reflective light
(adhesive volume of toner)
3. 2 system output : adhesive volume of black toner
adhesive volume of color toner
4. Detection range of toner density
(Y, M, C : 0 to 1.0mg/cm²)
(K : 0 to 0.6mg/cm²)
5. High resolution (0.1mg/cm²)
6. Output can be adjusted by control of LED current

■ Applications

1. Full-color copiers
2. Color LBPs

■ Absolute Maximum Ratings

(Ta=25°C, Vcc=5V)

Parameter	Symbol	Rating	Unit
Operating voltage	V _{CC}	-0.3 to 7	V
LED current	I _F	50	mA
Output terminal voltage	V _O	-0.3 to V _{CC} +0.3	V
Operating temperature	T _{opr}	0 to +60	°C
Storage temperature	T _{stg}	-20 to +70	°C

■ Recommend Operating Conditions

Parameter	Symbol	Rating	Unit
Supply voltage	V _{CC}	4.5 to 5.5	V
Detection distance range	L	11.0 to 11.5	mm

Color Toner Density (Adhesive Volume) Sensor by Diffusive Reflection Method

■ Outline Dimensions

(Unit : mm)

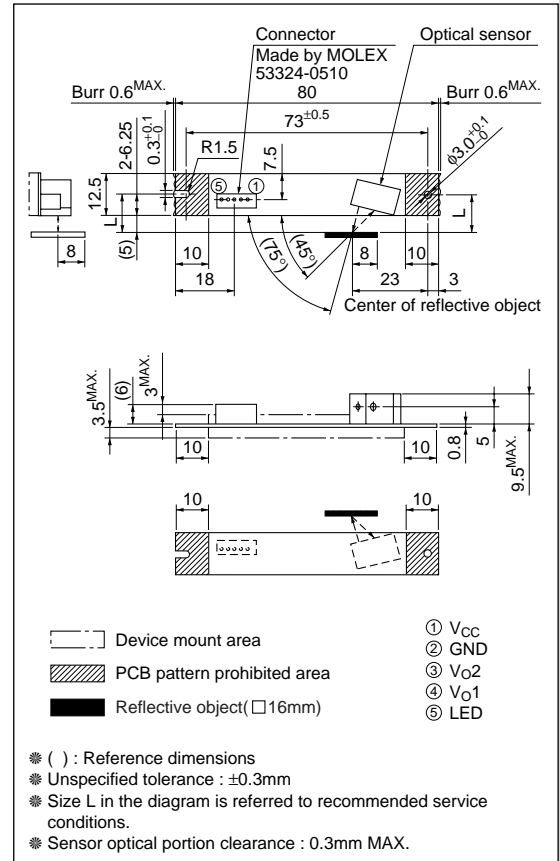

■ Electro-optical Characteristics

(Ta=25°C, Vcc=5V)

Parameter	Symbol	Conditions	MIN.	TYP.	MAX.	Unit
Output voltage	V_{O1A}	Reflective object A ($I_{FM}=20mA$)	0.70	1.06	1.42	V
	V_{O2A}		1.68	2.63	3.58	V
	V_{O10}	LED current $I_{FM}=0mA$	0.3	0.6	0.9	V
	V_{O20}		0.3	1.1	1.9	V
Displacement of output voltage	ΔV_{O1BA}	Displacement of output voltage V_{O1} when reflective object is changed from A to B ($I_{FM}=20mA$)	1.30	1.45	1.60	V
	ΔV_{O2AC}	Displacement of output voltage V_{O2} when reflective object is changed from C to A ($I_{FM}=20mA$)	1.06	1.21	1.36	V
	ΔV_{O1A0}	$V_{O1A}-V_{O10}$	0.40	0.46	0.52	V
	ΔV_{O2A0}	$V_{O2A}-V_{O20}$	1.38	1.53	1.68	V
Rise time	t_r	Reflective object C (Munsell N2 no gloss (Reflectivity 3.1%)) ($I_{FM}=20mA$)	-	70	300	μs
Fall time	t_f		-	70	300	μs
Consumption current	I_{CC}	Consumption current at LED current $I_{FM}=0mA$	-	4	12	mA

Fig.1 Internal Block Diagram

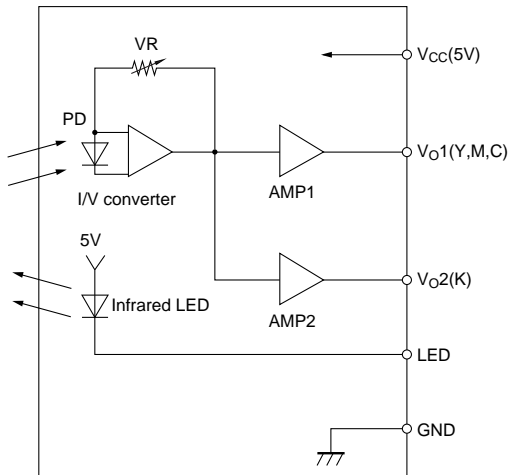

Fig.2 Schematic measurement block diagram

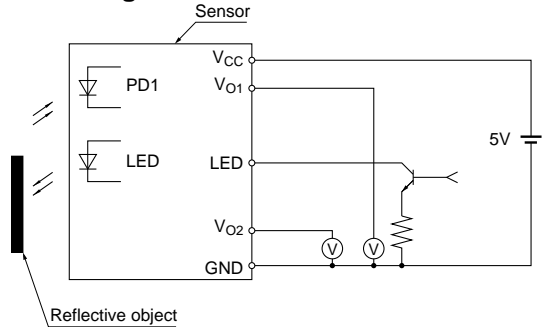

Fig.3 LED lighting condition

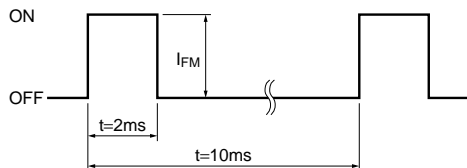

Fig.4 Response Time

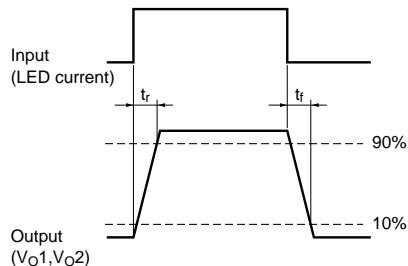
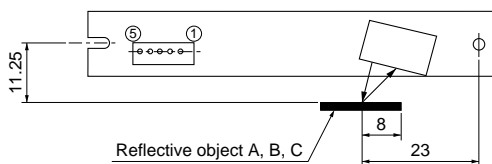

Fig.5 Measurement Condition



Reflective object A : Munsell N4.5 No gloss (Reflectivity 15.6%)
 Reflective object B : Munsell N7.75 No gloss (Reflectivity 54.8%)
 Reflective object C : Munsell N2 No gloss (Reflectivity 3.1%)

■ Example of application

1. Apply $V_{CC}=5V$ and measure V_{O10} at V_{O1} , V_{O20} at V_{O2} .
2. In order to stabilize output voltage measure 3. to 5. on the LED lighting condition shown in Fig.3 for example.
3. Measure the output voltage V_{O2} and adjust I_{FM} in order to fix ΔV_{O21} (determine value by your actual application). After the adjustment, memorize the values, V_{O1} , V_{O2} and I_{FM} , (If there are the initial memorized values, V_{O1} , V_{O2} and I_{FM} , measure V_{O1} and V_{O2} at memorized I_{FM} . If there are difference between the measured values and memorized values adjust I_{FM} to let V_{O1} and V_{O2} be initial values.)
4. Attach the color toner and measure the output voltage at V_{O1} (I_{FM} at the value memorized at 3.). Determine the output voltage difference ΔV_{O1} between the measured value and memorized value V_{O1} at 3, and adjust the attached color toner amount.
5. Attach the black toner and measure the output voltage at V_{O2} (I_{FM} at the value memorized at 3.). Determine the output voltage difference ΔV_{O2} between the measured value and memorized value V_{O2} at 3, and adjust the attached black toner amount.
6. After the measurement, set $I_{FM}=0mA$ and turn off the LED.
7. To measure them again, start from 1.

Note V_{O10} : Output voltage at $I_{FM}=0mA$
 V_{O20} : Output voltage at $I_{FM}=0mA$
 V_{O1} : V_{O1} terminal output voltage at no toner
 V_{O2} : V_{O2} terminal output voltage at no toner
 ΔV_{O1} : Output voltage when black toner is attached- V_{O1}
 ΔV_{O2} : Output voltage when black toner is attached- V_{O2}
 ΔV_{O21} : $V_{O2}-V_{O20}$
 I_{FM} : LED current

Fig.6 Output Voltage vs. Reflectivity of Reflective Objects

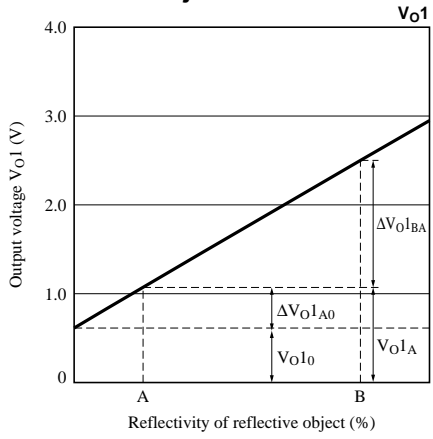
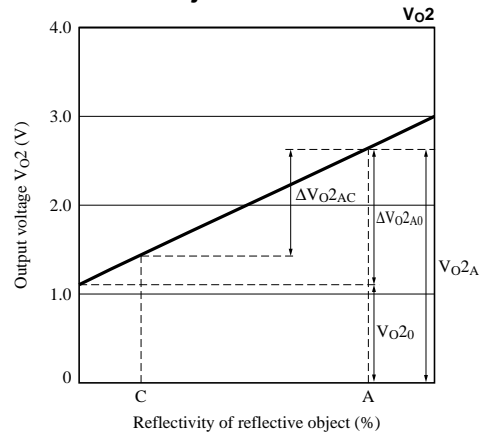

Fig.7 Output Voltage vs. Reflectivity of Reflective Objects



NOTICE

- The circuit application examples in this publication are provided to explain representative applications of SHARP devices and are not intended to guarantee any circuit design or license any intellectual property rights. SHARP takes no responsibility for any problems related to any intellectual property right of a third party resulting from the use of SHARP's devices.
- Contact SHARP in order to obtain the latest device specification sheets before using any SHARP device. SHARP reserves the right to make changes in the specifications, characteristics, data, materials, structure, and other contents described herein at any time without notice in order to improve design or reliability. Manufacturing locations are also subject to change without notice.
- Observe the following points when using any devices in this publication. SHARP takes no responsibility for damage caused by improper use of the devices which does not meet the conditions and absolute maximum ratings to be used specified in the relevant specification sheet nor meet the following conditions:
 - (i) The devices in this publication are designed for use in general electronic equipment designs such as:
 - Personal computers
 - Office automation equipment
 - Telecommunication equipment [terminal]
 - Test and measurement equipment
 - Industrial control
 - Audio visual equipment
 - Consumer electronics
 - (ii) Measures such as fail-safe function and redundant design should be taken to ensure reliability and safety when SHARP devices are used for or in connection with equipment that requires higher reliability such as:
 - Transportation control and safety equipment (i.e., aircraft, trains, automobiles, etc.)
 - Traffic signals
 - Gas leakage sensor breakers
 - Alarm equipment
 - Various safety devices, etc.
 - (iii) SHARP devices shall not be used for or in connection with equipment that requires an extremely high level of reliability and safety such as:
 - Space applications
 - Telecommunication equipment [trunk lines]
 - Nuclear power control equipment
 - Medical and other life support equipment (e.g., scuba).
- Contact a SHARP representative in advance when intending to use SHARP devices for any "specific" applications other than those recommended by SHARP or when it is unclear which category mentioned above controls the intended use.
- If the SHARP devices listed in this publication fall within the scope of strategic products described in the Foreign Exchange and Foreign Trade Control Law of Japan, it is necessary to obtain approval to export such SHARP devices.
- This publication is the proprietary product of SHARP and is copyrighted, with all rights reserved. Under the copyright laws, no part of this publication may be reproduced or transmitted in any form or by any means, electronic or mechanical, for any purpose, in whole or in part, without the express written permission of SHARP. Express written permission is also required before any use of this publication may be made by a third party.
- Contact and consult with a SHARP representative if there are any questions about the contents of this publication.