

AUDIO SURROUND PROCESSOR WITH I²C BUS

The S1A0686X01 is a monolithic integrated circuits designed for the audio surround functions in TV or Audio systems. This device functions volume, balance, tone control and three surround modes. The S1A0686X01 has a I²C serial bus function.

FUNCTION

- Three surround modes : MUSIC, MOVIE, SIMULATED
- Vocal MIX
- L + R LPF AMP
- Volume & balance control
- Tone (bass/treble) control
- Rear, woofer volume control
- I²C BUS control

FEATURES

- Lower operating voltage : 9V
- All function controlled by I²C BUS
- Minimum number of external parts required
- Add Vocal Mix function
- Available three surround mode : MUSIC, MOVIE, SIMULATED
- LIN, RIN, input impedance : 50k Ω , output pin impedance : under 100 Ω

ORDERING INFORMATION

Device	Package	Operating Temperature
S1A0686X01-A0B0	32-SDIP-400	-20°C – 75°C

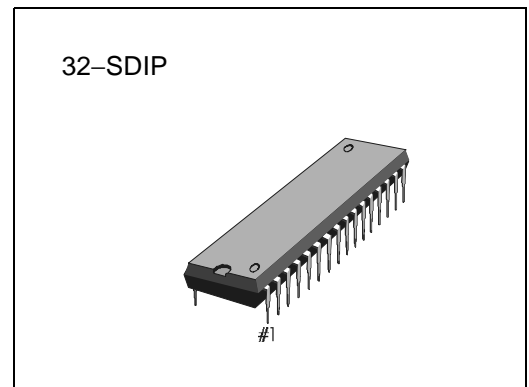

BLOCK DIAGRAM

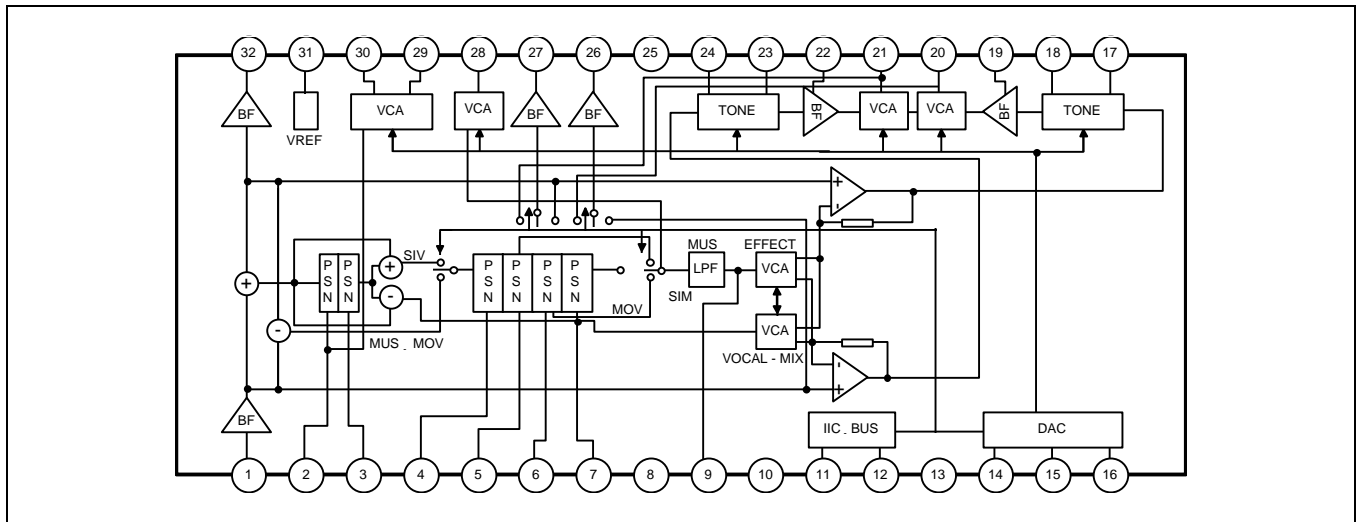

PIN CONFIGURATION

Pin No	DESCRIPTION	Pin No	DESCRIPTION
1	L input	17	TREBLE_R Cap.
2	Phase shift filter 1	18	BASS_R Cap.
3	Phase shift filter 2	19	OFFSET_R Cap.
4	Phase shift filter 3	20	R output
5	Phase shift filter 4	21	L output
6	Phase shift filter 5	22	OFFSET_L Cap.
7	Phase shift filter 6	23	BASS_L Cap.
8	V _{CC}	24	TREBLE_L Cap.
9	LPF (9KHz)	25	GROUND (Analog)
10	N.C	26	R1 output (Monitor)
11	SCL (I ² C BUS)	27	L1 output (Monitor)
12	SDA (I ² C BUS)	28	REAR output
13	GROUND (Digital)	29	WOOFER output
14	WOOC	30	WOOFER LPF Cap
15	VOLC	31	VBIAS (A _{CC} /2)
16	BALC	32	R input

ABSOLUTE MAXIMUM RATING (T_A =25°C)

Characteristic	Symbol	Value	Unit
Supply Voltage	V _{CC}	12	V
Power Dissipation	P _D	1000	mW
Operating Temperature	T _{OPR}	-25 – +75	°C
Storage Temperature	T _{STG}	-55 – +125	°C

ELECTRICAL CHARACTERISTICS

(V_{CC} = 9V, T_A = 25°C, V_{in} (= Lin, Rin) = 500mVrms, f = 1kHz unless otherwise specified)

Characteristic	Symbol	Test Condition	Min.	Typ.	Max.	Unit
Circuit Current	I _{CC}	No Signal, SW1 = b	25	35	45	mA
Reference Voltage	V _{REF}	No Signal, SW1 = b	4.3	4.5	4.7	V
Pin14 Voltage	VP14	No Signal, SW1 = b	5.6	6.0	6.4	V
Pin15 Voltage	VP15	No Signal, SW1 = b	5.6	6.0	6.4	V
Pin16 Voltage	VP16	No Signal, SW1 = b	4.2	4.6	5.0	V
Volume Max 1.1	Vmax1.1	LIN	-1.5	0.0	1.5	dB
Volume Max 1.2	Vmax1.2	LIN	-1.5	0.0	1.5	dB
Volume Max 2.1	Vmax2.1	LIN	-1.5	0.0	1.5	dB
Volume Max 1.3	Vmax1.3	RIN	-1.5	0.0	1.5	dB
Volume Max 1.4	Vmax1.4	RIN	-1.5	0.0	1.5	dB
Volume Max 2.2	Vmax2.2	RIN	-1.5	0.0	1.5	dB
Channel Balance 1.1	Cbal1.1	Lout, Rout Δ	-1.0	0.0	1.0	dB
Channel Balance 1.2	Cbal1.2	L1out, R2out ΔG	-1.0	0.0	1.0	dB
Channel Balance 2	Cbal2	Reout ΔG	-1.0	0.0	1.0	dB
Volume Max 3	Vmax3	f = 100Hz	-1.5	0	1.5	%
T. H. D 1.1	THD1.1	LIN	-	0.1	0.5	%
T. H. D 1.1	THD1.2	LIN	-	0.1	0.5	%
T. H. D 1.1	THD1.3	LIN	-	0.1	0.5	%
T. H. D 1.1	THD1.4	RIN	-	0.1	0.5	%
T. H. D 1.1	THD1.5	RIN	-	0.1	0.5	%
T. H. D 1.1	THD1.6	RIN	-	0.1	0.5	%
T. H. D 1.1	THD2	f = 100Hz	-	0.1	0.5	%
Flat Charac. 1.1	Vflat1.1	LIN, f = 100Hz	-2.0	0.0	2.0	dB

Characteristic	Symbol	Test Condition	Min.	Typ.	Max.	Unit
Flat Charac. 2.1	Vflat2.1	LIN, f = 10kHz	-2.0	0.0	2.0	dB
Flat Charac. 1.2	Vflat1.2	RIN, f = 10Hz	-2.0	0.0	2.0	dB
Flat Charac. 2.2	Vflat2.2	RIN, f = 10kHz	-2.0	0.0	2.0	dB
Cross Talk L	CT1	LIN, Rout	-	-70.0	-64.0	dB
Cross Talk R	CTr	RIN, Lout	-	-70.0	-64.0	dB
Cross Talk L1	CT11	LIN, R1out	-	-70.0	-64.0	dB
Cross Talk R1	CT1	RIN, L1out	-	-70.0	-64.0	dB
MAX. Output Voltage1.1	V _{OMAX} 1.1	LIN, T.H.D = 1%	2.2	2.4	-	V _{rms}
MAX. Output Voltage1.2	V _{OMAX} 1.2	RIN, T.H.D = 1%	2.2	2.4	-	V _{rms}
MAX. Output Voltage1.3	V _{OMAX} 1.3	LIN, T.H.D = 1%	2.2	2.4	-	V _{rms}
MAX. Output Voltage1.4	V _{OMAX} 1.4	RIN, T.H.D = 1%	2.2	2.4	-	V _{rms}
MAX. Output Voltage1.5	V _{OMAX} 1.5	LIN, T.H.D = 1%	2.2	2.4	-	V _{rms}
MAX. Output Voltage 2	V _{OMAX} 2	f = 100Hz, T.H.D = 1%	2.2	2.4	-	V _{rms}
Noise Level 1	Vno1	Rg = 600Ω, 20-20kHz BPF	-	40.0	80.0	μV _{rms}
Noise Level 2	Vno2	Rg = 600Ω 20 - 20kHz BPF	-	40.0	80.0	μV _{rms}
Noise Level 3	Vno3	Rg = 600Ω 20 - 20kHz BPF	-	40.0	80.0	μV _{rms}
Noise Level 4	Vno4	Rg = 600Ω 20 - 20kHz BPF	-	40.0	80.0	μV _{rms}
Noise Level 5	Vno5	Rg = 600Ω 20 - 20kHz BPF	-	40.0	80.0	μV _{rms}
Noise Level 6	Vno6	Rg = 600Ω 20 - 20kHz BPF	-	40.0	80.0	μV _{rms}
Music Gain1	Gmus1	Music Mode, LIN	5.0	7.0	9.0	dB
Music Gain2	Gmus2	Music Mode, RIN	5.0	7.0	9.0	dB
Channel Balance3	Cbal3	Lout, Rout ΔG	-1.0	0.0	1.0	dB
Movie Gain1	Gmov1	Movie Mode, LIN	0.0	5.0	8.0	dB
Movie Gain1	Gmov2	Movie Mode, RIN	0.0	5.0	8.0	dB
Channel Balance4	Cbal4	Lout, Rout ΔG	-1.0	0.0	1.0	dB
Simulated Gain L1	Gsiml1	Simulated Mode	-	-3.0	0.0	dB
Simulated Gain R1	Gsimr1	Simulated Mode	0.0	3.0	6.0	dB
Simulated Gain L2	Gsiml2	Simulated Mode, f = 4kHz	2.0	5.0	8.0	dB
Simulated Gain R2	Gsimr2	Simulated Mode, f = 4kHz	-	-3.0	2.0	dB

Characteristic	Symbol	Test Condition	Min.	Typ.	Max.	Unit
Bass Effect1	Vbass1	OFF Mode, Ctrl Max f = 100Hz	8.0	10.0	12.0	dB
Bass Effect2	Vbass2	f = 100Hz	8.0	10.0	12.0	dB
Bass Effect3	Vbass3	Ctrl Data = 110000, f = 100Hz	3.0	5.0	7.0	dB
Bass Effect4	Vbass4	f = 100Hz	3.0	5.0	7.0	dB
Bass Effect5	Vbass5	Ctrl Data = 110000, f = 100Hz	-7.0	-5.0	-3.0	dB
Bass Effect6	Vbass6	f = 100Hz	-7.0	-5.0	-3.0	dB
Bass Effect7	Vbass7	Ctrl Min, f = 100Hz	-12.0	-10.0	-8.0	dB
Bass Effect8	Vbass8	f = 100Hz	-12.0	-10.0	-8.0	dB
Treble Effect1	Vtreb1	Ctrl Max, f = 10kHz	8.0	10.0	12.0	dB
Treble Effect2	Vtreb2	f = 10kHz	8.0	10.0	12.0	dB
Treble Effect3	Vtreb3	Ctrl Data = 110000, f = 10kHz	3.0	5.0	7.0	dB
Treble Effect4	Vtreb4	f = 10kHz	3.0	5.0	7.0	dB
Treble Effect5	Vtreb5	Ctrl Data = 010000, f = 10kHz	-7.0	-5.0	-3.0	dB
Treble Effect6	Vtreb6	f = 10kHz	-7.0	-5.0	-3.0	dB
Treble Effect7	Vtreb7	Ctrl Min, f = 10kHz	-12.0	-10.0	-8.0	dB
Treble Effect8	Vtreb8	f = 10kHz	-12.0	-10.0	-8.0	dB
Balance Ctrl L	Vbalct1	Ctrl Data = 110000	-11.0	-8.0	-4.0	dB
Balance Ctrl R	Vbalctr	Ctrl Data = 010000	-11.0	-8.0	-4.0	dB
Balance Min L	Vball	Ctrl MW	-	-70.0	-64.0	dB
Balance Min R	Vbair	Ctrl MW	-	-70.0	-64.0	dB
Volume Center 1.1	Vmid1.1	Main Volume Ctrl Center LIN	-16.0	-13.0	-10.0	dB
Volume Center 1.2	Vmid1.2	RIN	-16.0	-13.0	-10.0	dB
Volume Center 1.3	Vmid1.3	Rear Volume Ctrl Center LIN	-16.0	-13.0	-10.0	dB
Volume Center 1.4	Vmid1.4	RIN	-16.0	-13.0	-10.0	dB
Volume Center 2	Vmid2	Woofer Volume Ctrl Min, LIN, RIN, f = 100Hz Wout	-16.0	-13.0	-10.0	dB
Volume Min 1.1	Vmin 1.1	Main Volume Ctrl Min LIN	-	-80.0	-74.0	dB

Characteristic	Symbol	Test Condition	Min.	Typ.	Max.	Unit
Volume Min 1.2	Vmin 1.2	RIN	–	–80.0	–74.0	dB
Volume Min 1.3	Vmin 1.3	Rear Volume Ctrl Min LIN	–	–80.0	–74.0	dB
Volume Min 1.4	Vmin 1.4	RIN	–	–80.0	–74.0	dB
Volume Min 2	Vmin 2	Woofers Volume Ctrl Min, LIN, RIN, f = 100Hz, Wout	–	–80.0	–74.0	dB
Vocal - Mix 1.1	Vmix 1.1	f = 1kHz, Effect Ctrl Min, LIN, Lout	5.0	8.0	11.0	dB
Vocal - Mix 1.2	Vmix 1.2	RIN, Rout	5.0	8.0	11.0	dB
Vocal - Mix 2.1	Vmix 2.1	f =100Hz, LIN, Lout	–0.5	2.5	5.5	dB
Vocal - Mix 2.2	Vmix 2.2	RIN, Rout	–0.5	2.5	5.5	dB
Vocal - Mix 3.1	Vmix 3.1	f =100Hz, LIN, Lout	–2.0	1.0	4.0	dB
Vocal - Mix 3.2	Vmix 3.2	RIN, Rout	–2.0	1.0	4.0	dB
Muting Level 1	Vmute1	20 - 20kHz BPF	–	–80.0	–74.0	dB
Muting Level 2	Vmute2	20 - 20kHz BPF	–	–80.0	–74.0	dB
Muting Level 3	Vmute3	20 - 20kHz BPF	–	–80.0	–74.0	dB
Muting Level 4	Vmute4	20 - 20kHz BPF	–	–80.0	–74.0	dB

PIN DESCRIPTION

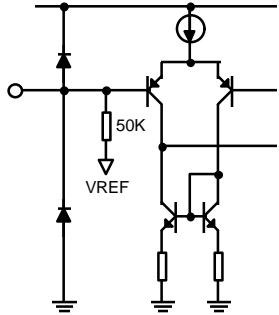
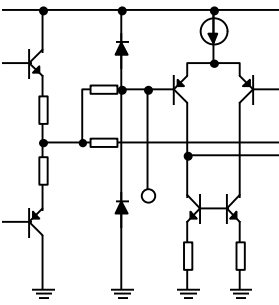
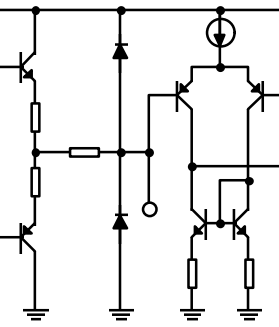
No.	Function	Description	Equivalent Circuit
1 32	LIN RIN	signal Input Port Input Impedence = 50kΩ	
2 3 4 5 6 7	PSN1 PSN2 PSN3 PSN4 PSN5 PSN6	Connected Capacitor for phase shift	
8	V _{CC}		
9	LPF1	Power Supply 9kHz LPF	
10		N.C	

PIN DESCRIPTION (Continued)

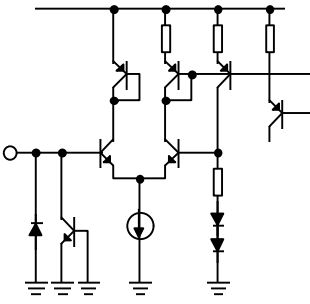
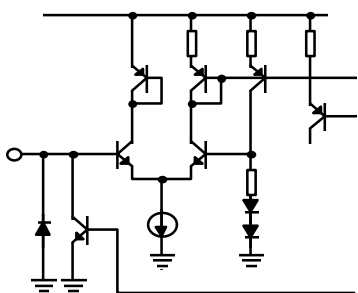
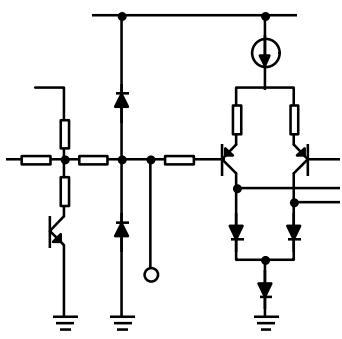
No.	Function	Description	Equivalent Circuit
11	SCL	Serial Clock Input Port	
12	SDA	Serial Data Input Port	
13	VSS	Digital Ground	
14 15 16	WOOC VOLC BALC	Connected capacitor for reducing the shock noise in D/A converter	

PIN DESCRIPTION (Continued)

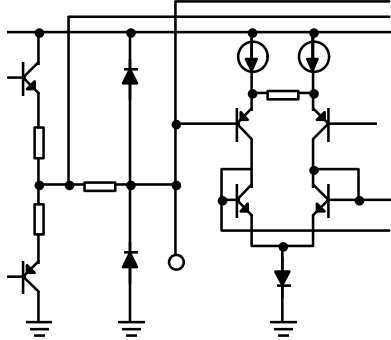
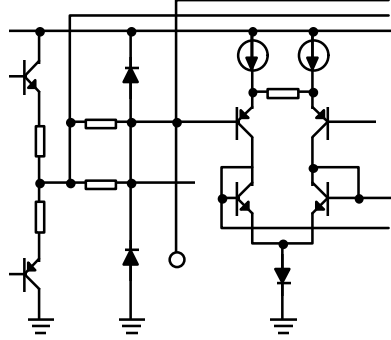
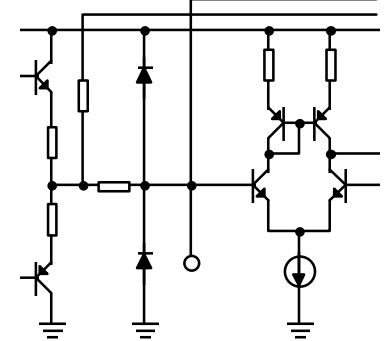
No.	Function	Description	Equivalent Circuit
17 24	TR. R TR. L	Connected Capacitor for boosting/ cutting the treble	
18 23	BA . R BA . L	Connected Capacitor for boosting/ cutting the bass	
19 22	OFCR OFCL	Connected capacitor for eliminating DC offset voltage	

PIN DESCRIPTION (Continued)

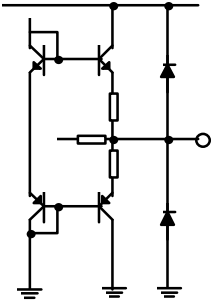
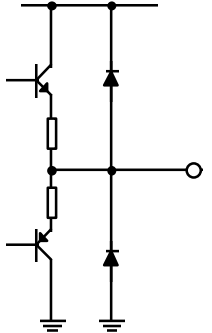
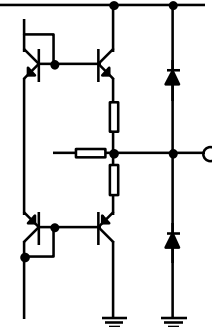
No.	Function	Description	Equivalent Circuit
20 21	ROUT LOUT	Main Output Port	
25	GND	Analog Ground	
26 27	RIOUT LIOUT	Monitor Output Port	
28	REOUT	Rear Output Port	

PIN DESCRIPTION (Continued)

No.	Function	Description	Equivalent Circuit
29 30	WOUT WNF	Woofer Output Port Connected capacitor in Woofer LPF	
31	VBIAS	Biased voltage($V_{CC}/2$)	

TEST CIRCUIT

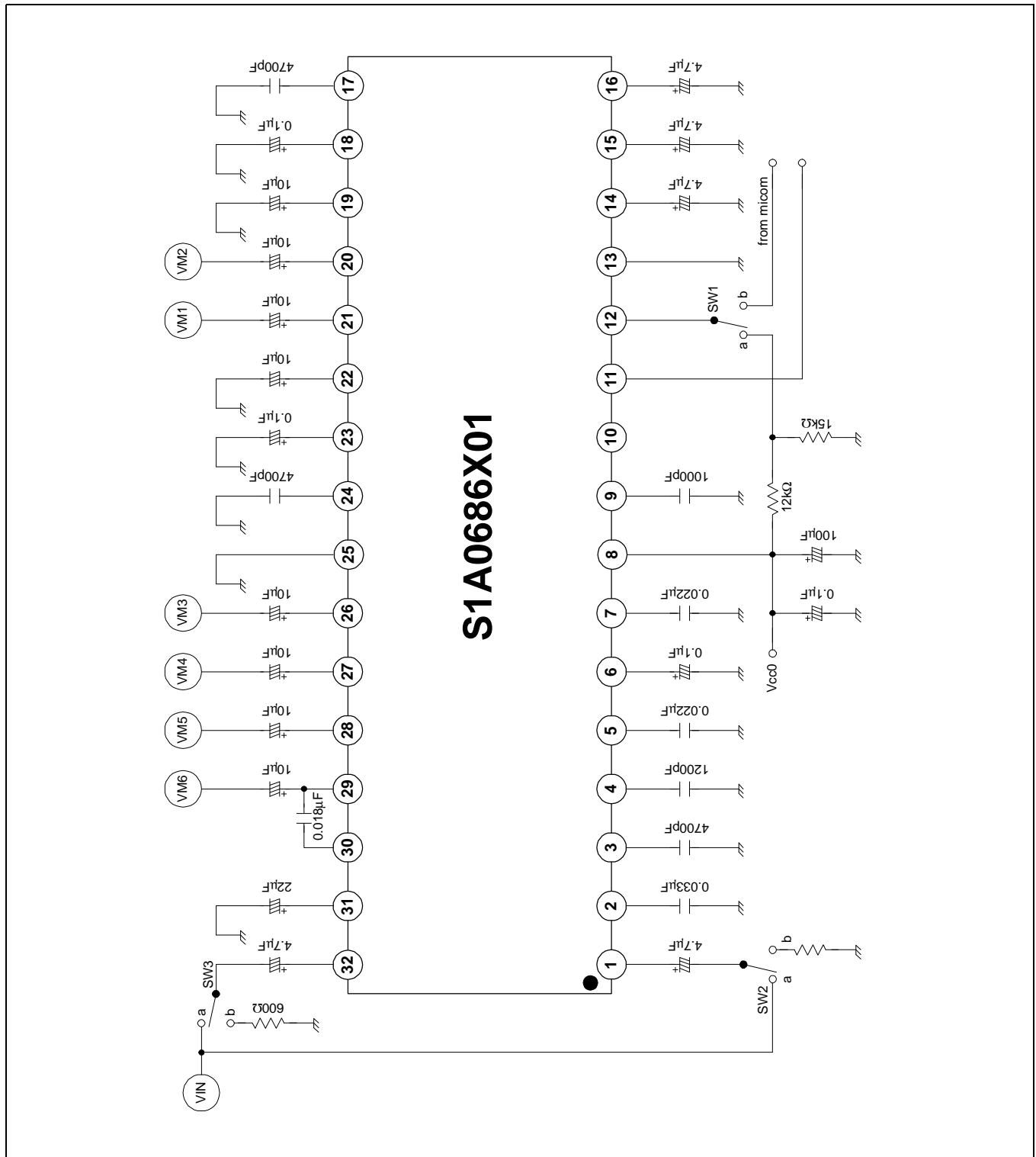

APPLICATION CIRCUIT

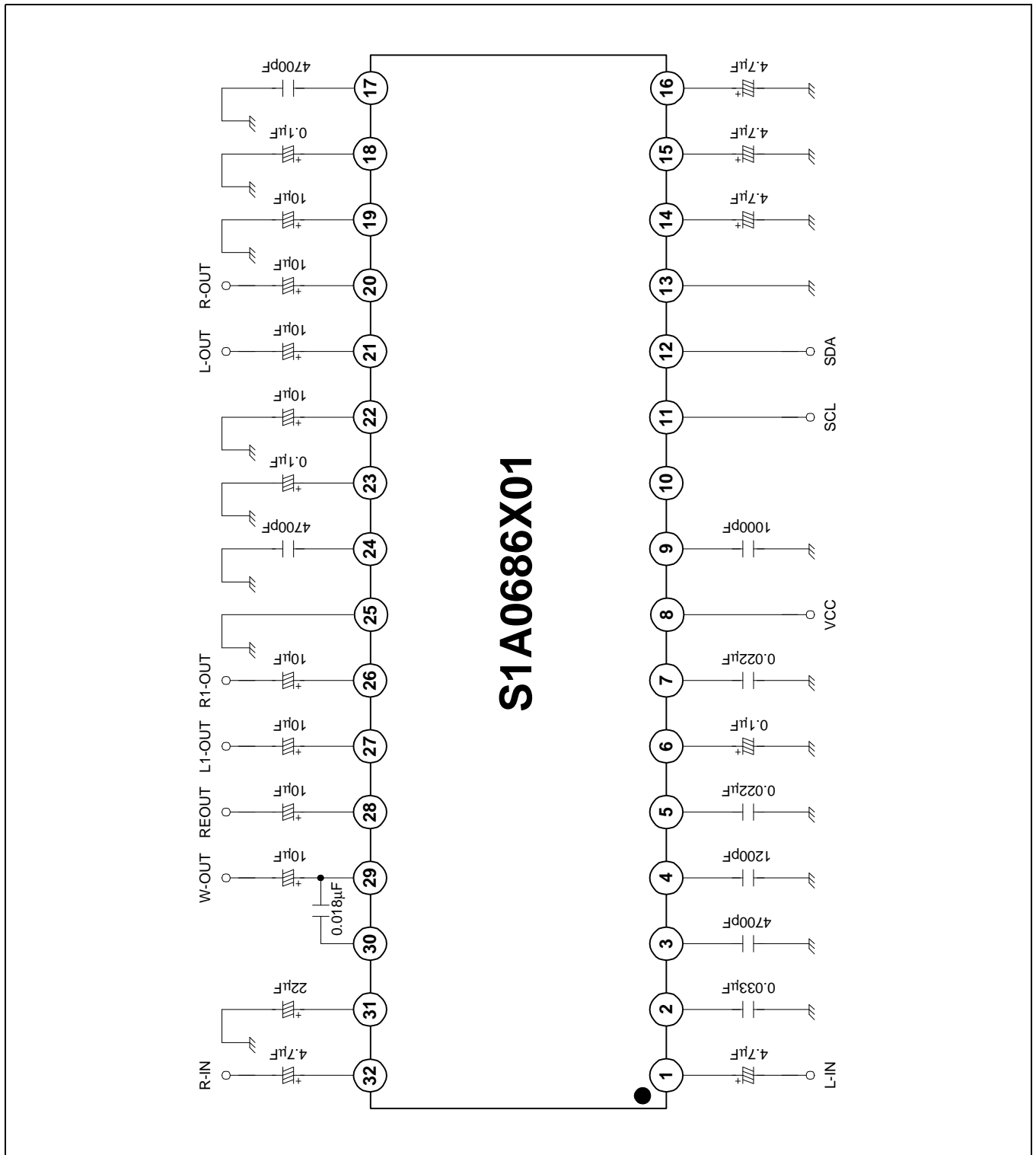

I²C BUS INTERFACE

The S1A0686X01 is controlled by I²C bus of philips. This serial bus (I²C) is composed of 2 wires (SCL, SDA). When the SCL, SDA ports connect to the S1A0686X01, They must be connected to pull-up resistors of positive voltage (5V) like as bellow.

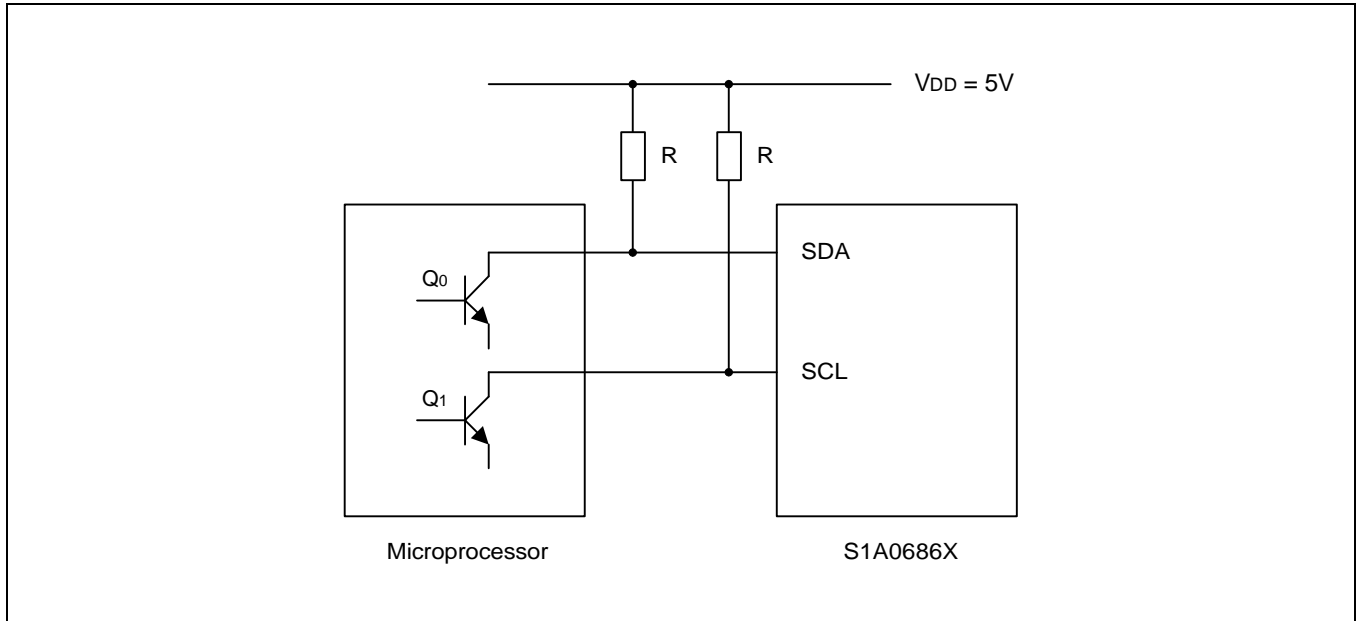

I²C BUS stage outputs digital signal to adjust system control and volume control by decoding of μ - com data SCL, SDA.

From the m-com data, the S1A0686 checks the slave address. If the checked data of slave address is right data of the S1A0686X01, the S1A0686X01 sends out the acknowledge signal to μ - com. And the S1A0686X01 is controlled by data format like of this (START + SLAVE ADDR + SUB ADDR + DATA + STOP), this is single data format. Also this device can be controlled by continual data format without the SUB ADDR.

SINGLE DATA FORMAT (For the each function control)

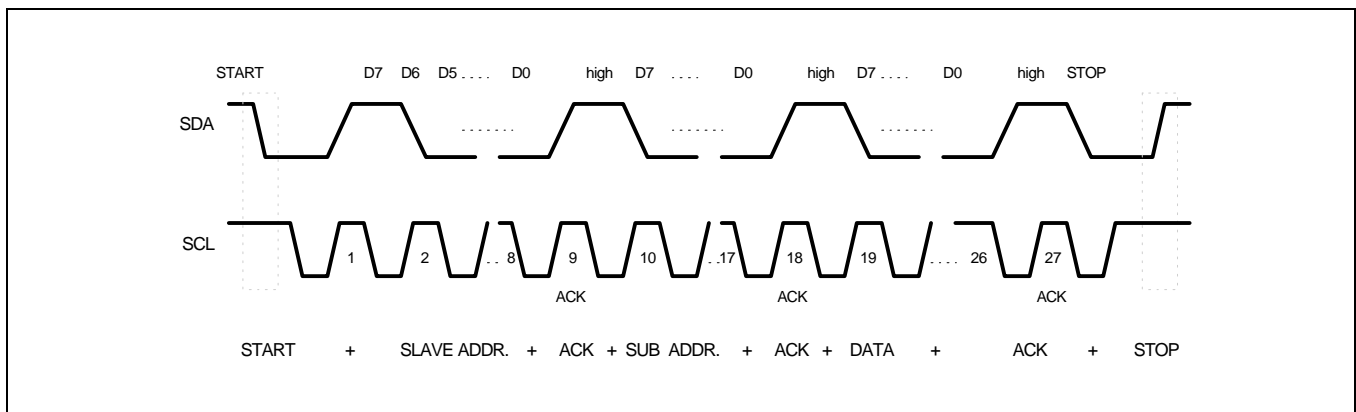

CONTROL DATA FORMAT (For the initial data setting)

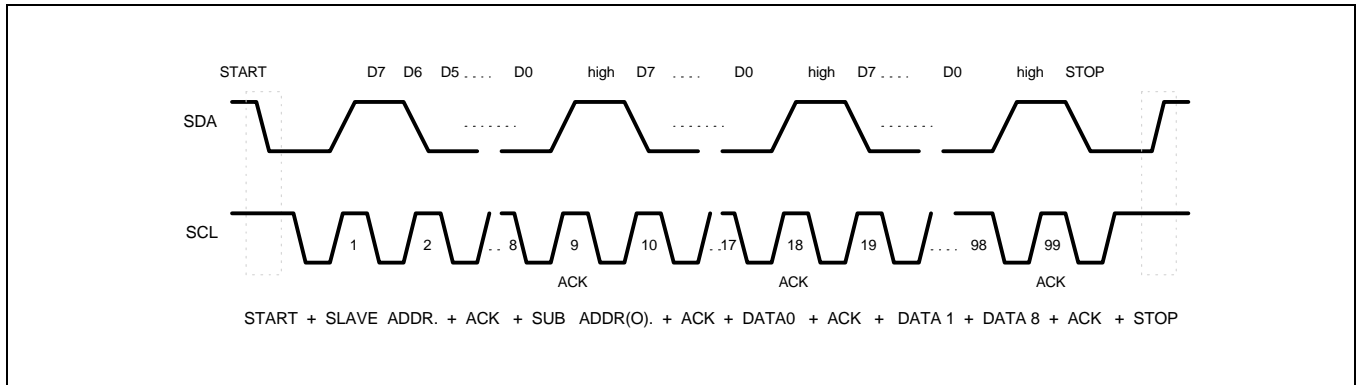

SCL (Serial Clock Line)

The microprocessor outputs serial clock to synchronize with the data.
 According to this clock, the S1A0686X01 takes in the serial data.
 In this case, clock frequency is 0Hz - 100kHz.

SDA (Serial DATA Line)

The microprocessor outputs the data which is synchronized with serial clock.
 The S1A0686X01 takes in this data according to the clock.

Start Condition

Start Condition is made by falling of SDA from “High” to “Low”, during SCL is “High” as shown below.

Stop Condition

Stop Condition is made by rising of SDA from “Low” to “High”, during SCL is “High” as shown below.

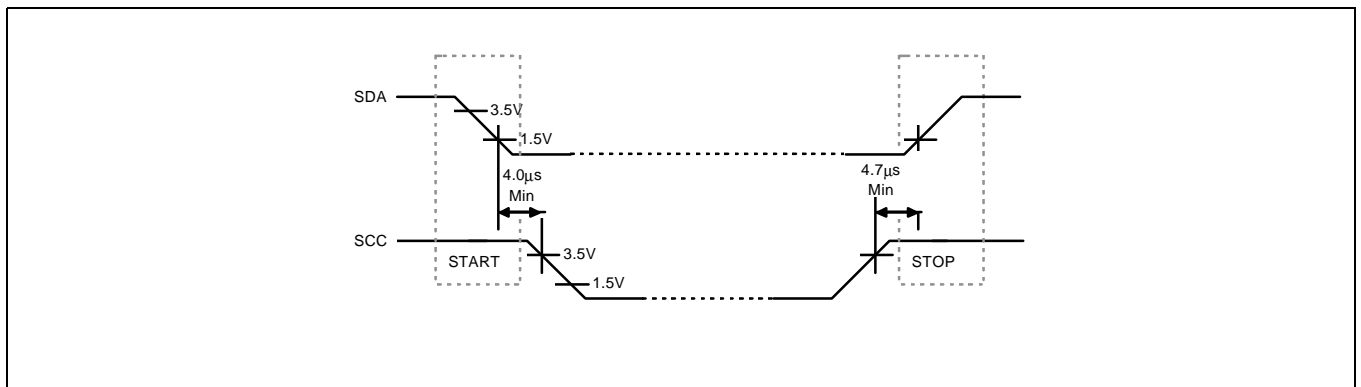

I²C BUS (SUB ADDRESS & DATA ADDRESS) SLAVE ADDRESS = 80H

D7 : Automatic increment off/on

SUB ADDR.	D0	D1	D2	D3	D4	D5	D6	D7	
00H	MAIN MUTE 1/0	WOUT MUTE 1/0	REOUT MUTE 1/0	Monitor Select 1/0	Vocal on/off 1/0	X	X	0	Monitor Select → 0 : direct 1 : Surround & tone & volume VOCAL ON/OFF → I/O
01H	L,R : 1111111 (max) to 0000000 (min)							0/1	Main volume control
02H	L : 111111 (min) to 000001 (flat) to 000000 (flat) R : 111111 (flat) to 000001 (flat) to 000000 (min)						X	0/1	Balance ctrl
03H	L,R : 111111 (boost) to 000001 (flat) to 000000 (cut)						X	0/1	Bass ctrl
04H	L,R : 111111 (boost) to 000001 (flat) to 000000 (cut)						X	0/1	Treble ctrl
05H	W : 111111 (max) to 000000 (min)						X	0/1	Woofer vol ctrl
06H	RE : 111111 (max) to 000000 (min)						X	0/1	Rear vol ctrl
07H	E : 1111 (max) to 0000 (min)				M : 00 to 11		X	0/1	Effect ctrl + mode ctrl
08H	V : 1111 (max) to 0000 (min)				X	X	X	0/1	Vocal mix ctrl

X : don't care

SURROUND PROCESSOR

1) OFF MODE :

Inputed signal sends out the outputs without the surround effect.

MICOM DATA →

SLAVE ADDR.	SUB ADDR.	DATA
80H	07H	XX00XXXX

< OFF MODE : LIN, RIN ® LOUT, ROUT >

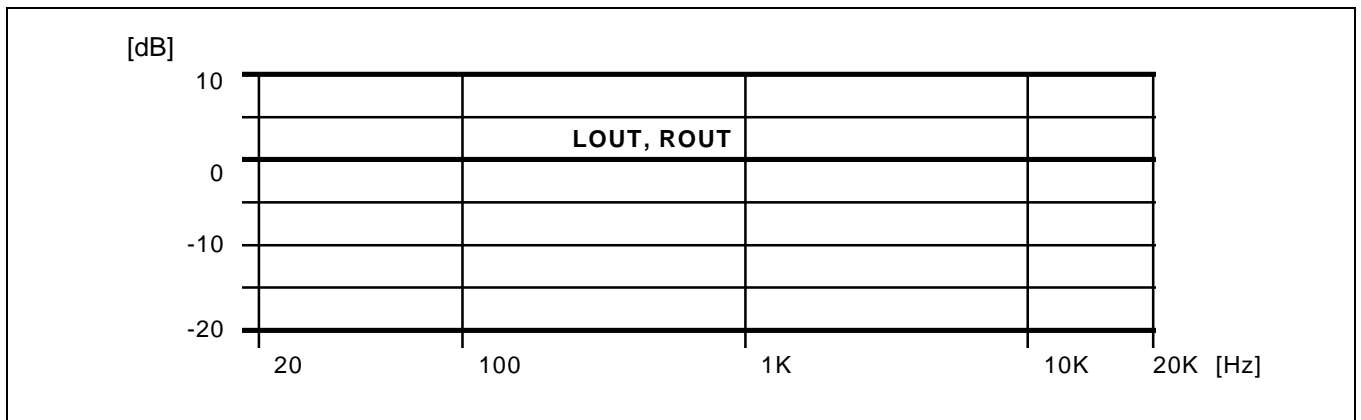

2) MUSIC MODE

This mode is for the HALL sound effect when the input sound is stereo. After selecting the music mode, controls the effect part. And then you will get the special frequency characteristics. (Emphasize the middle and high sound, cut the low sound)

Simultaneously, you can control vocal-mix for the vocal sound emphasis.

MICOM DATA →

SLAVE ADDR.	SUB ADDR.	DATA
80H	07H	XX01XXXX

< MUSIC MODE : LIN ® LOUT, ROUT EFFECT MAX, VOCAL_MIX MIN >

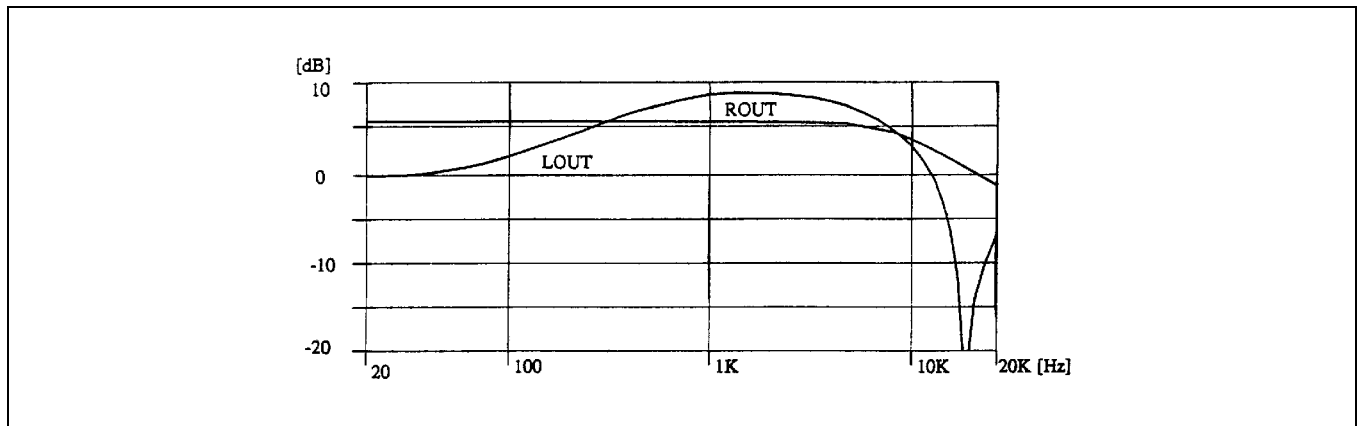

3) MOVIE MODE :

This mode is for the picture hall effect when the input sound is stereo. After selecting the movie mode, controls the effect part. And then you will get the special frequency characteristics (Emphasize the low and middle sound) Simultaneously, you can control vocal-mix for the vocal sound emphasis.

MICOM DATA →	SLAVE ADDR.	SUB ADDR.	DATA
	80H	07H	XX10XXXX

< MOVIE MODE: LIN LOUT, ROUT, EFFECT MAX, VOCAL_MIX MIN >

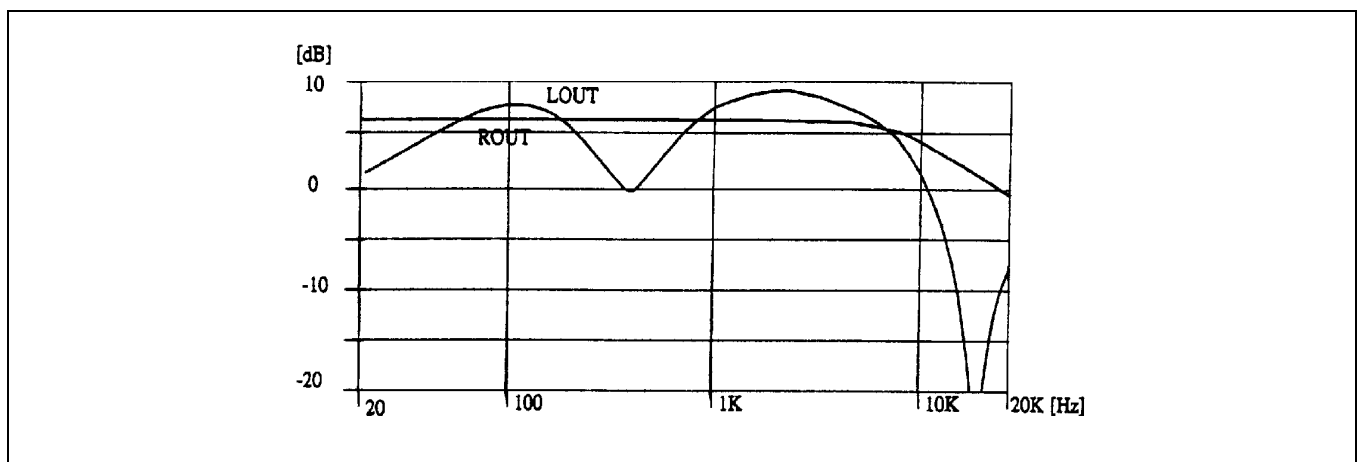

4) SIMULATED MODE :

This mode is for the getting pseudo stereo effect when the input is mono signal. From using the phase shifter, you can control the gain and phase of some frequency. It means that you can get the stereo effect from the gain in mono sound.

Also you can control effect part and vocal-mix part.

MICOM DATA →

SLAVE ADDR.	SUB ADDR.	DATA
80H	07H	XX11XXXX

< SIMULATED MODE : LIN, RIN ® LOUT, ROUT EFFECT MAX, VOCAL_MIX MIN >

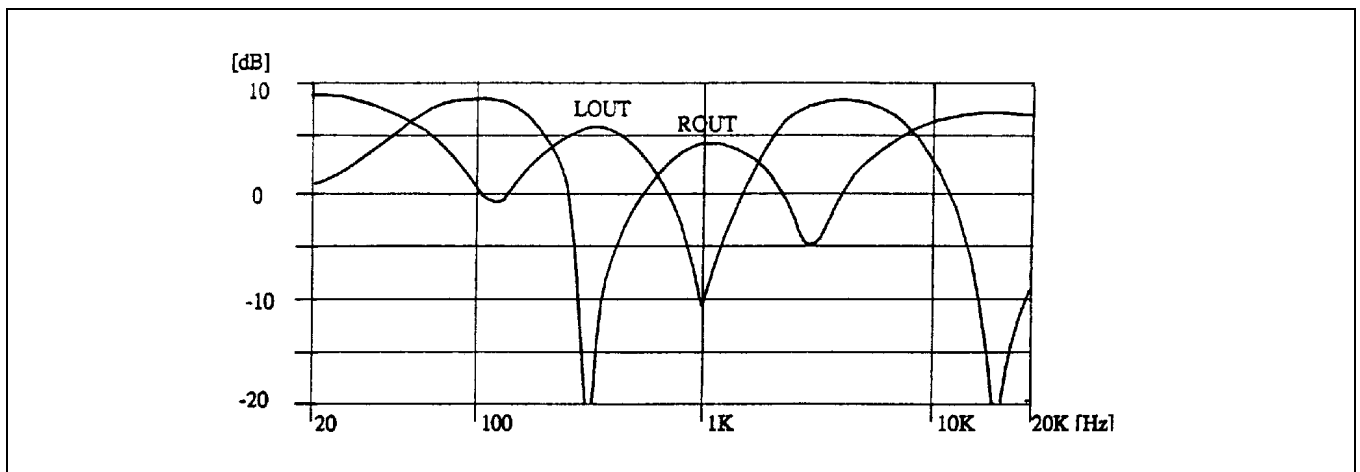

5) VOCAL - MIX

After the setting the initial data of vocal-mix. Just selects the vocal on. And then you will get the emphasized vocal sound in every mode.

MICOM DATA →

SLAVE ADDR.	SUB ADDR.	DATA
80H	08H	XXXXd3d21d0

d3d2d1d0 → 1111 (max), 0000 (min)

MICOM DATA →

SLAVE ADDR.	SUB ADDR.	DATA
80H	00H	XXXXd3XXX

d3 → 1 : VOCAL ON, 0 : VOCAL OFF

<LIN, RIN ® LOUT, ROUT (OFF MODE, VOCAL_MIX MAX)

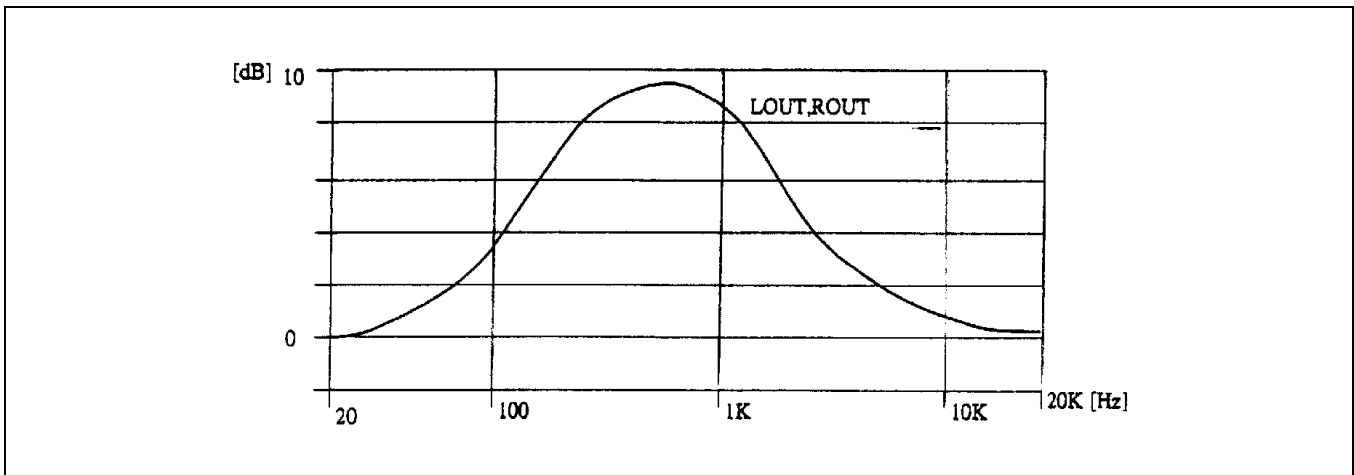

6) MONITOR OUTPUT SELECT

This mode selects the monitor output

MICOM DATA →

SLAVE ADDR.	SUB ADDR.	DATA
80H	00H	XXXXd3XXX

MONITOR SELECT: DATA = 0, L1OUT = LIN, R1OUT = RIN
 1, L1OUT = LOUT, R1OUT = ROUT

7) VOLUME CONTROL

This block is for the control of signal level from the surround processor output.

(1). Tone (BASS, TREBLE) Control

It control the tone characteristics of main channel.

MICOM DATA →

SLAVE ADDR.	SUB ADDR.	DATA
80H	03H	XXd5.....d0

(BASS)

MICOM DATA →

SLAVE ADDR.	SUB ADDR.	DATA
80H	04H	XXd5.....d0

(TREBLE)

BASS, TREBLE Control ; DATA =
 000000 (CUT) → 100000 (FLAT) → 111111 (BOOST)

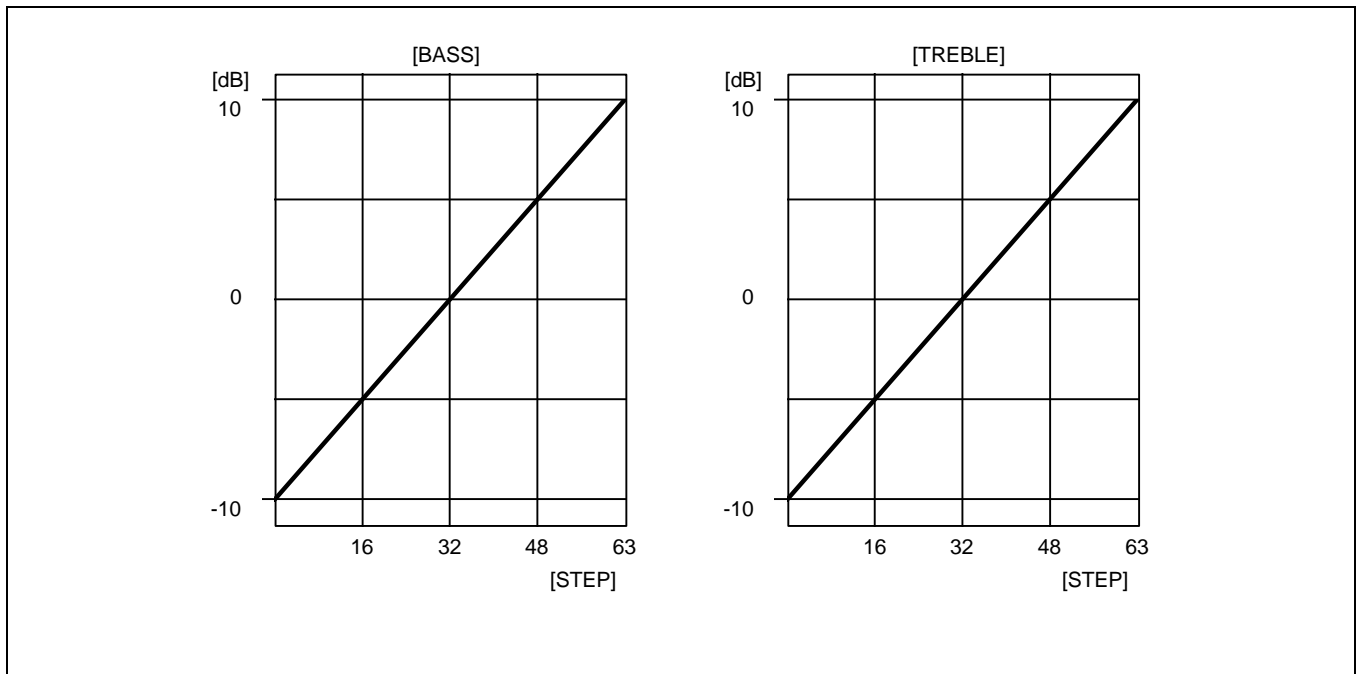

8) MAIN VOLUME CONTROL

It controls the volume of L, R output in main channel.

MICOM DATA →
(VOLUME)

SLAVE ADDR.	SUB ADDR.	DATA
80H	01H	Xd6.....d0

VOLUME CONTROL : DATA = 000000, VOLUME MIN
= 111111, VOLUME MAX

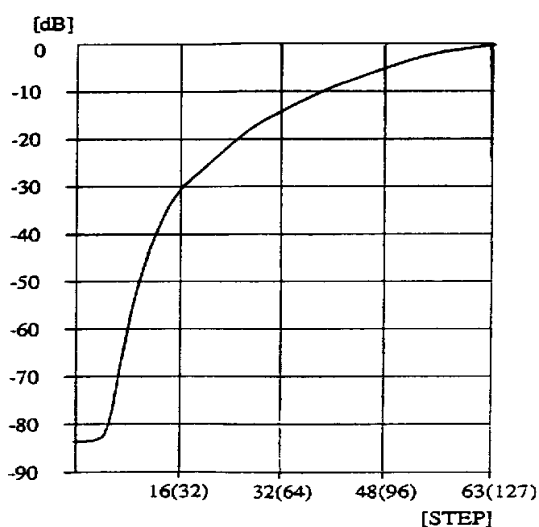

** You can control the volume step to 127 and 63 to adjust the volume control bits (7 bit, 6 bit)

(3) BALANCE CONTROL

When the balance up, decrease the L output
When the balance down, decrease the R output

MICOM DATA →

SLAVE ADDR.	SUB ADDR.	DATA
80H	02H	XXd5.....d0

BALANCE CONTROL : DATA = 000000, ROUT MIN (LOUT FLAT)
= 100000, LOUT = ROUT (Center)
= 111111, LOUT MIN (ROUT FLAT)

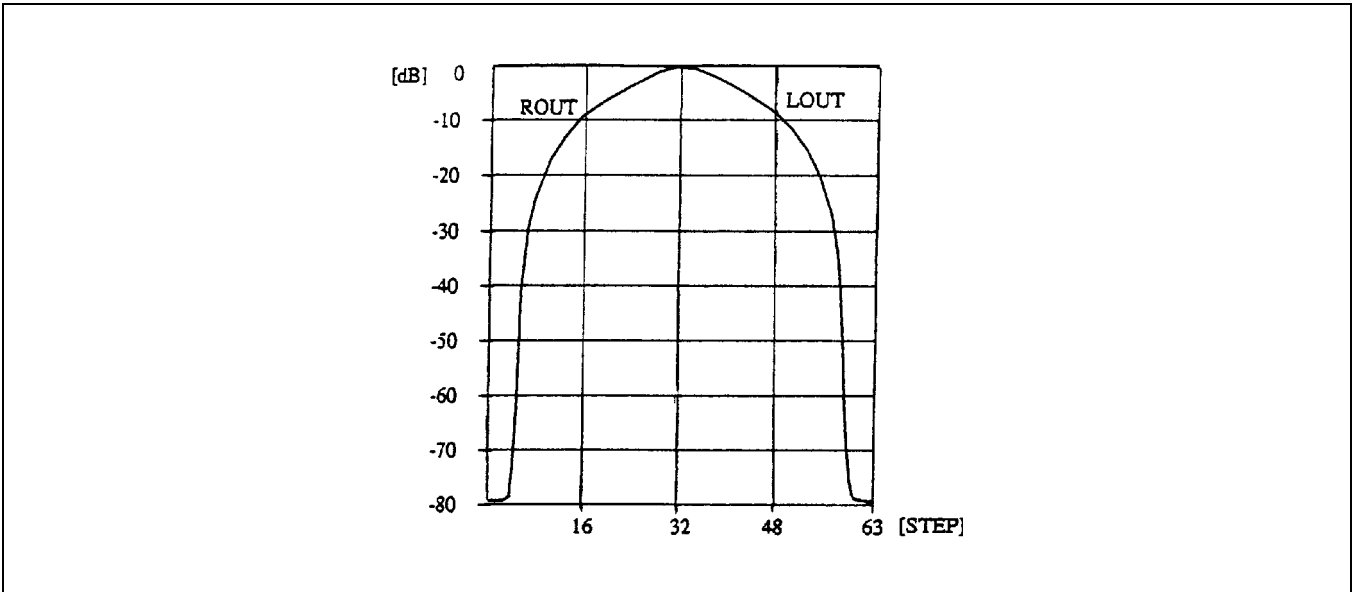

(4) REAR VOLUME CONTROL :

MICOM DATA →
(VOLUME)

SLAVE ADDR.	SUB ADDR.	DATA
80H	06H	XXd5.....d0

REAR VOLUME CONTROL : DATA = 000000, MIN
= 1111111, MAX = 111111, MAX

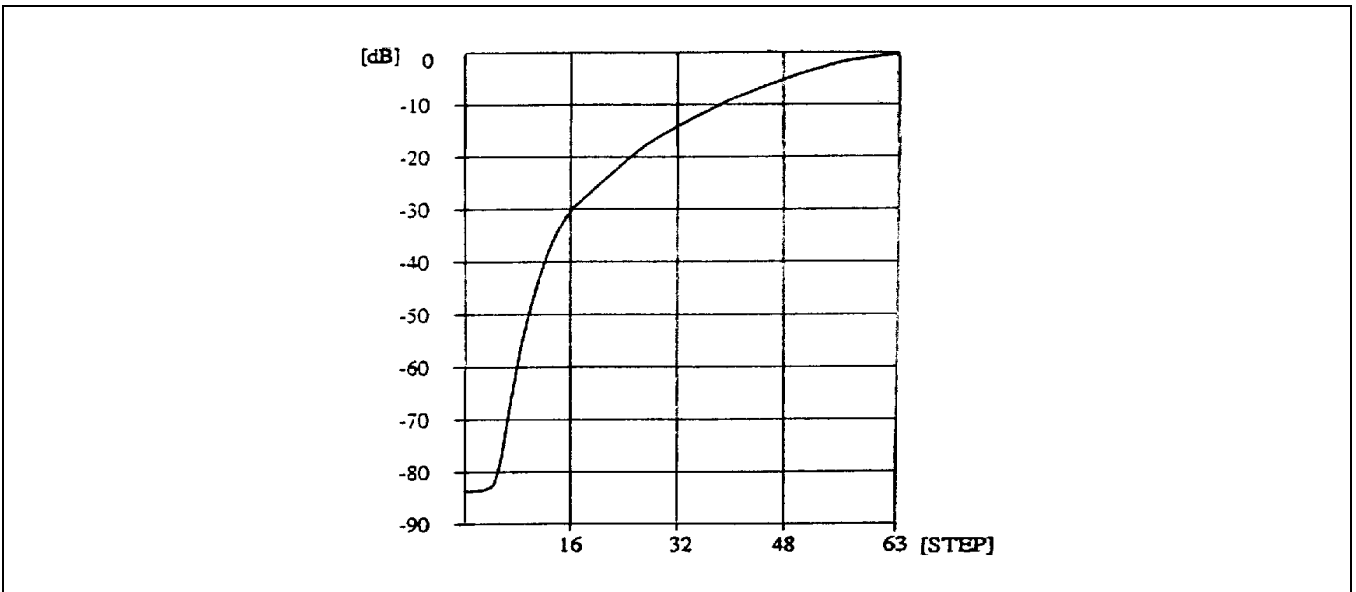

(5) WOOFER VOLUME CONTROL : WOOFER VOLUME CONTROL

MICOM DATA →
(VOLUME)

SLAVE ADDR.	SUB ADDR.	DATA
80H	05H	XXd5.....d0

WOOFER VOLUME CONTROL : DATA = 000000, MIN
= 1111111, MAX = 111111, MAX

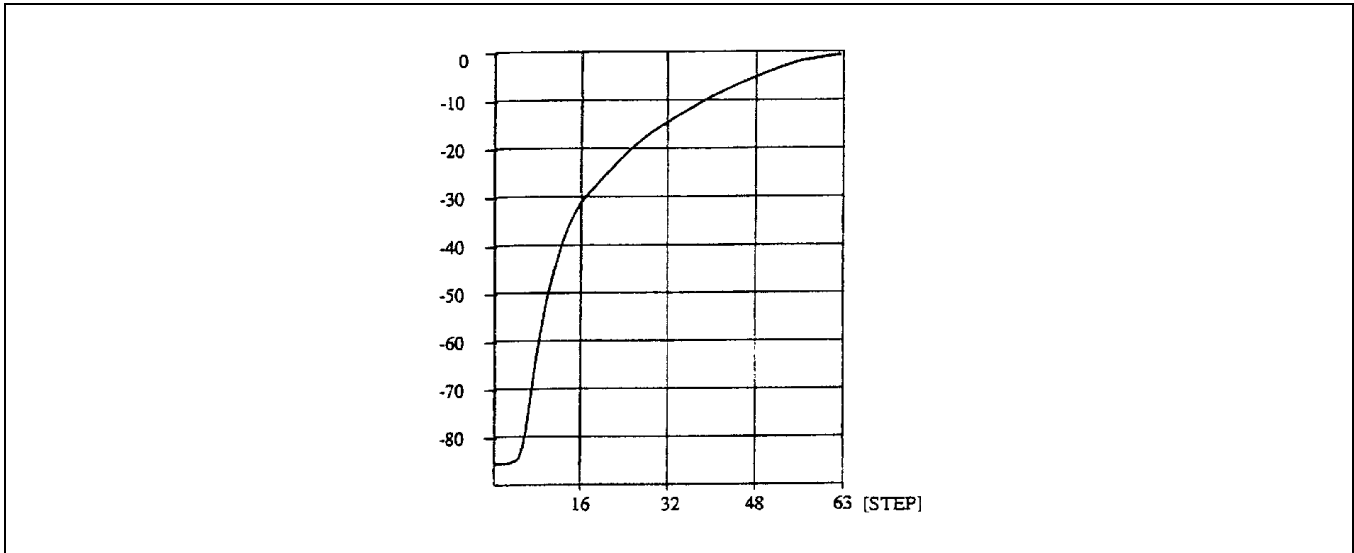

(6) WOOFER LPF CHARACTERISTICS

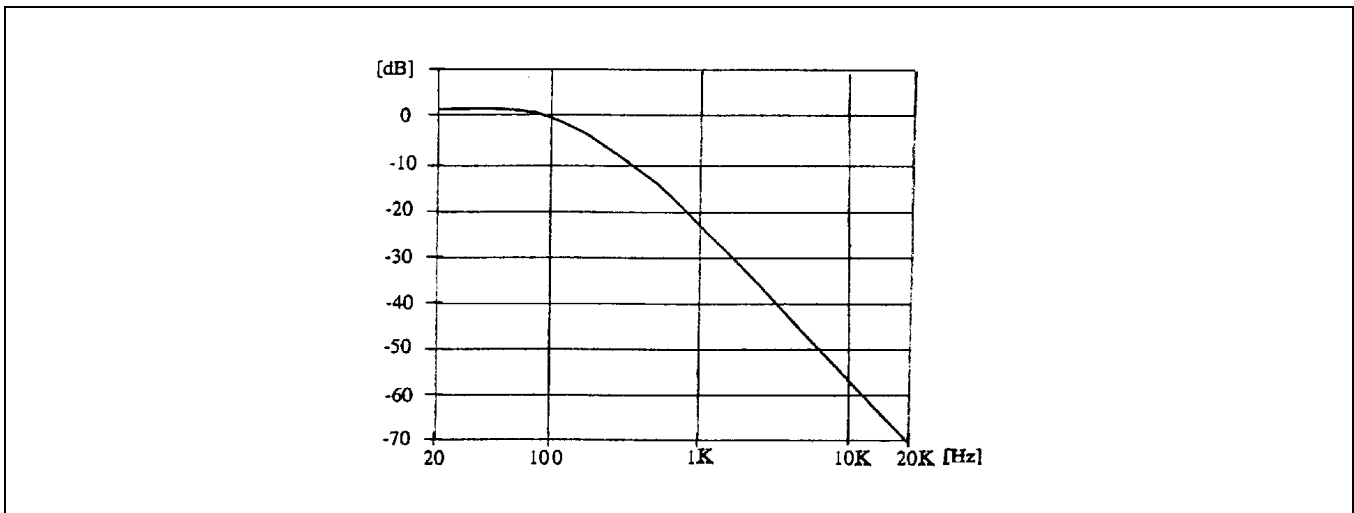

(7) MUTING CONTROL :

You can control the muting of main volume, rear volume woofer volume.

MICOM DATA →	SLAVE ADDR.	SUB ADDR.	DATA
	80H	00H	XXXXXd2d1d0

MAIN VOLUME MUTING : DATA (d0) = 1 / 0 (ON / OFF)

WOOFER VOLUME MUTING : DATA (d1) = 1 / 0 (ON / OFF)

REAR VOLUME MUTING : DATA (d2) = 1 / 0 (ON / OFF)

PROGRAM CONTROL MATHOD:

1) INSTALL: RUN KB22686.EXE

2) KEYBOARD SETUP:

[NUMBER LOCK] --- OFF , [CAPS LOCK] --- ON

3) CONTROL MODE AND METHOD:

ACCORDING TO HELP MASSAGE ON SCREEN

4) EXIT:

CAP LOCK OFF , ALT+ ESC.

NOTES