

Triple Linear Regulator Controller Support ACPI Control Interface

General Description

The RT9641A/B, paired with either the RT9230 or RT9231 simplifies the implementation of ACPI-compliant designs in microprocessor and computer applications. The IC integrates two linear controllers and a low-current pass transistor, as well as the monitoring and control functions into a 16-pin SOIC package. One linear controller generates the 3.3V_{DUAL} voltage plane from an ATX power supply's 5VSB output during sleep states (S3,S4/S5), powering the PCI slots through an external pass transistor, as instructed by the status of the 3.3V_{DUAL} enable pin. An additional pass transistor is used to switch in the ATX 3.3V output for PCI operation during S0 and S1 (active) operating states. The second linear controller supplies the computer system's 2.5V/3.3V memory power through an external pass transistor in active states. During S3 state, an integrated pass transistor supplies the 2.5V/3.3V sleep-state power. A third controller powers up a 5V_{DUAL} plane by switching in the ATX 5V output in active states, or the ATX 5VSB in sleep states.

The RT9641A/B's operating mode (active-state outputs or sleep-state outputs) is selectable through two control pins: $\overline{S3}$ and $\overline{S5}$. Further control of the logic governing activation of different power modes is offered through two enabling pins: EN3VDL and $\overline{EN5VDL}$. In active states, the 3.3V_{DUAL} linear regulator uses an external N-channel pass MOSFET to connect the output (V_{OUT1}) directly to the 3.3V input supplied by an ATX (or equivalent) power supply, while incurring minimal losses. In sleep state, the 3.3V_{DUAL} output is supplied from the ATX 5VSB through a NPN transistor, also external to the controller. Active state power delivery for the 2.5V/3.3V or 2.6V/3.43V V_{MEM} output is done through an external NPN or a NMOS transistor. In sleep states, conduction on this output is transferred to an internal pass transistor. The 5V_{DUAL} output is powered through two external MOS transistors. In sleep states, a PMOS (or PNP) transistor conducts the current from the ATX 5VSB output, while in active states, current flow is transferred to a NMOS transistor connected to the ATX 5V output. Similar to the 3.3V_{DUAL} output, the operation of the 5V_{DUAL} output is dictated not only by the status of the $\overline{S3}$ and $\overline{S5}$ pins, but that of the EN5VDL pin as well.

Features

- **Provides 3 ACPI-Controlled Voltages**
 - 5V Active/Sleep(5V_{DUAL})
 - 3.3V Active/Sleep(3.3V_{DUAL})
 - 2.5V/3.3V Active/Sleep(V_{MEM}) with RT9641A
 - 2V/3.43V Active and 2.5V/3.3V Sleep(V_{MEM}) with RT9641B
- **Simple Control Design**
 - No Compensation Required
- **Excellent Output Voltage Accuracy**
 - 3.3V_{DUAL} Output : $\pm 2.0\%$; Sleep States Only
 - 2.5V/3.3V (2.6V/3.43V) Output : $\pm 2.0\%$; Both Operational States
- **Fixed Output Voltages Require No Precision External Resistors**
- **Small Size**
 - Small External Component Count
- **Selectable 2.5V/3.3V (2.6/3.43) V_{MEM} Output Voltage via FAULT/MSEL Pin**
 - 2.5V/2.6V for RDRAM Memory
 - 3.3V/3.43V for SDRAM Memory
- **Under-voltage Monitoring of All Outputs with Centralized FAULT Reporting**
- **Adjustable Soft-start Function Eliminates 5VSB Perturbations**

Ordering Information

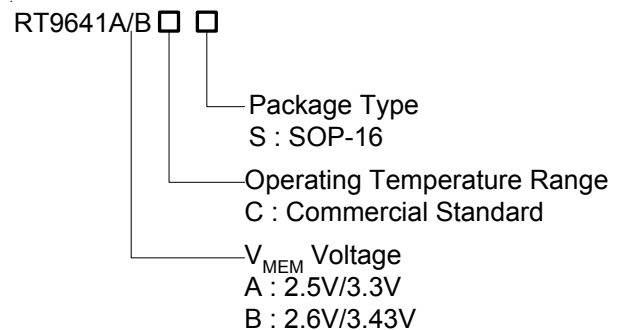

Pin Configurations

TOP VIEW

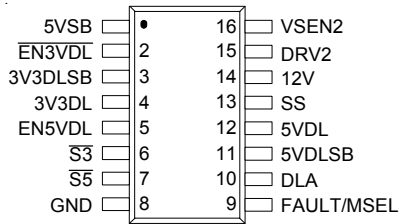

SOP-16 Package

Typical Application Circuit

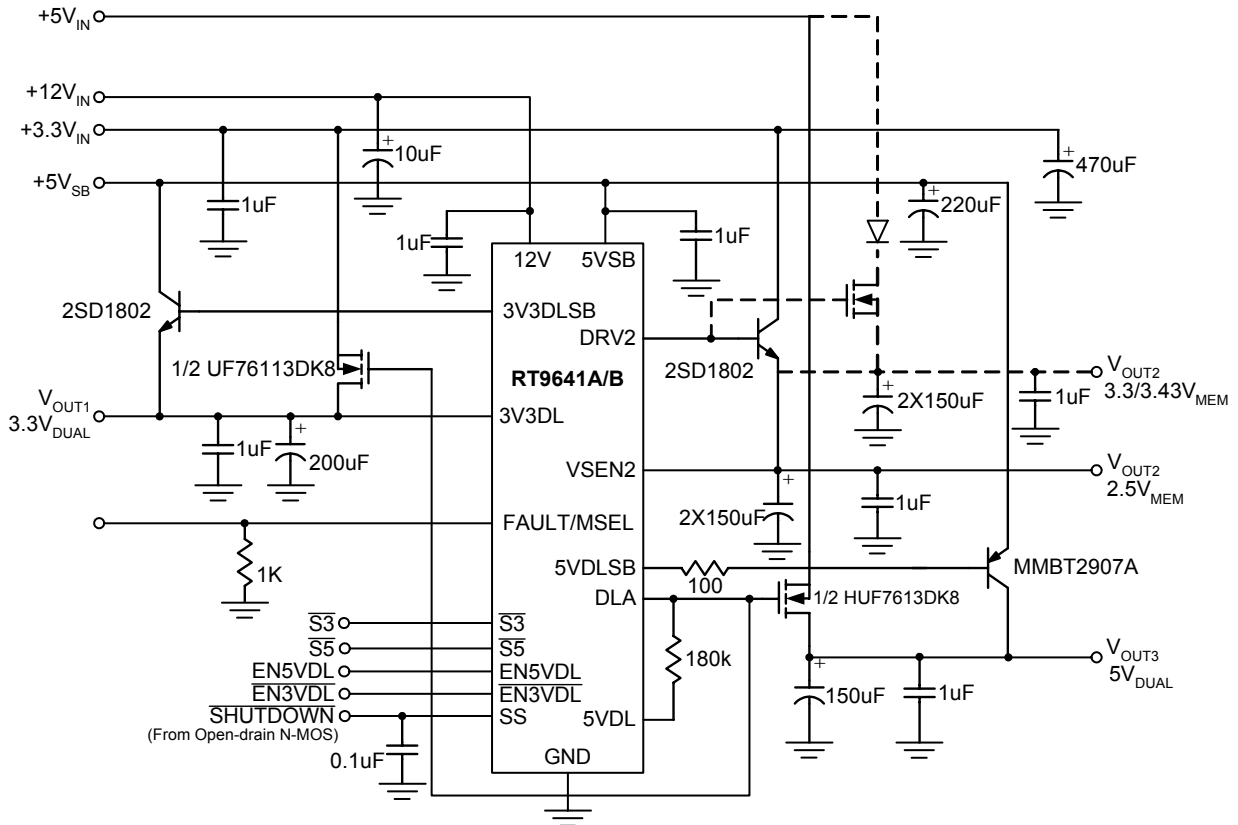

Function Block Diagram

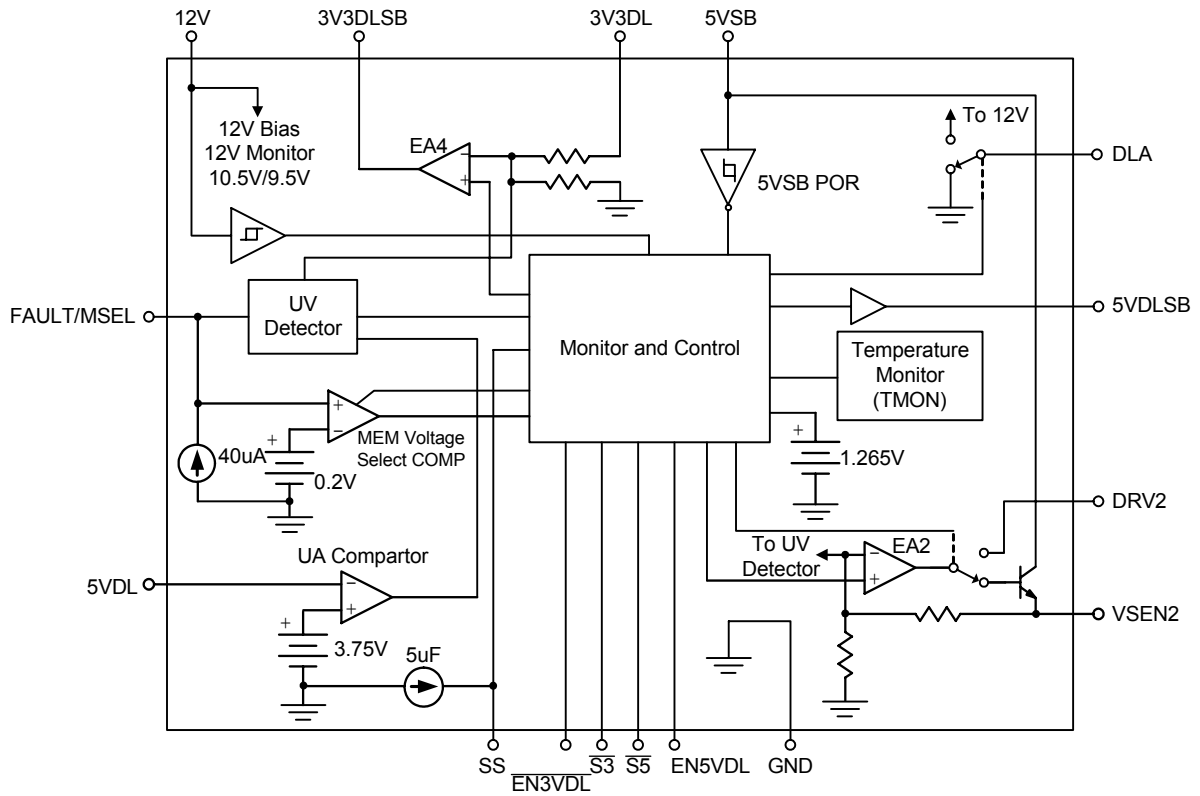

Simplified Power System Diagram

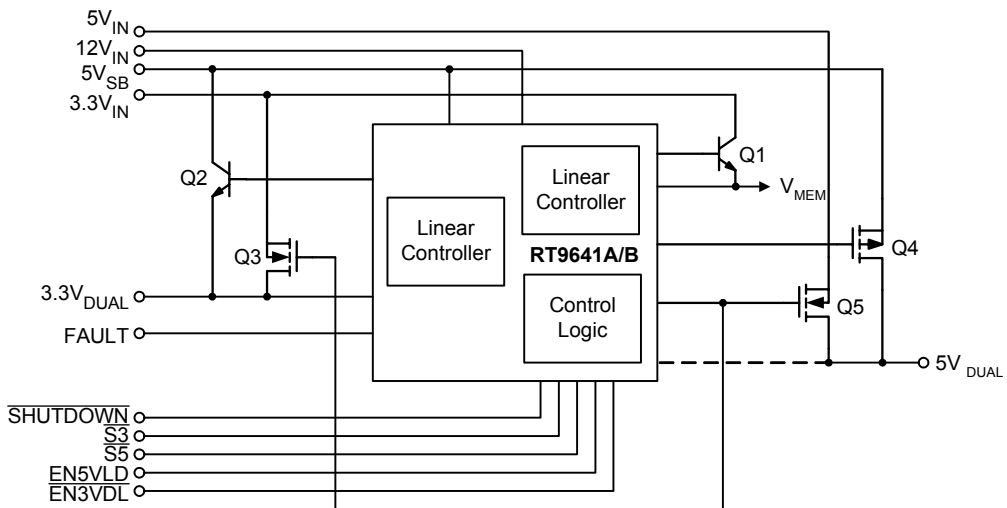

Absolute Maximum Ratings

- Supply Voltage (V_{5VSB}) ----- +7.0V
- 12V ----- GND-0.3V to +14.5V
- DLA, DRV2 ----- GND-0.3V to $V_{12V}+0.3V$
- All Other Pins ----- GND-0.3V to $5VSB+0.3V$
- Package Thermal Resistance
- SOP-16, θ_{JA} ----- 100° C/W
- Maximum Junction Temperature ----- 150° C
- Maximum Storage Temperature Range ----- -65° C to 150° C
- Maximum Lead Temperature (Soldering, 10 sec.) ----- 300° C

Recommended Operating Conditions

- Supply Voltage (V_{5VSB}) ----- +5V $\pm 5\%$
- Secondary Bias Voltage (V_{12V}) ----- +12V $\pm 10\%$
- Digital Inputs (V_{S3} , V_{S5} , V_{EN3VDL} , V_{EN5VDL}) ----- 0 to +5.5V
- Junction Temperature Range ----- 0° C to 125° C
- Ambient Temperature Range ----- 0° C to 70° C

CAUTION:

Stresses beyond the ratings specified in "Absolute Maximum Ratings" may cause permanent damage to the device. This is a stress only rating and operation of the device at these or any other conditions above those indicated in the operational sections of this specification is not implied.

Electrical Characteristics

(V_{CC} ($12V_{IN}$) = 12V, GND = 0V, T_A = 25° C, unless otherwise specified)

| Parameter | Symbol | Test Conditions | Min | Typ | Max | Units |
|--|-----------------|---|-----|------|-----|---------|
| VCC Supply Current | | | | | | |
| Operating Supply Current | I_{5VSB} | | -- | 7 | 20 | mA |
| Shutdown Supply Current | $I_{5VSB(OFF)}$ | $V_{SS} = 0V, \overline{S3} = 0, \overline{S5} = 0$ | -- | 2 | 10 | mA |
| Power-on Reset, Soft-start, and 12V Monitor | | | | | | |
| Rising 5VSB POR Threshold | | | -- | 2.5 | -- | V |
| Rising 12V Threshold | | | -- | 10.5 | 11 | V |
| Soft-start Current | I_{SS} | | -- | 6.5 | -- | μA |
| Shutdown Soft-start Voltage | | | -- | 0.8 | -- | V |

To be continued

| Parameter | Symbol | Test Conditions | Min | Typ | Max | Units |
|--|----------------------|--|-----|-------------------|-----|-------|
| 2.5V/3.3V (2.6V/3.43V) Linear Regulator (V_{OUT2}) | | | | | | |
| Regulation | | | -- | -- | 2.0 | % |
| VSEN2 Nominal Voltage Level | V _{VSEN} | R _{SEL} = 1kΩ | -- | 2.5/2.6 | -- | V |
| VSEN2 Nominal Voltage Level | V _{VSEN2} | R _{SEL} = 1kΩ | -- | 3.3/3.4 | -- | V |
| VSEN2 Under-voltage Falling Threshold | | | -- | 68 | -- | % |
| VSEN2 Under-voltage Hysteresis | | | -- | 7 | -- | % |
| VSEN2 Output Current | I _{VSEN2} | 5VSB = 5V | 200 | 300 | -- | mA |
| DRV2 Output Drive Current | I _{DRV2} | 5VSB = 5V, R _{SEL} = 1kΩ | 20 | 30 | -- | mA |
| DRV2 Output Impedance | | R _{SEL} = 10kΩ | -- | 200 | -- | Ω |
| 3.3V Dual Linear Regulator (V_{OUT1}) | | | | | | |
| Sleep-mode Regulation | | | -- | -- | 2.0 | % |
| 3V3DL Nominal Voltage Level | V _{3V3DL} | | -- | 3.3 | -- | V |
| 3V3DL Under-voltage Falling Threshold | | | -- | 2.24 | -- | V |
| 3V3DL Under-voltage Hysteresis | | | -- | 230 | -- | mV |
| 3V3DLSB Output Drive Current | I _{3V3DLSB} | 5VSB = 5V | 5.0 | 10 | -- | mA |
| DLA Output Impedance | | | -- | 90 | -- | Ω |
| 5V Dual Switch Controller (V_{OUT3}) | | | | | | |
| 5VDL Under-voltage Falling Threshold | | | -- | 3.40 | -- | V |
| 5VDL Under-voltage Hysteresis | | | -- | 350 | -- | mV |
| 5VDLSB Output Drive Current | I _{5VDLSB} | 5VDLSB = 4V | -40 | -- | -- | mA |
| Timing Intervals | | | | | | |
| Active to Sleep, Input to Switching Delay | T _{d1} | | -- | 10 | -- | μS |
| Sleep to Active, Input to Switching Delay | T _{d2} | C _{SS} = 0.1μF ⁽¹⁾ | -- | 50 ⁽¹⁾ | -- | mS |
| Control I/O (S₃, S₅, EN3VDL, EN5VDL, FAULT) | | | | | | |
| High Level Threshold | | | 2.0 | -- | -- | V |
| Low Level Threshold | | | -- | -- | 0.8 | V |
| S ₃ , S ₅ Internal Pull-up Impedance to 5VSB | | | -- | 50 | -- | kΩ |
| FAULT Output Impedance | | FAULT = high | -- | 100 | -- | Ω |
| Temperature Monitor | | | | | | |
| Fault-level Threshold | | | -- | 145 | -- | °C |
| Shutdown-level Threshold | T _{DS} | | -- | 155 | -- | °C |

Note: ⁽¹⁾ = 50mS with 0.1μF Soft-start capacitor. The delay time is adjustable with t_{d2} = 500xC_{SS} (ms).

Functional Pin Description

5VSB (Pin 1)

Provide a 5V bias supply for the IC to this pin by connecting it to the ATX 5VSB output. This pin also provides the base bias current for all the external NPN transistors controlled by the IC. The voltage at this pin monitored for power-on reset (POR) purposes.

$\overline{\text{EN3VDL}}$ and $\overline{\text{EN5VDL}}$ (Pin 2 and 5)

These pins control the logic governing the output behavior in response to S3 and S4/S5 requests. These are digital inputs whose status can only be changed during active states operation or during chip shutdown (SS pin grounded by external open-drain device). The input information is latched-in when entering a sleep state, as well as following 5VSB POR release or exit from shutdown.

3V3DLSB (Pin 3)

Connect this pin to the base of a suitable NPN transistor. In sleep states, this transistor is used to regulate the voltage at 3V3DL pin to 3.3V.

3V3DL (Pin 4)

Connect this pin to the 3.3V dual output (V_{OUT1}). In sleep states, the voltage at this pin is regulated to 3.3V; in active states, ATX 3.3V output is delivered to this node through a fully on N-MOS transistor. During all operating states, this pin is monitored for under-voltage events.

$\overline{\text{S3}}$ and $\overline{\text{S5}}$ (Pin 6 and 7)

These pins switch the IC's operating state from active (S0, S1) to S3 and S4/S5 sleep states. Connect $\overline{\text{S3}}$ to $\overline{\text{SLP_S3}}$ and $\overline{\text{S5}}$ to $\overline{\text{SLP_S5}}$. These are digital inputs featuring internal 50k Ω (typical) resistor pull-up to 5VSB. Internal circuitry de-glitches the S3 pin for disturbances.

GND (Pin 8)

Signal ground for the IC. All voltage levels are measured with respect to this pin.

FAULT/MSEL (Pin 9)

This is a multiplexed function pin allowing the setting of the memory output voltage to either 2.5V(2.6V) or 3.3V(3.43V) (for RDRAM or SDRAM memory systems). The memory voltage setting is latched-in when SS pin voltage goes up to 0.8V (typically 5ms after POR). In case of an under-voltage on any of the outputs or an over temperature event, this pin is used to report the fault

condition by being pulled to 5VSB.

DLA (Pin 10)

Connect this pin to the gates of suitable N-MOSFETs, which in active states, are used to switch in the ATX 3.3V and 5V outputs into the 3.3V_{DUAL} and 5V_{DUAL} outputs, respectively.

5VDLSB (Pin 11)

Connect this pin to the gate of a suitable P-MOSFET or bipolar PNP. In sleep states, this transistor is switched on, connecting the ATX 5VSB output to the 5V_{DUAL} regulator output. When PNP is used, it is recommended to use a 100 Ω base resistor for base current limiting.

5VDL (Pin 12)

Connect this pin to the 5V_{DUAL} output (V_{OUT3}). In either operating state, the voltage at this pin is provided through a fully on MOS transistor. This pin is also monitored for under-voltage events.

SS (Pin 13)

Connect a small ceramic capacitor (0.1 μF recommended) from this pin to GND. The internal Soft-start (SS) current source along with the external capacitor creates a voltage ramp used to control the ramp-up of the output voltages. Pulling this pin low with an open-drain device shuts down all the output as well as forces the FAULT pin low. The C_{SS} capacitor is also used to provide a controlled S4/S5 to active transition delay time.

12V (Pin 14)

Connect this pin to the ATX (or equivalent) 12V output. This pin is used to monitor the status of the power supply as well as provide bias for the NMOS-compatible output drivers. 12V presence at the chip in the absence of bias voltage, or severe 12V brownout during active states (S0, S1) operation can lead to chip misbehavior. RT9641A/B refuses entering active state before 12V power ready.

DRV2 (Pin 15)

For the 2.5V RDRAM systems, connect this pin to the base of a suitable NPN transistor. This pass transistor regulates the 2.5V(2.6V) output from the ATX 3.3V during active states operation. For 3.3V SDRAM systems connect this pin to the gate of a suitable N-MOS transistor or the base of a suitable NPN transistor.

VSEN2 (Pin 16)

Connect this pin to the memory output (V_{OUT2}). In sleep states, this pin is regulated to 2.5V(2.6V) or 3.3V(3.43V) (based on R_{SEL}) through an internal pass transistor capable of delivering 300mA (Typically). The active-state voltage at this pin is regulated through an external NPN or NMOS transistor connected at the DRV2 pin for both 2.5V(2.6V) and 3.3V(3.43V) setting. During all operating states, the voltage at this pin is monitored for under-voltage events.

Applications Information

Operation

The RT9641A/B controls 3 output voltages. It is designed for microprocessor computer applications with 3.3V, 5V, 5VSB, and 12V outputs from an ATX power supply. The IC is composed of two linear controllers supplying the PCI slots' 3.3V_{AUX} power (3.3V_{DUAL}, V_{OUT1}) and the 2.5V RDRAM or 3.3V SDRAM memory power (2.5V/3.3V(2.6V/3.43V) V_{MEM} , V_{OUT2}), and a dual switch controller supplying the 5V_{DUAL} voltage (V_{OUT3}). In addition, all the control and monitoring functions necessary for complete ACPI implementation are integrated into the RT9641A/B.

Initialization

The RT9641A/B automatically initializes upon receipt of input power. The Power-On Reset (POR) function continually monitors the 5VSB input supply voltage, initiating soft-start operation after it exceeds its POR threshold (in S4/S5 states). The 5VSB POR trip event is also used to lock in the memory voltage setting based on R_{SEL} .

The RT9641A/B forces the operation mode to start from S4/S5 states at POR releasing.

Operational Truth Tables

The $\overline{EN3VDL}$ and EN5VDL pins offer a host of choices in terms of the overall system architecture and supported features. Tables 1~3 describe the truth combinations pertaining to each of the three outputs.

Table 1. 3.3V_{DUAL} Output (V_{OUT1}) Truth Table

| $\overline{EN3VDL}$ | $\overline{S5}$ | $\overline{S3}$ | 3V3DL | Comments |
|---------------------|-----------------|-----------------|-------|--------------------------|
| 0 | 1 | 1 | 3.3V | S0, S1 States (Active) |
| 0 | 1 | 0 | 3.3V | S3 |
| 0 | 0 | 1 | Note | Maintains Previous State |
| 0 | 0 | 0 | 3.3V | S4/S5 |
| 1 | 1 | 1 | 3.3V | S0, S1 States (Active) |
| 1 | 1 | 0 | 3.3V | S3 |
| 1 | 0 | 1 | Note | Maintains Previous State |
| 1 | 0 | 0 | 0V | S4/S5 |

Note: Combination not allowed.

As seen in Table 1, $\overline{EN3VDL}$ simply controls whether the 3.3V_{DUAL} plane remains powered up during S4/S5 sleep state.

Table 2. 5VDUAL Output (V_{OUT3}) Truth Table

| EN5VDL | $\overline{S5}$ | $\overline{S3}$ | 5VDL | Comments |
|--------|-----------------|-----------------|------|--------------------------|
| 0 | 1 | 1 | 5V | S0, S1 States(Active) |
| 0 | 1 | 0 | 0V | S3 |
| 0 | 0 | 1 | Note | Maintains Previous State |
| 0 | 0 | 0 | 0V | S4/S5 |
| 1 | 1 | 1 | 5V | S0, S1 States(Active) |
| 1 | 1 | 0 | 5V | S3 |
| 1 | 0 | 1 | Note | Maintains Previous State |
| 1 | 0 | 0 | 5V | S4/S5 |

Note: Combination not allowed.

Very similarly, Table 2 details the fact that EN5VDL status controls whether the 5VDUAL plane supports sleeps states.

Table 3. 2.5V/3.3V(2.6V/3.43V) VMEM Output (V_{OUT2}) Truth Table

| RSEL | $\overline{S5}$ | $\overline{S3}$ | 2.5V/3.3V | Comments |
|--------------|-----------------|-----------------|------------|--------------------------|
| 1k Ω | 1 | 1 | 2.5V/2.6V | S0, S1 States(Active) |
| 1k Ω | 1 | 0 | 2.5V | S3 |
| 1k Ω | 0 | 1 | Note | Maintains Previous State |
| 1K Ω | 0 | 0 | 0V | S4/S5 |
| 10k Ω | 1 | 1 | 3.3V/3.43V | S0, S1 States(Active) |
| 10k Ω | 1 | 0 | 3.3V | S3 |
| 10k Ω | 0 | 1 | Note | Maintains Previous State |
| 10k Ω | 0 | 0 | 0V | S4/S5 |

Note: Combination not allowed.

As seen in Table 3, 2.5V/3.3V(2.6V/3.43V) VMEM output is maintained in S3 (Suspend-To-RAM), but not in S4/S5 state. The dual-voltage support accommodates both SDRAM as well as RDRAM type memories.

Fault Protection

All the outputs are monitored against under-voltage events. A serve over-current caused by a failed load on any of the outputs, would, in turn, cause that specific output to suddenly drop. If any of the output voltages drop below 68% of their set value, such event is reported by having the FAULT/MSEL pin pulled to 5V. Additionally, the 2.5V/3.3V(2.6V/3.43V) memory regulator is internally current limited while in a sleep state. Exceeding the maximum current rating of this output in a sleep state can lead to output voltage drooping. If excessive, this droop can ultimately trip the under-voltage detector and send a FAULT signal to the computer system. However, a FAULT condition will only set off the FAULT flag, and it will not shut off or latch off any part of the circuit. If shutdown or latch off the circuit is desired, this can be achieved by externally pulling or latching the SS pin low. Pulling the SS pin low will also force the FAULT pin to go low.

Under-voltage sensing is disabled on all disabled outputs and during soft-start ramp-up intervals.

Another condition that could set off the FAULT flag is chip over-temperature. If the RT9641A/B reaches an internal temperature of 145°C (typical), the FAULT flag is set (FAULT/MSEL pulled high), but the chip continues to operate until the temperature reaches 155°C (typical), when unconditional shutdown of all outputs takes place. The thermal shutdown can be released with a re-soft-start when the chip cools down.

Shutdown

In case of a FAULT condition that might endanger the computer system, or at any other time, the RT9641A/B can be shut down by pulling the SS pin below the specified shutdown level (typically 0.8V) with an open drain or open collector device capable of sinking a minimum of 2mA. Pulling the SS pin low effectively shuts down all the pass elements. Upon release of the SS pin, the RT9641A/B undergoes a new soft-start cycle and resumes normal operation in accordance to the ATX supply and control pins status.

Layout Considerations

The typical application employing a RT9641A/B is a fairly straight-forward implementation. Similar to any other linear regulators, attention has to be paid to a few potentially sensitive small signal components, such as those connected to high-impedance nodes or those supplying critical by-pass currents.

The power components (pass transistors) and the controller IC should be placed first. The controller should be placed in a central position on the motherboard, closer to the memory load if possible. Ensure the VSEN2 connection is properly sized to carry 300mA without significant resistive losses. The pass transistors should be placed on pads capable of heatsinking, matching the device's power dissipation. Where applicable, multiple via corrections to a large internal plane can significantly lower localized device temperature rise.

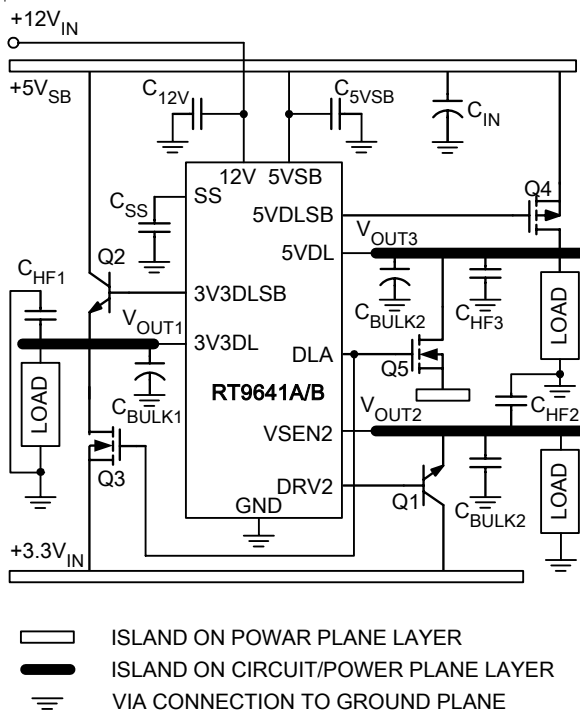

Figure 1 . Printed Circuit Board Islands

Placement of the decoupling and bulk capacitors should follow a placement reflecting their purpose. As such, the high-frequency decoupling capacitors (C_{HF}) should be placed as close as possible to the load they are decoupling; the ones decoupling the controller (C_{12V} , C_{5VSB}) close to the controller pins, the one decoupling the load close to the load connector or the load itself (if embedded). The bulk capacitance (aluminum electrolytic or tantalum capacitors) placement is not as critical as the high-frequency capacitor placement, but having these capacitors close to the load they serve is preferable.

The only critical small signal component is the soft-start capacitor, C_{SS} . Locate the component close to SS pin of the control IC and connect to ground through a vias placed close to the capacitor's ground pad. Minimize any leakage current paths from SS node, since the internal current source is only $5\mu A$.

A multi-layer printed circuit board is recommended. Figure 1 shows the connections of most of the components to the converter. Note that each individual capacitor could represent numerous physical capacitors. Dedicate one solid layer for a ground plane and make all critical component ground connections through vias placed as

close to the component as possible. Dedicate another solid layer as a power plane and break this plane into smaller islands of common voltage levels. Ideally, the power plane should support both the input power and output power nodes. Use copper filled polygons on the top and bottom circuit layers to create power islands connecting the filtering components (output capacitors) and the loads. Use the remaining printed circuit layers for small signal wiring.

Component Selection Guidelines

Output Capacitors Selection

The output capacitors for all outputs should be selected to allow the output voltage to meet the dynamic regulation requirements of active state operation (S0, S1). The load transient for the various microprocessor system's components may require high quality capacitors to supply the high slew rate (di/dt) current demands. Thus, it is recommended that capacitors C_{OUT1} and C_{OUT2} should be selected for transient load regulation.

Also, during the transition between active and sleep states, there is a short interval of time during which none of the power pass elements are conducting-during this time the output capacitors have to supply all the output current. The output voltage drop during this brief period of time can be approximated with the following formula:

$$\Delta V_{OUT} = I_{OUT} \times (ESR_{OUT} + t_t / C_{OUT}), \text{ where}$$

ΔV_{OUT} : output voltage drop

ESR_{OUT} : output capacitor bank ESR

I_{OUT} : output current during transition

C_{OUT} : output capacitor bank capacitance

t_t : active-to-sleep or sleep-to-active transition time ($5\mu S$ typical)

Since the output voltage drop is heavily dependent on the ESR (equivalent series resistance) of the output capacitor bank, the capacitors should be chosen to maintain the output voltage above the lowest allowable regulation level.

Input Capacitors Selection

The input capacitors for an RT9641A/B application must have sufficiently low ESR so that the input voltage does not dip excessively when energy is transferred to the output

Transistor Selection/Considerations

capacitors.

The RT9641A/B typically requires one P-channel or PNP transistor and two N-channel power MOSFETs and two bipolar NPN transistors.

One general requirement for selection of transistors for all the linear regulators/switching elements is package selection for efficient removal of heat. The power dissipated in a linear regulator/switching element is:

$$P_{\text{LINEAR}} = I_O \times (V_{\text{IN}} - V_{\text{OUT}})$$

Select a package and heatsink that maintains the junction temperature below the rating with the maximum expected ambient temperature.

Q1

The active element on the 2.5V/3.3V (2.6V/3.43V) V_{MEM} output has different requirements for each the two voltage settings. In 2.5V systems utilizing RDRAM (or voltage-compatible) memory, Q1 had better to be a bipolar NPN capable of conducting the maximum required output current and it must have a minimum current gain (h_{fe}) of 100~150 at this current and 0.7V V_{CE} . In such systems, the 2.5V(2.6V) output is regulated from the ATX 3.3V output while in an active state. In 3.3V systems (SDRAM or compatible) Q1 is suggested to use an N-channel MOSFET, then the MOSFET serves like a switch when it is connected to ATX3.3V during active states (S0, S1). The main criteria for the selection of this transistor is output voltage budgeting. The maximum $R_{\text{DS(ON)}}$ allowed at highest junction temperature can be expressed with the following equation:

$$R_{\text{DS(ON) MAX}} = (V_{\text{IN MIN}} - V_{\text{OUT MIN}}) / I_{\text{OUT MAX}}, \text{ where}$$

$V_{\text{IN MIN}}$: minimum input voltage

$V_{\text{OUT MIN}}$: minimum output voltage allowed.

$I_{\text{OUT MAX}}$: maximum output current

The gate bias available for this MOEFET is approximately 6V, so the logic level MOSFET is preferred. The 3.3V(3.43V) V_{MEM} power also can be regulated from ATX 5V in order to have high quality V_{MEM} , in such a configuration, either MOSFET or NPN transistors can be

used. While the heat dissipation should be carefully handled.

Q4

If a P-channel MOSFET is used to switch the 5VSB output of the ATX supply into the 5V_{DUAL} output during S3 and S4/S5 states (as dictated by EN5VDL status), then, similar to the situation where Q1 is a MOSFET, the selection criteria of this device is also proper voltage budgeting. The maximum $r_{\text{DS(ON)}}$, however, has to be achieved with only 4.5V of V_{GS} , so a logic level MOSFET needs to be selected. If a PNP device is chosen to perform this function, it has to have a low saturation voltage while providing the maximum sleep-state current and have current gain sufficiently high to be saturated using the minimum drive current (typically 20mA). A 100Ω ~ 200Ω resistor is recommended to be inserted between the 5VDLSB pin and Base node of the PNP transistor for limiting the base current.

Q3, Q5

The two N-channel MOSFETs are used to switch the 3.3V and 5V inputs provided by the ATX supply into the 3.3V_{DUAL} and 5V_{DUAL} outputs, respectively, while in active (S0, S1) state. Similar $R_{\text{DS(ON)}}$ criteria apply in these cases as well, unlike the PMOS, however, these NMOS transistors get the benefit of an increased V_{GS} drive (approximately 8V and 7V respectively).

Q2

The NPN transistor used as sleep-state pass element on the 3.3V_{DUAL} output must have a minimum current gain of 100 at $V_{\text{CE}} = 1.5\text{V}$ and $I_{\text{CE}} = 500\text{mA}$ throughout the in-circuit operating temperature range.

Outline Dimension

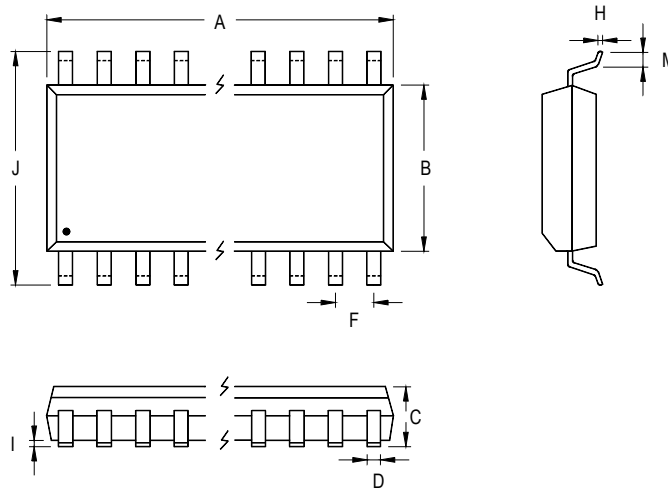

| Symbol | Dimensions In Millimeters | | Dimensions In Inches | |
|--------|---------------------------|--------|----------------------|-------|
| | Min | Max | Min | Max |
| A | 9.804 | 10.008 | 0.386 | 0.394 |
| B | 3.810 | 3.988 | 0.150 | 0.157 |
| C | 1.346 | 1.753 | 0.053 | 0.069 |
| D | 0.330 | 0.508 | 0.013 | 0.020 |
| F | 1.194 | 1.346 | 0.047 | 0.053 |
| H | 0.178 | 0.254 | 0.007 | 0.010 |
| I | 0.102 | 0.254 | 0.004 | 0.010 |
| J | 5.791 | 6.198 | 0.228 | 0.244 |
| M | 0.406 | 1.270 | 0.016 | 0.050 |

16-Lead SOP Plastic Package

RICHTEK TECHNOLOGY CORP.

Headquarter
 5F, No. 20, Taiyuen Street, Chupei City
 Hsinchu, Taiwan, R.O.C.
 Tel: (8863)5526789 Fax: (8863)5526611

RICHTEK TECHNOLOGY CORP.

Taipei Office (Marketing)
 8F-1, No. 137, Lane 235, Paochiao Road, Hsintien City
 Taipei County, Taiwan, R.O.C.
 Tel: (8862)89191466 Fax: (8862)89191465
 Email: marketing@richtek.com