

NJG1715KC1

■ ABSOLUTE MAXIMUM RATINGS

($T_a=+25^{\circ}\text{C}$, $Z_s=Z_l=50\Omega$)

PARAMETER	SYMBOL	CONDITIONS	RATINGS	UNITS
LNA Voltage	V_{LNA}		5.0	V
Mixer Voltage	V_{MIX}		5.0	V
Local Amplifier Voltage	V_{LO}		5.0	V
Input Power 1	P_{LNAIN}	$V_{LNA}=V_{MIX}=V_{LO}=2.85\text{V}$	+15	dBm
Input Power 2	P_{LOIN}	$V_{LNA}=V_{MIX}=V_{LO}=2.85\text{V}$	+10	dBm
Power Dissipation	P_D		550	mW
Operating Temperature	T_{opr}		-40~+85	$^{\circ}\text{C}$
Storage Temperature	T_{stg}		-55~+125	$^{\circ}\text{C}$

■ ELECTRICAL CHARACTERISTICS 1 (LNA)

GENERAL CONDITIONS: $T_a=+25^{\circ}\text{C}$, $V_{LNA}=2.85\text{V}$, $V_{MIX}=V_{LO}=0\text{V}$, $f_{RF}=2140\text{MHz}$, $P_{RF}=-36\text{dBm}$,
 $Z_s=Z_l=50\Omega$, with test circuit

PARAMETER	SYMBOL	CONDITIONS	MIN	TYP	MAX	UNITS
Operating Frequency	freq		2110	2140	2170	MHz
LNA Voltage	V_{LNA}		2.5	2.85	4.5	V
LNA Operating Current	I_{LNA}	$P_{RF}, P_{LO}=\text{OFF}$	-	2.8	3.5	mA
Small Signal Gain	Gain		13.0	15.0	17.0	dB
Gain Flatness	G_{flat}	$f_{RF}=2110\sim 2170\text{MHz}$	-	0.5	1.0	dB
Noise Figure	NF		-	1.3	1.5	dB
Pout at 1dB Gain Compression point	P_{-1dB}		-2.0	+1.0	-	dBm
Input 3rd order Intercept point	IIP3	$f_{RF}=2140.0+2140.1\text{MHz}$	-7.0	-2.0	-	dBm
RF IN VSWR	$VSWR_i$		-	2.0	-	
RF OUT VSWR	$VSWR_o$		-	2.0	-	

■ ELECTRICAL CHARACTERISTICS 2 (Mixer)

GENERAL CONDITIONS: $T_a=+25^{\circ}\text{C}$, $V_{LNA}=0\text{V}$, $V_{MIX}=V_{LO}=2.85\text{V}$, $f_{RF}=2140\text{MHz}$, $f_{LO}=2520\text{MHz}$,
 $P_{RF}=-30\text{dBm}$, $P_{LO}=-10\text{dBm}$, $Z_s=Z_l=50\Omega$, with test circuit

PARAMETER	SYMBOL	CONDITIONS	MIN	TYP	MAX	UNITS
Operating Frequency	freq		2110	2140	2170	MHz
Mixer Voltage	V_{MIX}		2.5	2.85	4.5	V
Local Amplifier Voltage	V_{LO}		2.5	2.85	4.5	V
Mixer Operating Current	I_{MIX}	$P_{RF}, P_{LO}=\text{OFF}$	-	4.6	6.0	mA
Local Amplifier Operating Current	I_{LO}	$P_{RF}, P_{LO}=\text{OFF}$	-	0.9	1.3	mA
Conversion Gain	G_c		10.0	11.5	-	dB
Noise Figure	NF		-	5.0	7.0	dB
Input 3rd Order Intercept Point	IIP3	$f_{RF}=2140.0+2140.1\text{MHz}$	-3.0	+1.0	-	dBm
MIXER IN VSWR	$VSWR_M$		-	1.5	-	
LOCAL IN VSWR	$VSWR_L$		-	1.5	-	
IF OUT VSWR	$VSWR_i$		-	1.5	-	

■ TERMINAL INFORMATION

No.	SYMBOL	FUNCTION
1	LNAIN	RF input terminal of LNA. An external matching circuit is required.
2	LNACAP	Terminal for the bypass capacitor of LNA. The bypass capacitor C1 shown in test circuits should be connected to this terminal as close as possible.
3	GND	Ground terminal (0V)
4	IFOUT	IF signal output terminal. The IF signal is output through external matching circuit connected to this terminal. Please connect inductances L7, L8 and power supply as shown in test circuits, since this terminal is also the terminal of mixer power supply.
5	VLO	Power supply terminal for local amplifier. Please place R1 and L11 shown in test circuits at very close to this terminal.
6	LOIN	Local signal input terminal to local amplifier. An external matching circuit is required.
7	BPC	Terminal for the bypass capacitor of mixer. The bypass capacitor C4 shown in test circuits should be connected to this terminal as close as possible.
8	MIXIN	RF signal input terminal to mixer. An external matching circuit is required.
9	GND	Ground terminal (0V)
10	LNAOUT	Signal output terminal of LNA. The RF signal from LNA goes out through external matching circuit connected to this terminal. Please connect inductances L3, L4 and power supply as shown in test circuits, since this terminal is also the terminal of LNA power supply.

CAUTION

- 1) Ground terminal (No.3, 9) should be connected to the ground plane as close as possible.

NJG1715KC1

■ TYPICAL CHARACTERISTICS (LNA, with test circuit)

Gain, Noise Figure vs. Frequency

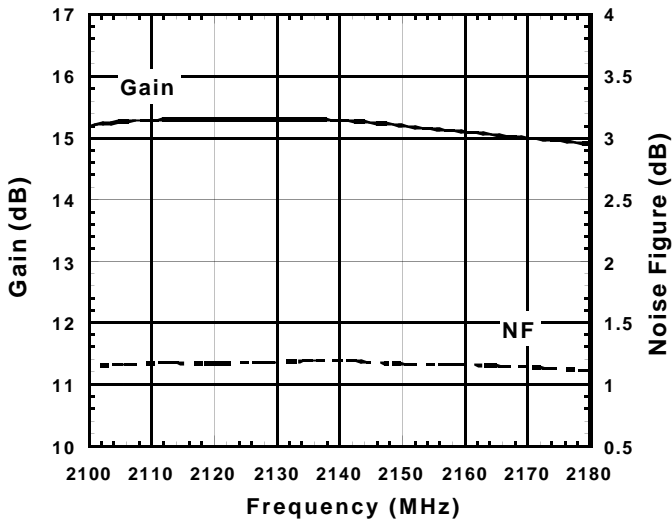

Condition
 $f=2110\sim 2170\text{MHz}$
 $V_{LNA}=2.85\text{V}$
 $V_{MIX}=V_{LO}=0\text{V}$

Output Power vs. Input Power

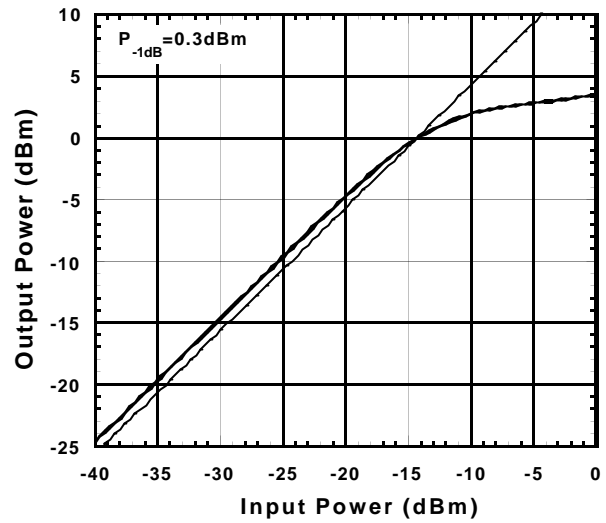

Condition
 $f=2140\text{MHz}$
 $V_{LNA}=2.85\text{V}$
 $V_{MIX}=V_{LO}=0\text{V}$

Output Power, IM3 vs. Input Power

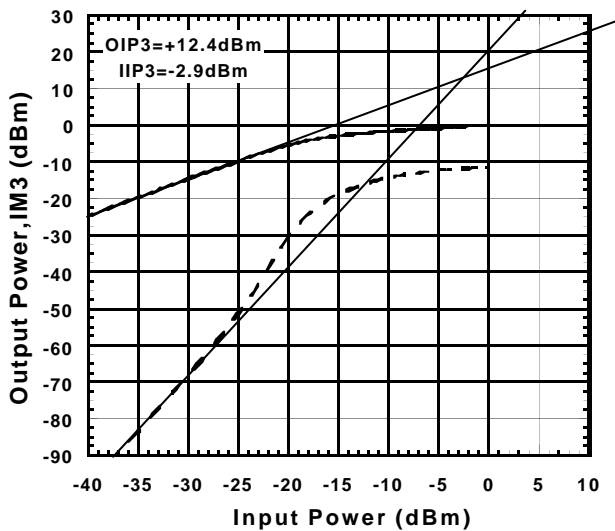

Condition
 $f=2140+2140.1\text{MHz}$
 $V_{LNA}=2.85\text{V}$
 $V_{MIX}=V_{LO}=0\text{V}$

Output Power, IM3 vs. Input Power

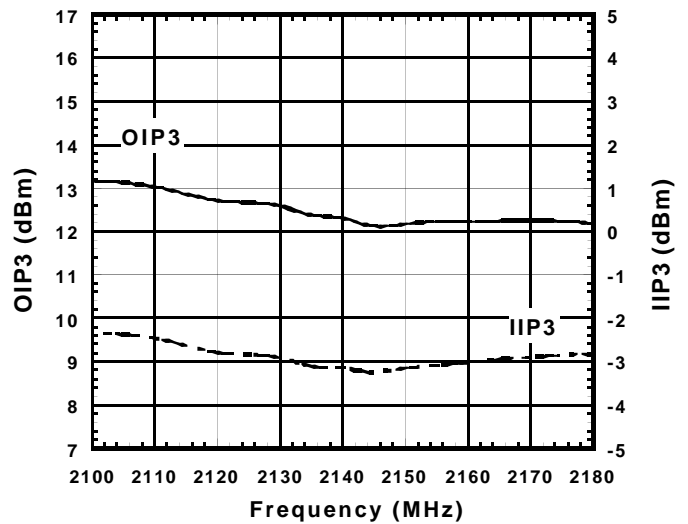

Condition
 $f=2110\sim 2170\text{MHz}$
 $f_{\text{OFFSET}}=100\text{kHz}$
 $P_{\text{in}}=-30\text{dBm}$
 $V_{LNA}=2.85\text{V}$
 $V_{MIX}=V_{LO}=0\text{V}$

■ TYPICAL CHARACTERISTICS (LNA, with test circuit)

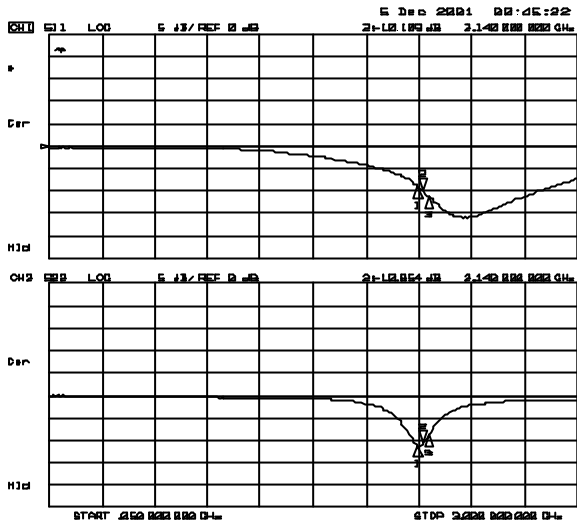

S11 & S22
 Condition
 $V_{LNA}=2.85V$
 $V_{MIX}=V_{LO}=0V$

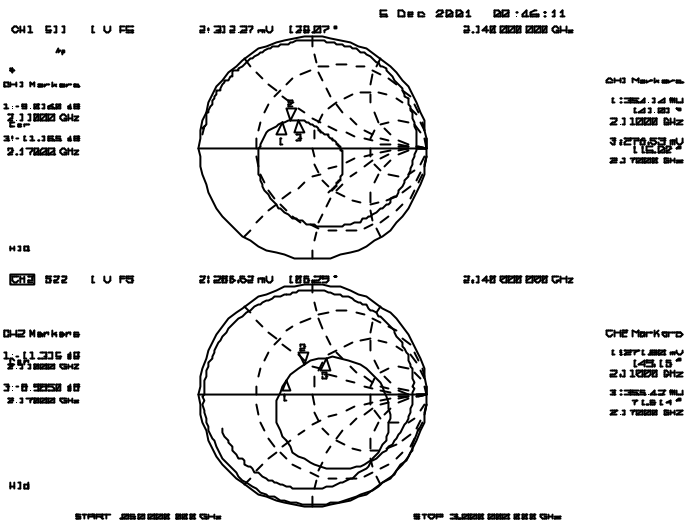

Z11 & Z22
 Condition
 $V_{LNA}=2.85V$
 $V_{MIX}=V_{LO}=0V$

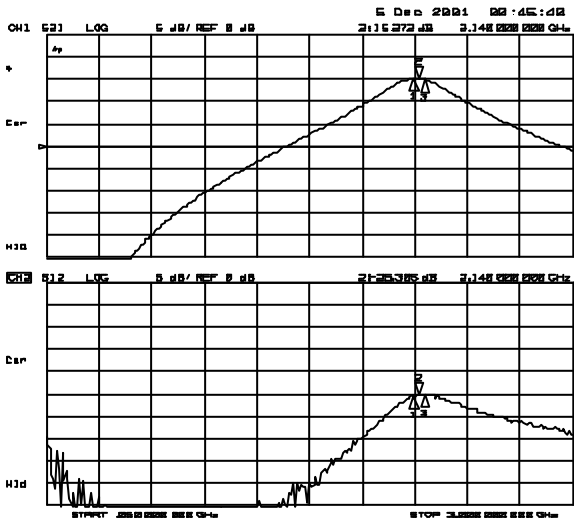

S21 & S12
 Condition
 $V_{LNA}=2.85V$
 $V_{MIX}=V_{LO}=0V$

NJG1715KC1

■ TYPICAL CHARACTERISTICS (LNA, with test circuit)

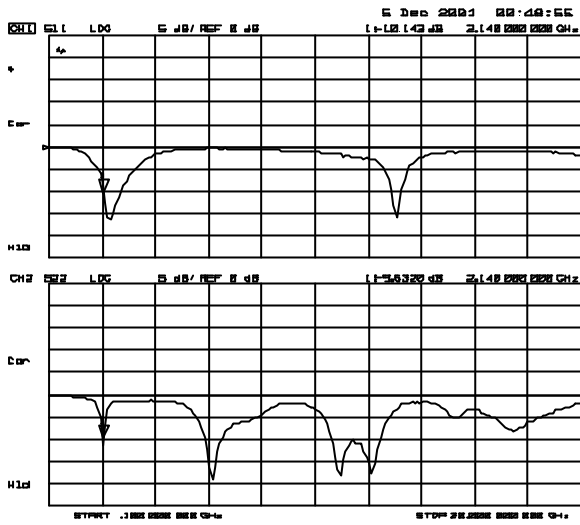

S11 & S22(~20GHz)
 Condition
 $V_{LNA}=2.85V$
 $V_{MIX}=V_{LO}=0V$

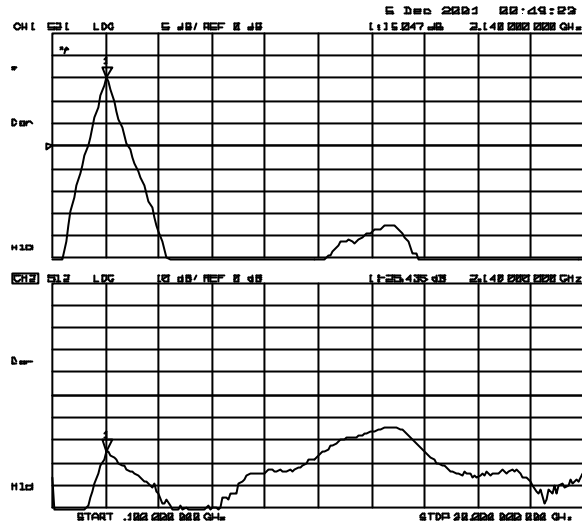

S21 & S12(~20GHz)
 Condition
 $V_{LNA}=2.85V$
 $V_{MIX}=V_{LO}=0V$

■ TYPICAL CHARACTERISTICS (LNA, with test circuit)

Gain, Noise Figure vs. Temperature

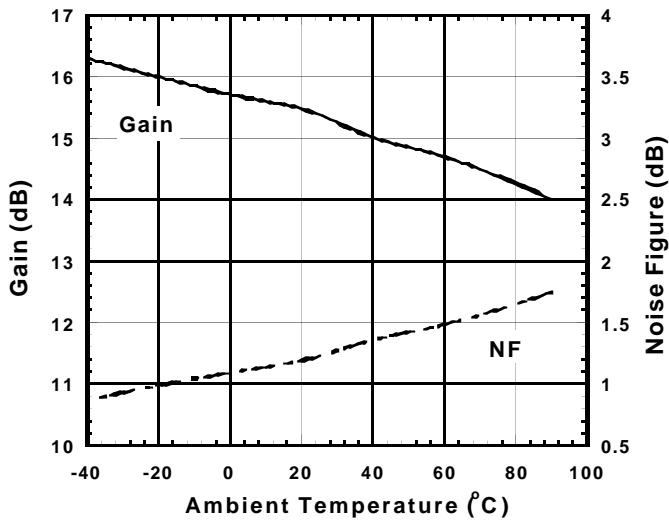

Condition
 $f=2140\text{MHz}$
 $V_{LNA}=2.85\text{V}$
 $V_{MIX}=V_{LO}=0\text{V}$

OIP3, IIP3 vs. Temperature

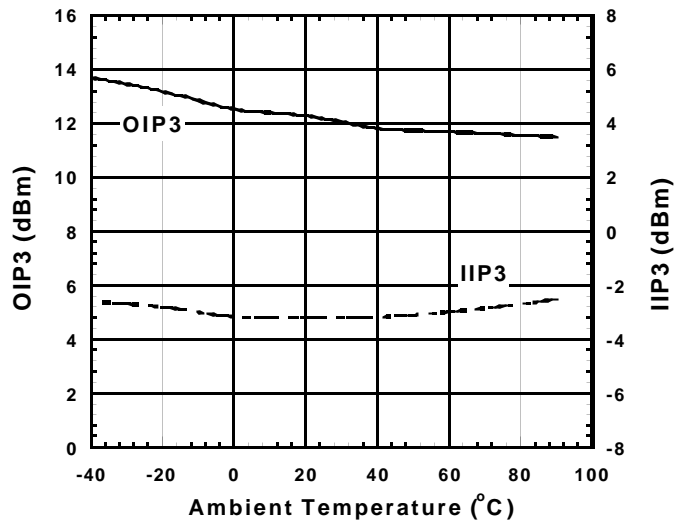

Condition
 $f=2140+2140.1\text{MHz}$
 $\text{Pin}=-30\text{dBm}$
 $V_{LNA}=2.85$
 $V_{MIX}=V_{LO}=0\text{V}$

P-1dB, I_{LNA} vs. Temperature

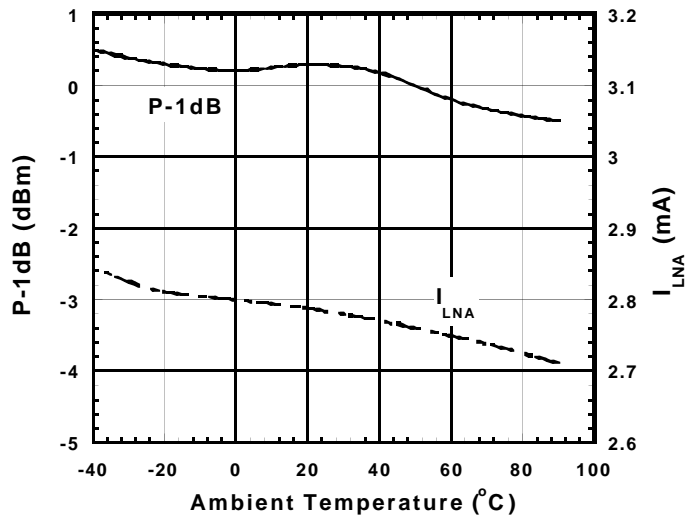

Condition
 $f=2140\text{MHz}$
 $V_{LNA}=2.85\text{V}$
 $V_{MIX}=V_{LO}=0\text{V}$

NJG1715KC1

■ TYPICAL CHARACTERISTICS (MIXER, with test circuit)

Conversion Gain, Noise Figure vs. RF Frequency

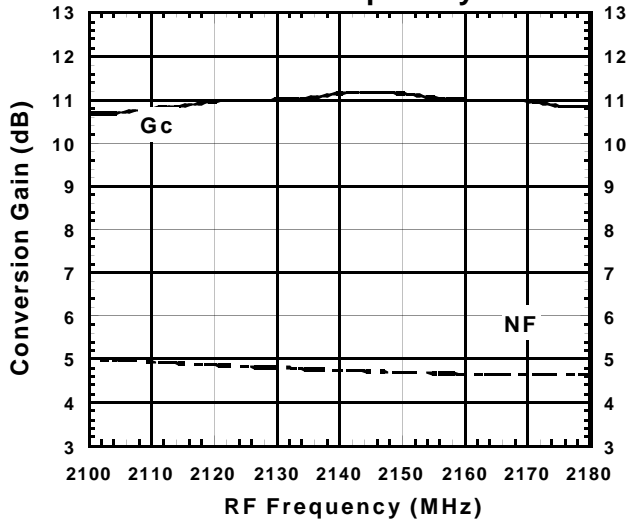

Condition
 $f_{IF}=380\text{MHz}$
 $f_{RF}=2110\sim 2170\text{MHz}, P_{RF}=-30\text{dBm}$
 Upper LOCAL, $P_{LO}=-10\text{dBm}$
 $V_{LNA}=0\text{V}$
 $V_{MIX}=V_{LO}=2.85\text{V}$

Conversion Gain, Noise Figure vs. LO Power

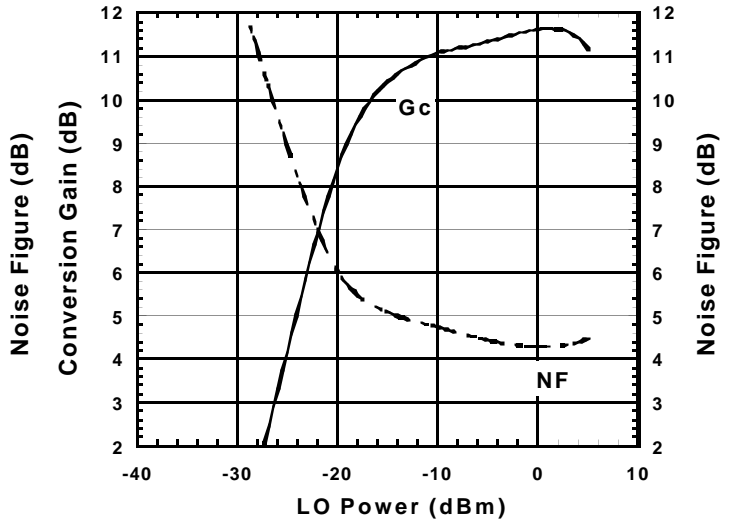

Condition
 $f_{IF}=380\text{MHz}$
 $f_{RF}=2140\text{MHz}, P_{RF}=-30\text{dBm}$
 $f_{LO}=2520\text{MHz}$
 $V_{LNA}=0\text{V}$
 $V_{MIX}=V_{LO}=2.85\text{V}$

OIP3, IIP3 vs. RF Frequency

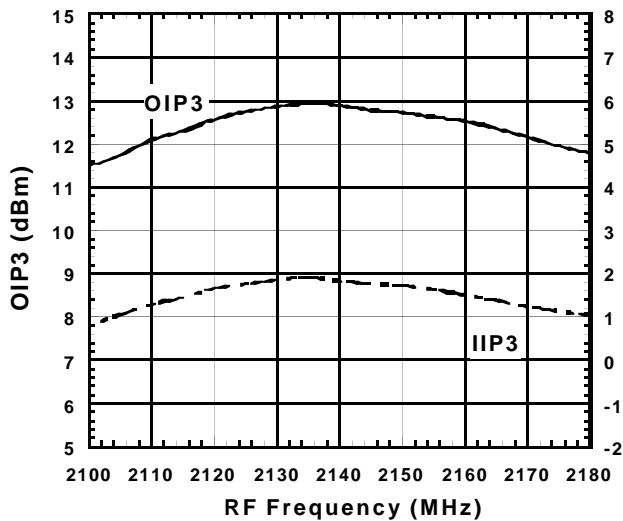

Condition
 $f_{IF}=380\text{MHz}$
 $f_{RF}=2110\sim 2170\text{MHz}, P_{RF}=-30\text{dBm}$
 $f_{RF\ OFFSET}=100\text{kHz}$
 Upper LOCAL, $P_{LO}=-10\text{dBm}$
 $V_{LNA}=0\text{V}$
 $V_{MIX}=V_{LO}=2.85\text{V}$

$$OIP3 = (3 \times IIP3 - IM3) / 2$$

$$IIP3 = OIP3 - Gc$$

OIP3, IIP3 vs. LO Power

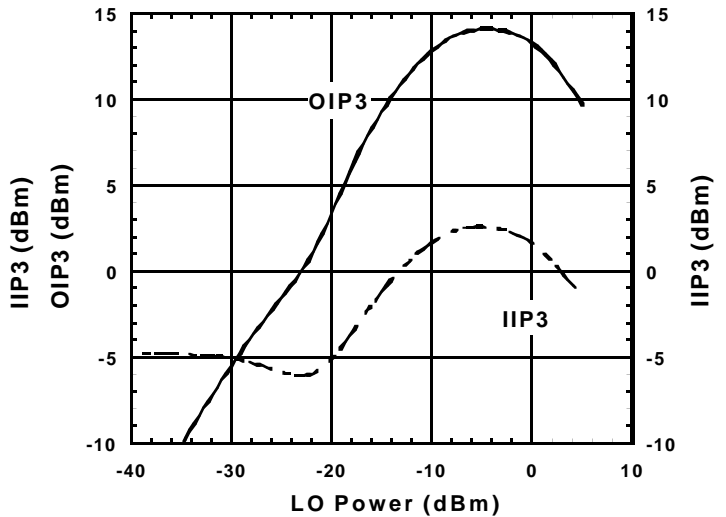

Condition
 $f_{IF}=380\text{MHz}$
 $f_{RF}=2140+2140.1\text{MHz}, P_{RF}=-30\text{dBm}$
 $f_{LO}=2520\text{MHz}$
 $V_{LNA}=0\text{V}$
 $V_{MIX}=V_{LO}=2.85\text{V}$

■ TYPICAL CHARACTERISTICS (MIXER, with test circuit)

IF Output Power vs. RF Power

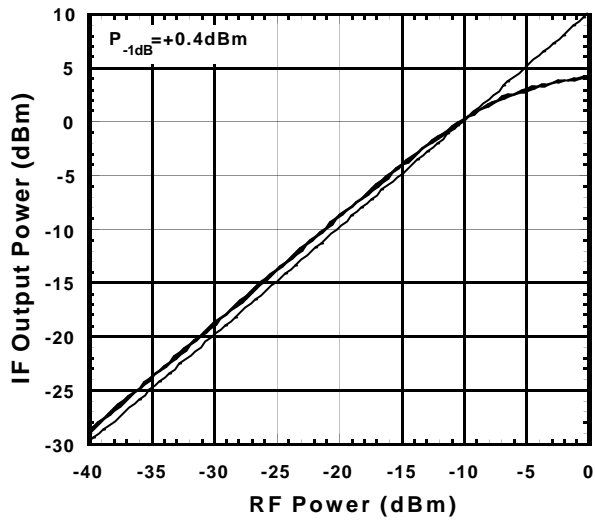

Condition
 $f_{IF} = 380 \text{ MHz}$
 $f_{RF} = 2140 \text{ MHz}$
 $f_{LO} = 2520 \text{ MHz}, P_{LO} = -10 \text{ dBm}$
 $V_{LNA} = 0 \text{ V}$
 $V_{MIX} = V_{LO} = 2.85 \text{ V}$

IF, IM3 vs. RF Power

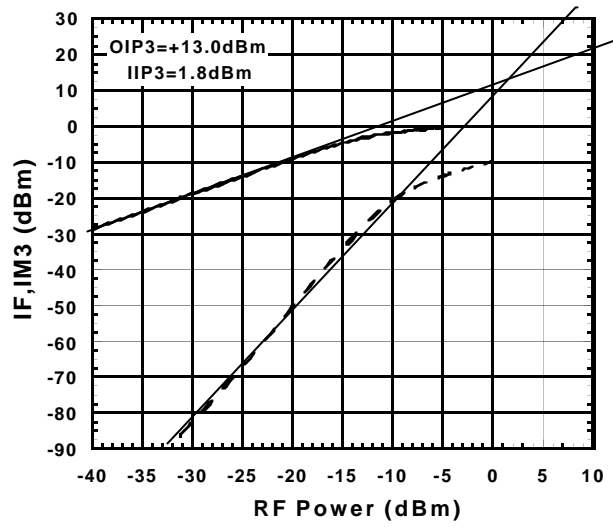

Condition
 $f_{IF} = 380 \text{ MHz}$
 $f_{RF} = 2140 + 2140.1 \text{ MHz}$
 $f_{LO} = 2520 \text{ MHz}, P_{LO} = -10 \text{ dBm}$
 $V_{LNA} = 0 \text{ V}$
 $V_{MIX} = V_{LO} = 2.85 \text{ V}$

NJG1715KC1

■ TYPICAL CHARACTERISTICS (MIXER, with test circuit)

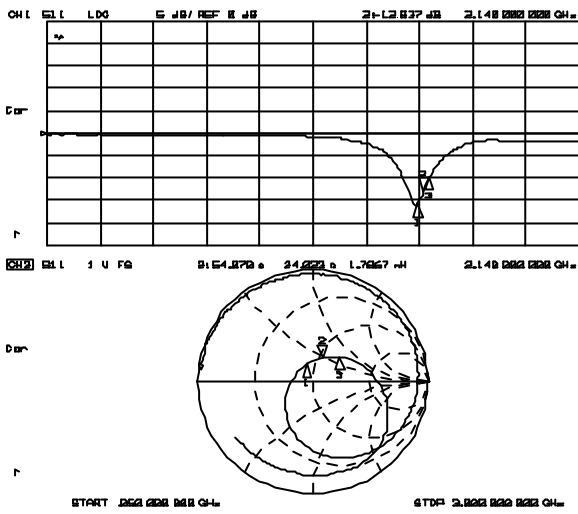

MIXER IN Impedance
Condition
LOCAL IN, IF OUT 50Ωterm.
Source Power=-30dBm
 $V_{LNA} = 0V, V_{MIX} = V_{LO} = 2.85V$

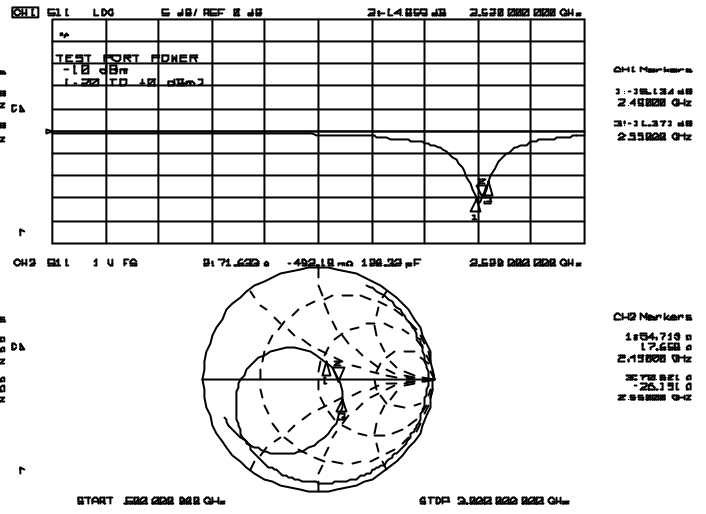

LOCAL IN Impedance
Condition
MIXER IN, IF OUT 50Ωterm.
Source Power=-10dBm
 $V_{LNA} = 0V, V_{MIX} = V_{LO} = 2.85V$

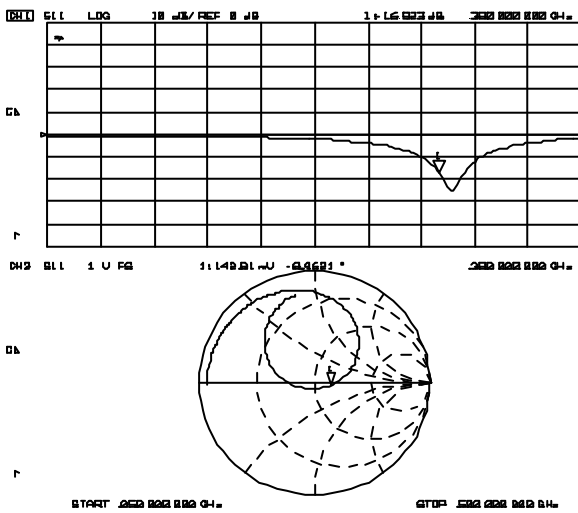

IF OUT Impedance
Condition
MIXER IN, LOCAL IN 50Ωterm.
Source Power=-10dBm
 $V_{LNA} = 0V, V_{MIX} = V_{LO} = 2.85V$

■ **TYPICAL CHARACTERISTICS (MIXER, with test circuit)**

**Conversion Gain vs. RF Frequency
Temperature Response**

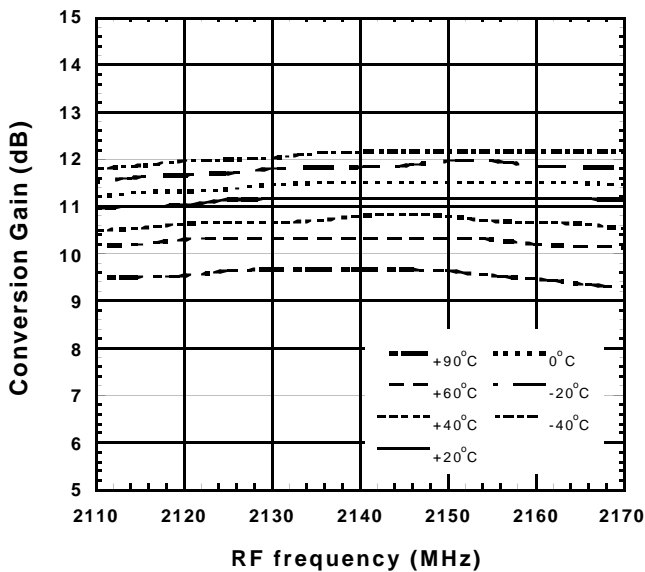

Condition
 $f_{IF}=380\text{MHz}$
 $f_{RF}=2110\sim 2170\text{MHz}, P_{RF}=-30\text{dBm}$
 Upper LOCAL, $P_{LO}=-10\text{dBm}$
 $V_{LNA}=0\text{V}$
 $V_{MIX}=V_{LO}=2.85\text{V}$

**Noise Figure vs. RF Frequency
Temperature Response**

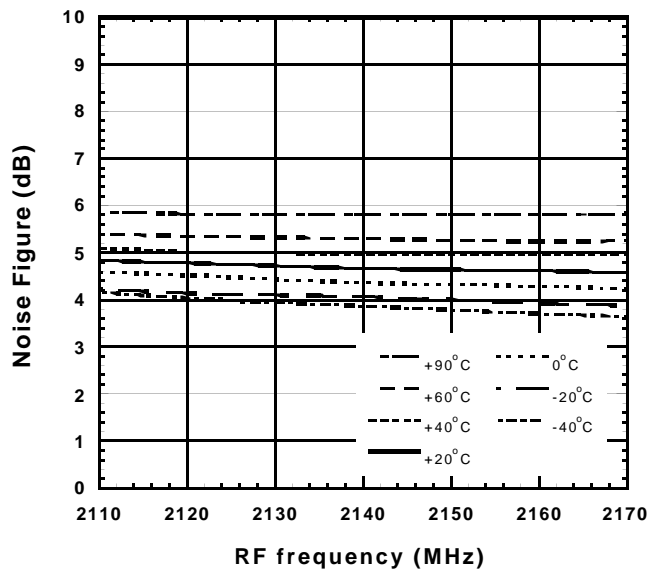

Condition
 $f_{IF}=380\text{MHz}$
 $f_{RF}=2110\sim 2170\text{MHz}, P_{RF}=-30\text{dBm}$
 Upper LOCAL, $P_{LO}=-10\text{dBm}$
 $V_{LNA}=0\text{V}$
 $V_{MIX}=V_{LO}=2.85\text{V}$

**IIP3 vs. RF Frequency
Temperature Response**

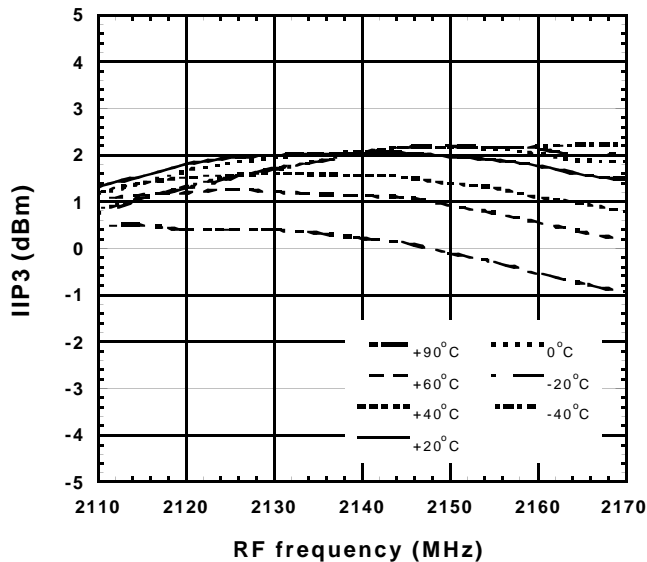

Condition
 $f_{IF}=380\text{MHz}$
 $f_{RF}=2110\sim 2170\text{MHz}, P_{RF}=-30\text{dBm}$
 $f_{RF\ OFFSET}=100\text{kHz}$
 Upper LOCAL, $P_{LO}=-30\text{dBm}$
 $V_{LNA}=0\text{V}$
 $V_{MIX}=V_{LO}=2.85\text{V}$

NJG1715KC1

■ TYPICAL CHARACTERISTICS (MIXER, with test circuit)

Conversion Gain vs. LO Power
Temperature Response

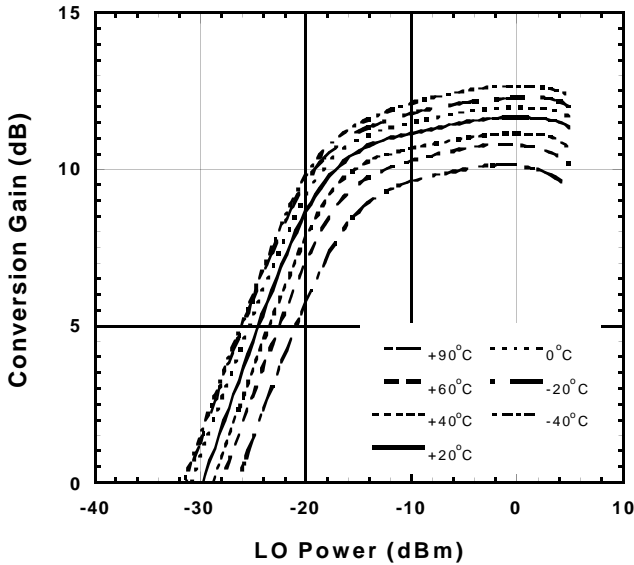

Condition
 $f_{IF}=380\text{MHz}$
 $f_{RF}=2140\text{MHz}, P_{RF}=-30\text{dBm}$
 $f_{LO}=2520\text{MHz}$
 $V_{LNA}=0\text{V}$
 $V_{MIX}=V_{LO}=2.85\text{V}$

Noise Figure vs. LO Power
Temperature Response

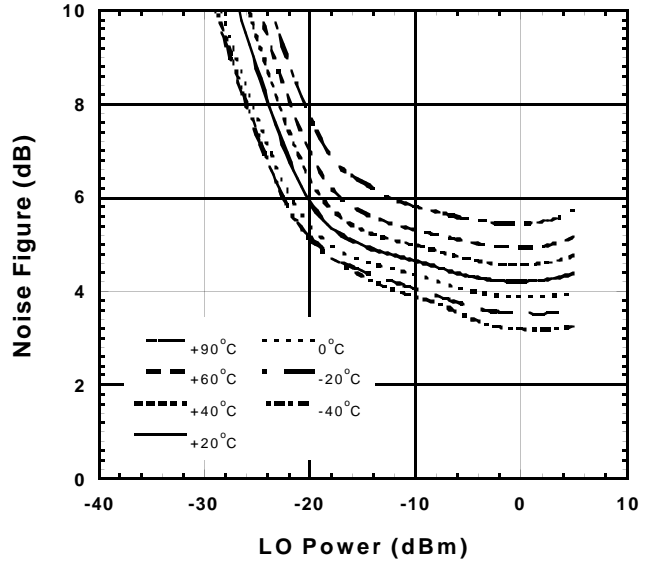

Condition
 $f_{IF}=380\text{MHz}$
 $f_{RF}=2140\text{MHz}, P_{RF}=-30\text{dBm}$
 $f_{LO}=2520\text{MHz}$
 $V_{LNA}=0\text{V}$
 $V_{MIX}=V_{LO}=2.85\text{V}$

IIP3 vs. LO Power
Temperature Response

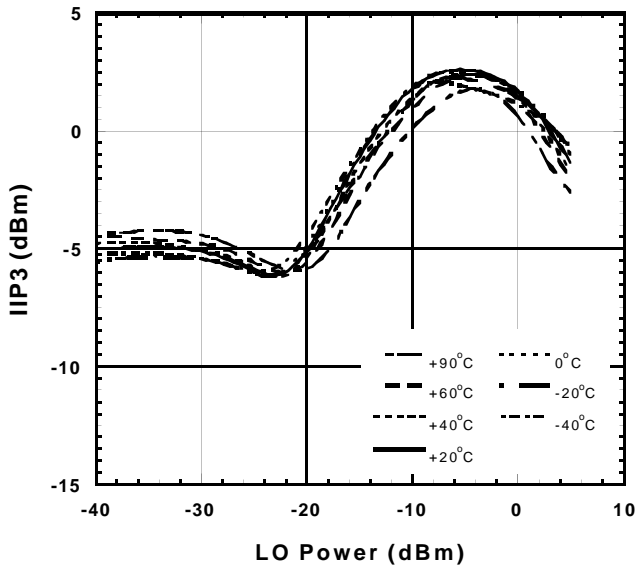

Condition
 $f_{IF}=380\text{MHz}$
 $f_{RF}=2140+2140.1\text{MHz}, P_{RF}=-30\text{dBm}$
 $f_{LO}=2520\text{MHz}$
 $V_{LNA}=0\text{V}$
 $V_{MIX}=V_{LO}=2.85\text{V}$

I_{MIX}, I_{LO} vs. Temperature

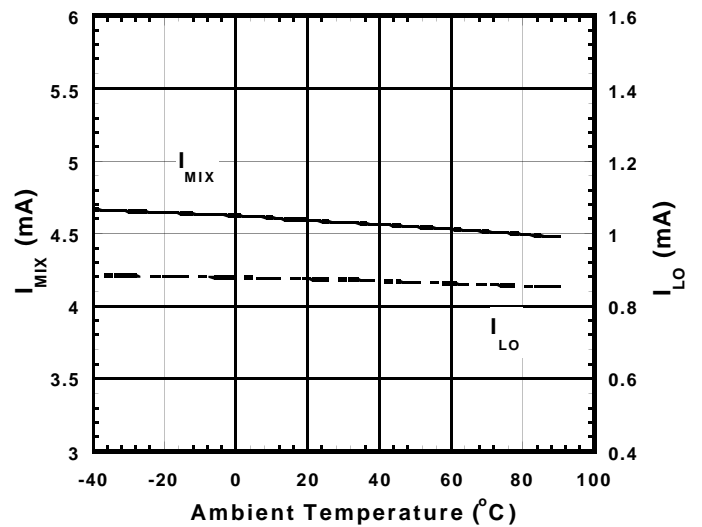

Condition
 $V_{LNA}=0\text{V}$
 $V_{MIX}=V_{LO}=2.85\text{V}$

TEST CIRCUIT

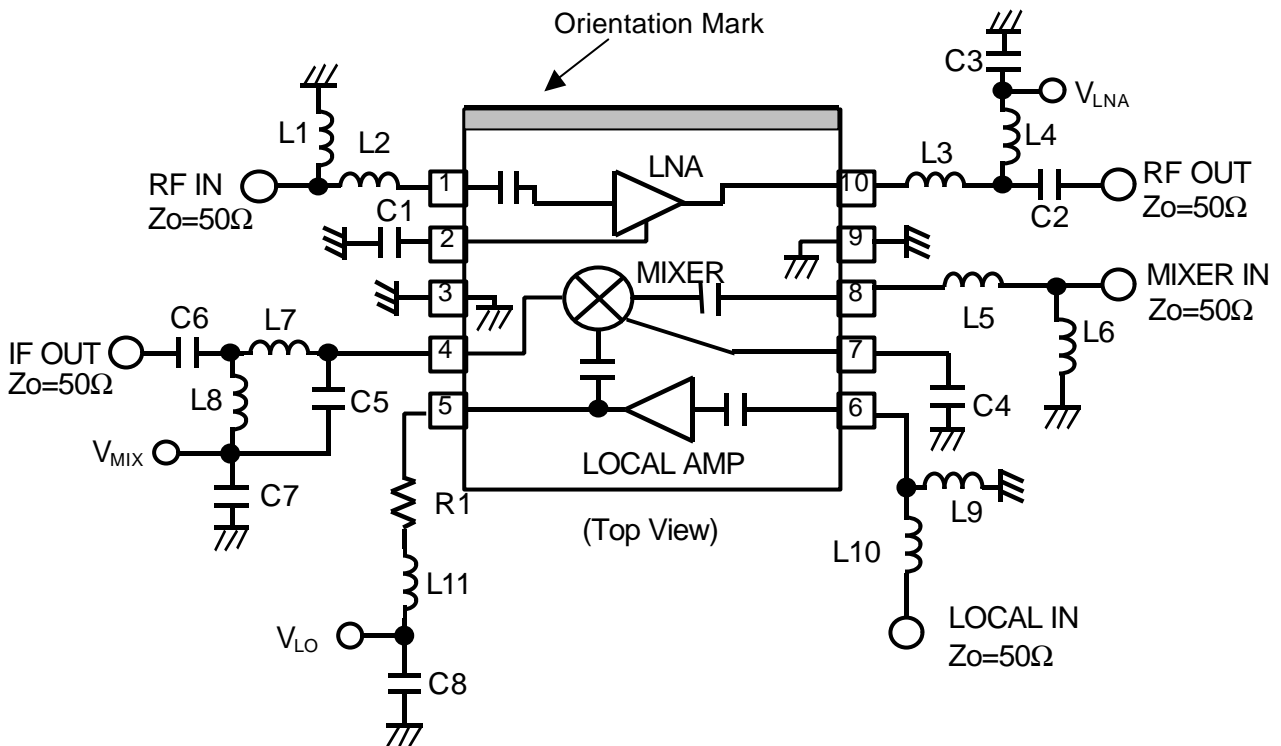

PARTS LIST

PART ID	2.1GHz BAND		COMMENT
	Upper Local		
	f _{RF} =2140MHz, f _{LO} =2520MHz, f _{IF} =380MHz		
L1	5.6nH	TAIYO-YUDEN (HK1005)	
L2	4.7nH	TAIYO-YUDEN (HK1005)	
L3	5.6nH	TAIYO-YUDEN (HK1005)	
L4	1.5nH	TAIYO-YUDEN (HK1005)	
L5	2.7nH	TAIYO-YUDEN (HK1005)	
L6	1.5nH	TAIYO-YUDEN (HK1005)	
L7	39nH	TAIYO-YUDEN (HK1608)	
L8	18nH	TAIYO-YUDEN (HK1005)	
L9	6.8nH	TAIYO-YUDEN (HK1005)	
L10	8.2nH	TAIYO-YUDEN (HK1005)	
L11	2.7nH	TAIYO-YUDEN (HK1005)	
C1	10pF	MURATA (GRM36)	
C2	7pF	MURATA (GRM36)	
C3	1000pF	MURATA (GRM36)	
C4	470pF	MURATA (GRM36)	
C5	2pF	MURATA (GRM36)	
C6	470pF	MURATA (GRM36)	
C7	0.01uF	MURATA (GRM36)	
C8	0.01uF	MURATA (GRM36)	
R1	5.1Ω	CHIP SIZE 1005	

NJG1715KC1

RECOMMENDED PCB DESIGN

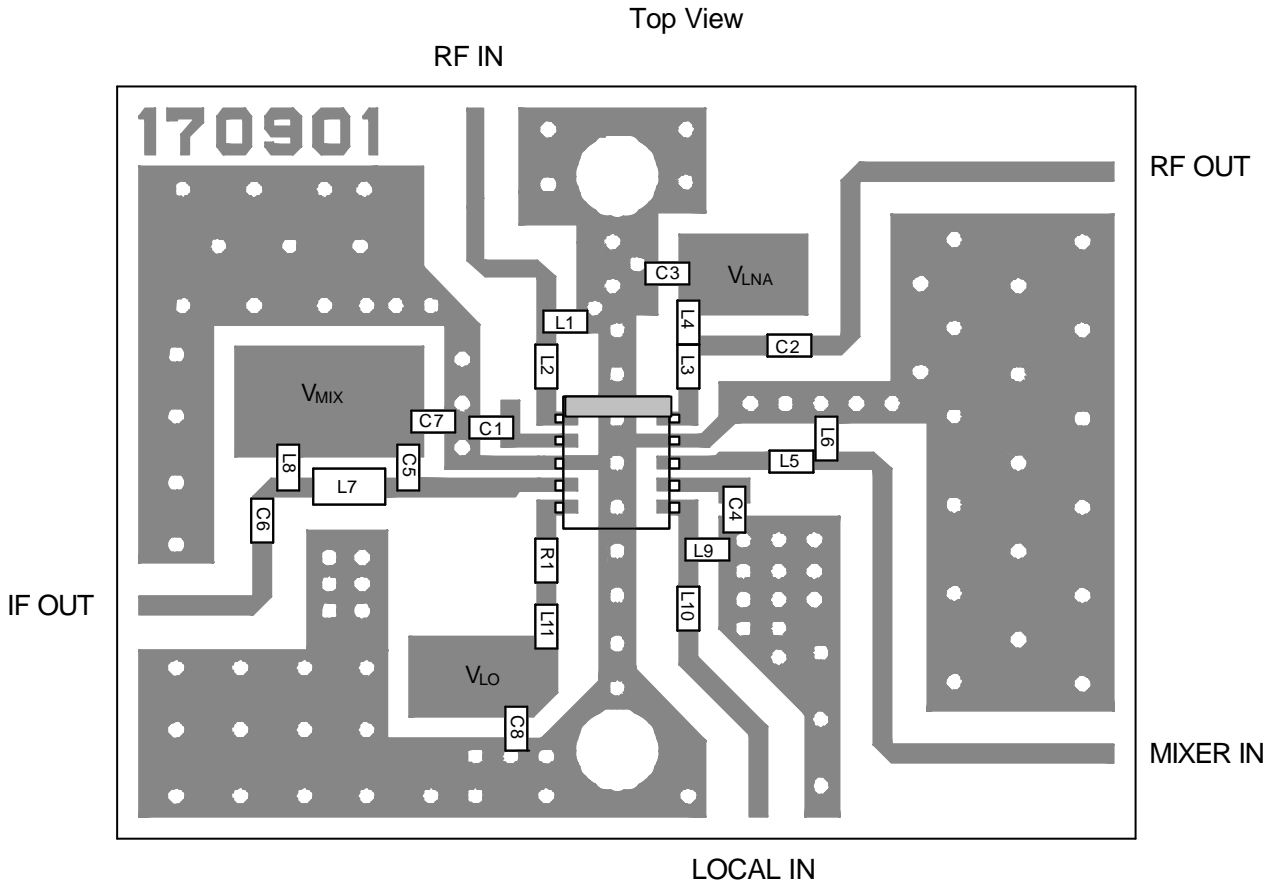

PCB (FR-4) : t = 0.2 mm

MICRO STRIPLINE WIDTH = 0.4 mm ($Z_0 = 50\Omega$)

PCB SIZE = 23.0 x 17.0 mm

MEASURING BLOCK DIAGRAM

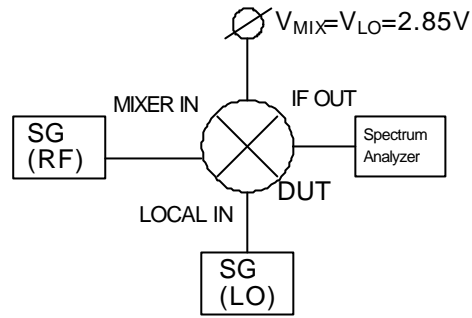

Conversion Gain Measurement Block Diagram

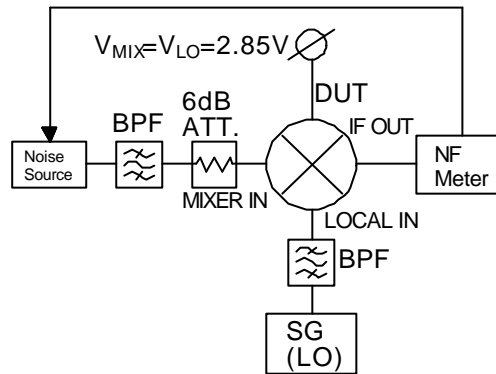

Noise Figure Measurement Block Diagram

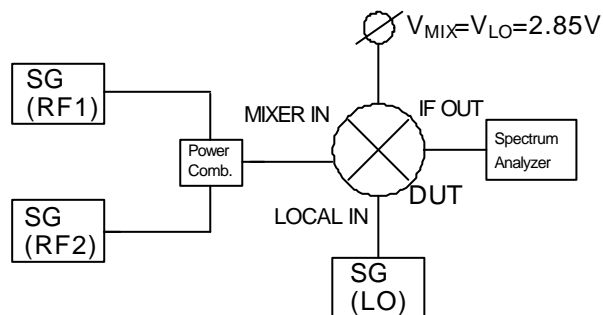

IF,IM3 Measurement Block Diagram

NJG1715KC1

■ PACKAGE OUTLINE (FLP10-C1)

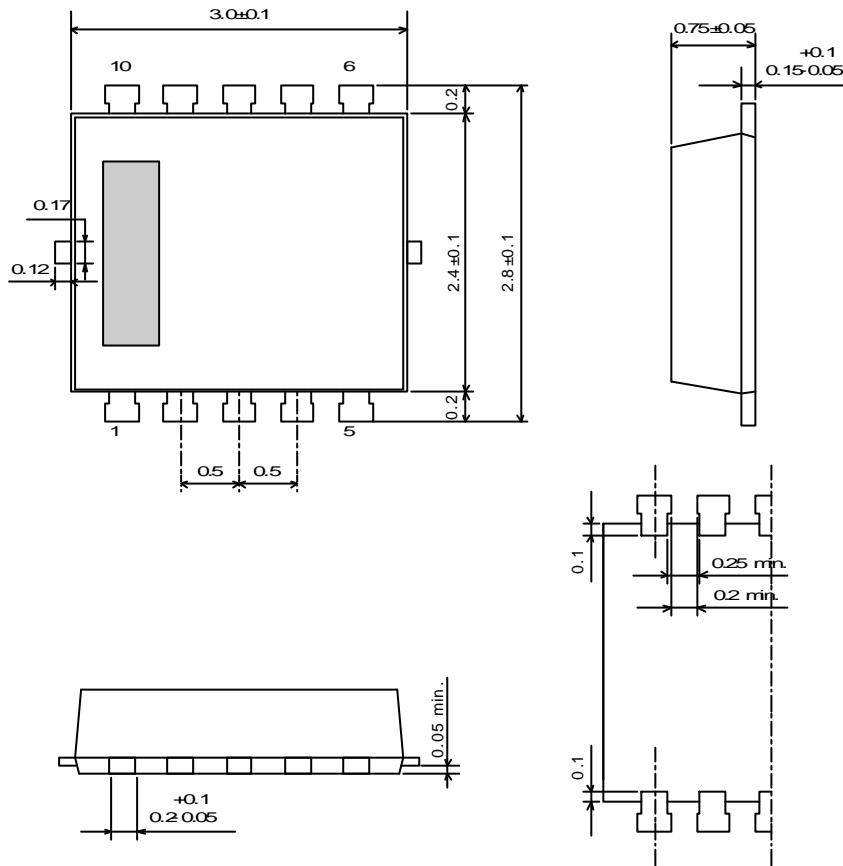

Lead material	: Copper
Lead surface finish	: Solder plating
Molding material	: Epoxy resin
UNIT	: mm
Weight	: 15mg

Cautions on using this product

This product contains Gallium-Arsenide (GaAs) which is a harmful material.

- Do NOT eat or put into mouth.
- Do NOT dispose in fire or break up this product.
- Do NOT chemically make gas or powder with this product.
- To waste this product, please obey the relating law of your country.

[CAUTION]

The specifications on this databook are only given for information, without any guarantee as regards either mistakes or omissions. The application circuits in this databook are described only to show representative usages of the product and not intended for the guarantee or permission of any right including the industrial rights.

This product may be damaged with electric static discharge (ESD) or spike voltage. Please handle with care to avoid these damages.