

Approved	Approved	Charged
		H.Koyanagi

Specification of uncooled DFB-LD module

Module type: FU-445SDF-x1Mxx
(Mitsubishi standard product)

A	B	C	D
	x		
Date		Approved	
20.Jun.'01		Y.Hozumi	

MITSUBISHI ELECTRIC CORPORATION

* Mitsubishi Electric Corp. reserves the right to change product design and specification without notice.

MITSUBISHI (OPTICAL DEVICES)

FU-445SDF-x1Mxx**1.3 mm UNCOOLED DFB-LD MODULE WITH SINGLEMODE FIBER PIGTAIL
(BIAS CIRCUIT INTEGRATED, DIGITAL APPLICATION)****DESCRIPTION**

Module type FU-445SDF-x1Mxx is a 1.3 μ m Uncooled DFB-LD module with single-mode optical fiber.

This module is suitable to a light source for use in 2.5Gb/s digital optical communication systems.

FEATURES

- $\lambda/4$ shifted Multi quantum wells (MQW) DFB Laser Diode module
- Input impedance is 25 Ω
- Emission wavelength is in 1.3 μ m band
- High-speed response
- Built-in optical isolator
- Built-in thermistor and bias T
- 8-pin Mini-DIL package with Gull wing leads
- With photodiode for optical output monitor

APPLICATION

High speed transmission systems (~2.5Gb/s)

ABSOLUTE MAXIMUM RATINGS (T_c=25°C)

Parameter		Symbol	Conditions	Rating	Unit
Laser diode	Optical output power	Pf	CW	6	mW
	Forward current	If	CW	100	mA
	Reverse voltage	Vrl	-	2	V
Photodiode	Reverse voltage	Vrd	-	20	V
	Forward current	Ifd	-	2	mA
Operating case temperature		Tc	-	-20 ~ +85	°C
Storage temperature		Tstg	-	-40 ~ +85	°C

MITSUBISHI (OPTICAL DEVICES)

FU-445SDF-x1Mxx**1.3 mm UNCOOLED DFB-LD MODULE WITH SINGLEMODE FIBER PIGTAIL
(BIAS CIRCUIT INTEGRATED, DIGITAL APPLICATION)****ELECTRICAL/OPTICAL CHARACTERISTICS** (Tc=-20~85°C, unless otherwise noted)

Parameter	Symbol	Test Conditions	Limits			Unit
			Min.	Typ.	Max.	
Threshold current	I _{th}	CW, T _c =25°C	-	10	25	mA
		CW	2	-	40	
Optical output power at threshold current	P _{th}	CW, I _{bias} =I _{th}	-	-	50	μW
Operating current	I _{op}	CW, P _f =2mW, T _c =25°C	-	40	70	mA
		CW, P _f =2mW, T _c =85°C	-	60	90	
Operating voltage	V _{op}	CW, P _f =2mW, T _c =25°C	-	1.2	1.5	V
		CW, P _f =2mW, T _c =85°C	-	1.6	1.8	
Input impedance	Z _{in}	-	-	25	-	Ω
Optical output power from fiber end	P _f	CW, nominal	-	2	-	mW
Light-emission central wavelength	λ _c	CW, P _f =1mW	1290	1310	1330	nm
Wavelength temperature coefficient	λ _{ct}	-	-	0.09	0.1	nm/°C
Spectral width	Δλ	(Note1), -20dB	-	-	0.8	nm
Side mode suppression ratio	S _r	(Note1)	30	45	-	dB
Cutoff frequency (-1.5dB optical)	f _c	P _f =1mW	3.5	-	-	GHz
Rise and fall time (10~90%)	t _r , t _f	(Note1)	-	125	150	psec
Dispersion penalty	P _p	(Note1), -300ps/nm disp.	-	-	0.5	dB
Relative intensity noise	N _r	CW, P _f =1mW, f=1GHz	-	-145	-130	dB/Hz
Tracking error (Note 2)	E _r	CW, APC(I _{mon} =const.)	-	0.5	1.25	dB
Differential efficiency	η	CW, T _c =25°C	0.06	-	0.2	mW/ mA
		CW	0.04	-	0.27	
Monitor current	I _{mon}	CW, P _f =1mW, V _{rd} =5V	0.05	-	1	mA
Optical isolation	I _{so}	-	20	-	-	dB
Dark current (PD)	I _d	V _{rd} =5V	-	-	0.1	μA
Capacitance (PD)	C _t	V _{rd} =5V, f=1MHz	-	-	10	pF
Thermistor resistance	R _{th}	T _c =25°C	9.5	10	10.5	kΩ
B constant of R _{th}	B	-	-	3950	-	K

Note 1) 2.48832Gb/s NRZ, 2²³-1, P_{f_ave}=1mW, I_{bias}=I_{th}, optical return loss from the line should be greater than 24dB in order to ensure the specified performance.

Note 2) E_r=max|10×log(P_f / P_f@25°C)|

FIBER PIGTAIL SPECIFICATIONS

Parameter	Limits	Unit
Type	SM	-
Mode field diameter	9.3±1	μm
Cladding diameter	125±2	μm
Secondary coating outer diameter	0.9±0.1	mm
Connector	See Table 1.	-
Optical return loss of connector	40 (min)	dB

MITSUBISHI (OPTICAL DEVICES)

FU-445SDF-x1Mxx**1.3 mm UNCOOLED DFB-LD MODULE WITH SINGLEMODE FIBER PIGTAIL
(BIAS CIRCUIT INTEGRATED, DIGITAL APPLICATION)****DOCUMENTATION**

- Threshold current (I_{th}) at T_c=25, 85°C
- Operating current (I_{op}) at T_c=25, 85°C
- Operating voltage (V_{op}) at T_c=25°C
- Light-emission central wavelength (λ_c) at T_c=25°C
- Monitor current (I_{mon}) at T_c=25°C
- Optical output power from fiber end (P_f)

Table 1.

Type number	Connector type	L (Note 3)	Outline diagram
FU-445SDF-1M1C	None (Note 4)	-	(1)
FU-445SDF-V1M1C	FC/PC	28.4	
FU-445SDF-W1M1C	SC/PC	34.5	
FU-445SDF-1M2B	None (Note 4)	-	(2)
FU-445SDF-V1M2B	FC/PC	28.4	
FU-445SDF-W1M2B	SC/PC	34.5	

Note 3) 'L' is defined in OUTLINE DIAGRAMS.

Note 4) There are some cases where a connector for testing is shipped with the product.
Then the fiber length not including the connector is more than 1000mm.

MITSUBISHI (OPTICAL DEVICES)

FU-445SDF-x1Mxx

1.3 mm UNCOOLED DFB-LD MODULE WITH SINGLEMODE FIBER PIGTAIL
(BIAS CIRCUIT INTEGRATED, DIGITAL APPLICATION)

OUTLINE DIAGRAM (1)

(Unit : mm)

NOTES 1. TOLERANCES UNLESS NOTED ±0.3

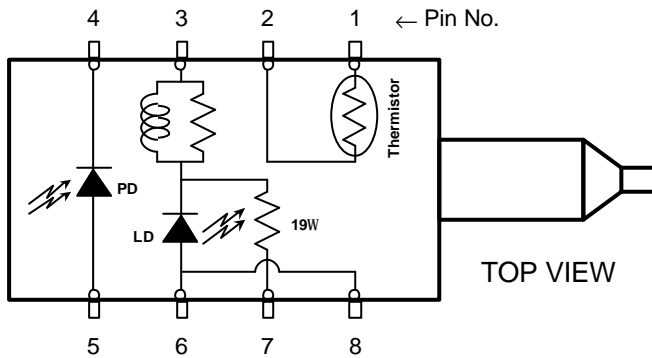
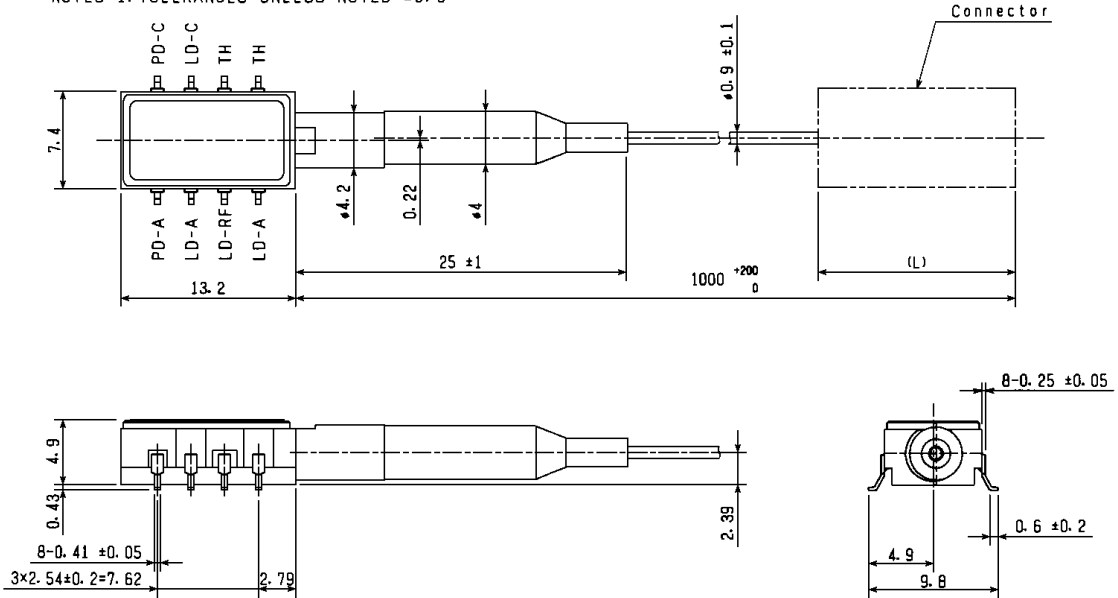

PIN	FUNCTION
1	THERMISTOR
2	THERMISTOR
3	LD BIAS, CATHODE
4	PD CATHODE
5	PD ANODE
6	LD ANODE
7	LD RF, CATHODE
8	LD ANODE

FU-445SDF-x1M1C

MITSUBISHI (OPTICAL DEVICES)

FU-445SDF-x1Mxx**1.3 mm UNCOOLED DFB-LD MODULE WITH SINGLEMODE FIBER PIGTAIL
(BIAS CIRCUIT INTEGRATED, DIGITAL APPLICATION)****OUTLINE DIAGRAM (2)**

(Unit : mm)

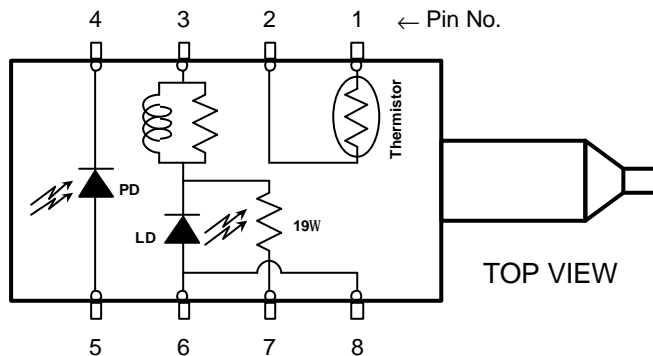
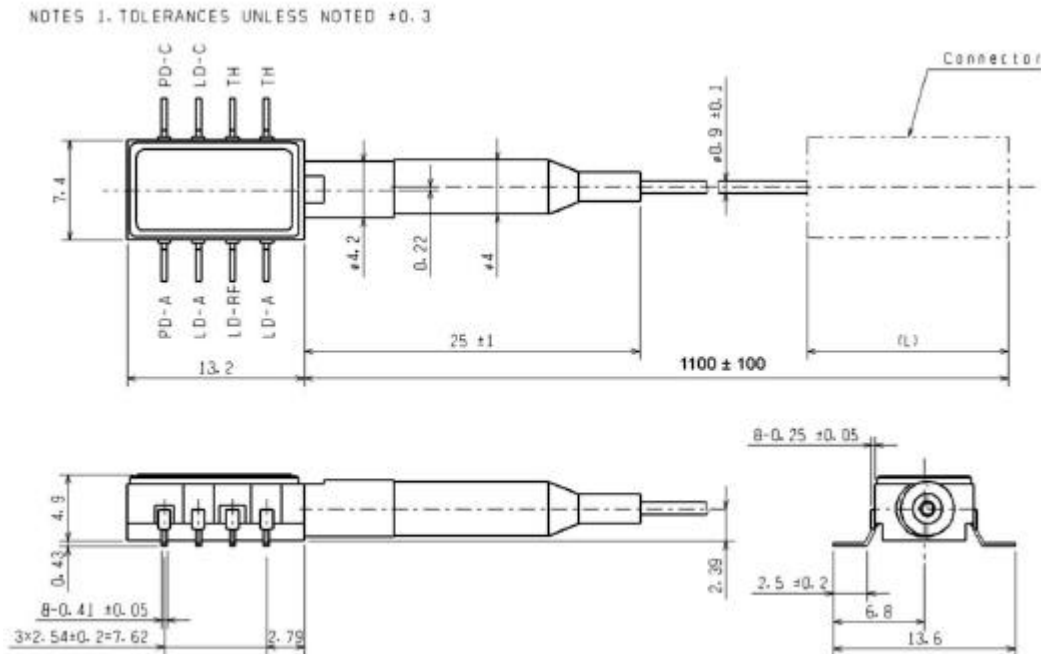

PIN	FUNCTION
1	THERMISTOR
2	THERMISTOR
3	LD BIAS, CATHODE
4	PD CATHODE
5	PD ANODE
6	LD ANODE
7	LD RF, CATHODE
8	LD ANODE

FU-445SDF-x1M2B