

# Wireless Bipolar Power Transistor, 30W

## 1.6 - 1.7 GHz

PH1617-30

V2.00

### Features

- Designed for Linear Amplifier Applications
- -30 dBc Typ 3rd IMD at 30 Watts PEP
- Common Emitter Class AB Operation
- Internal Input Impedance Matching
- Diffused Emitter Ballasting

### Absolute Maximum Ratings at 25°C

Parameter	Symbol	Rating	Units
Collector-Base Voltage	$V_{CBC}$	60	V
Collector-Emitter Voltage	$V_{CES}$	60	V
Emitter-Base Voltage	$V_{EBD}$	3.0	V
Collector Current	$I_C$	10	A
Power Dissipation	$P_D$	109	W
Junction Temperature	$T_J$	200	°C
Storage Temperature	$T_{STG}$	-55 to +150	°C
Thermal Resistance	$\theta_{JC}$	1.6	°C/W

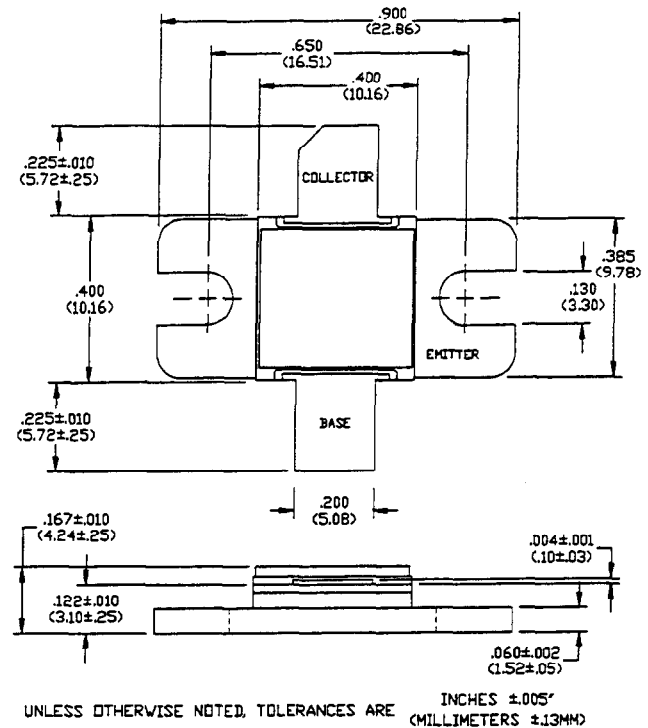

### Electrical Characteristics at 25°C

Parameter	Symbol	Min	Max	Units	Test Conditions
Collector-Emitter Breakdown Voltage	$BV_{CES}$	60	-	V	$I_C=40$ mA
Collector-Emitter Leakage Current	$I_{CES}$	-	4.0	mA	$V_{CE}=25$ V
Collector-Emitter Breakdown Voltage	$BV_{CEO}$	20	-	V	$I_C=40$ mA
Collector-Emitter Breakdown Voltage	$BV_{CER}$	30	-	V	$I_C=40$ mA, $R_{BE}=220 \Omega$
Emitter-Base Breakdown Voltage	$BV_{EBD}$	3.0	-	V	$I_B=40$ mA
DC Forward Current Gain	$h_{FE}$	15	120	-	$V_{CE}=5$ V, $I_C=2$ A
Power Gain	$G_p$	10	-	dB	$V_{CC}=25$ V, $I_{CO}=200$ mA, $P_{OUT}=30$ W PEP, $F=1.6, 1.65, 1.70$ GHz
Collector Efficiency	$\eta_C$	40	-	%	$V_{CC}=25$ V, $I_{CO}=200$ mA, $P_{OUT}=30$ W PEP, $F=1.6, 1.65, 1.70$ GHz
Input Return Loss	RL	10	-	dB	$V_{CC}=25$ V, $I_{CO}=200$ mA, $P_{OUT}=30$ W PEP, $F=1.6, 1.65, 1.70$ GHz
Load Mismatch Tolerance	VSWR-T	-	3.0:1	-	$V_{CC}=25$ V, $I_{CO}=200$ mA, $P_{OUT}=30$ W PEP, $F=1.6, 1.65, 1.70$ GHz
3rd Order IMD	$IMD_3$	-	-28	dBc	$V_{CC}=25$ V, $I_{CO}=20$ mA, $P_{OUT}=30$ W PEP, $F=1650$ MHz, $\Delta F=100$ kHz

### Typical Optimum Device Impedances

F(GHz)	$Z_{IN}(\Omega)$	$Z_{LOAD}(\Omega)$
1.60	$2.1 + j4.9$	$1.3 - j0.7$
1.65	$3.1 + j3.8$	$1.2 - j0.8$
1.70	$2.1 + j3.5$	$1.2 - j0.9$

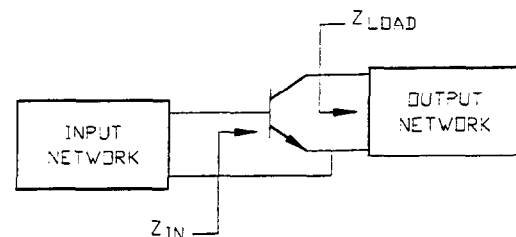

RF Test Fixture

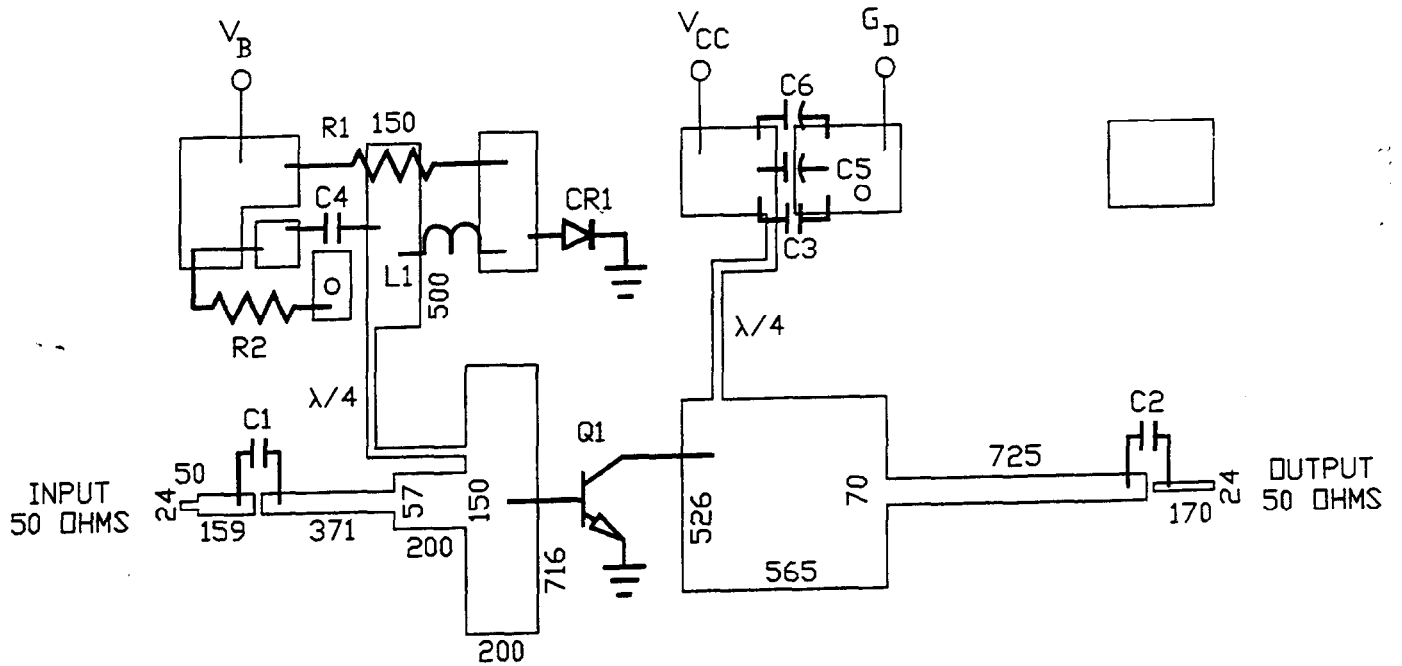

ARTWORK DIMENSIONS IN MILS

PARTS LIST

C1	C2	C3	33 pF ATC SIZE A
C4			6.8 uF 35 VOLTS CHIP
C5			4.7 uF 35 VOLTS CHIP
C6			50 uF 50 VOLTS
CR1			1N4245 DIODE
Q1			PH1617-30
R1			5Ω 1/4 WATT
R2			2.2Ω 1/8 WATT CHIP
L1			10 T/NO. 24 AWG ON 1/8" DIAMETER
BOARD TYPE: ROGERS 6010.5 25 MILS THICK, ER = 10.5			

Typical Broadband Performance Curves

