

# Flange Mounted Double-Balanced Mixers

DMI-18A

## Features

- 5.0 dB Midband Conversion Loss
- 28 dB Midband L-R Isolation

## Description

This mixer is typically specified as a down converter. It also functions well as an up converter, third harmonic mixer or phase detector.

## Environmental

Parameter	
Operating Temp. Max.	-55°C to +85°C
Storage Temp. Max.	-65°C to +125°C
Humidity	95% non-condensing
Vibration	7G's rms, 50 to 2000 cps, per MIL-STD-810-B, Method 514, Procedure 5

## OUTLINE DRAWING

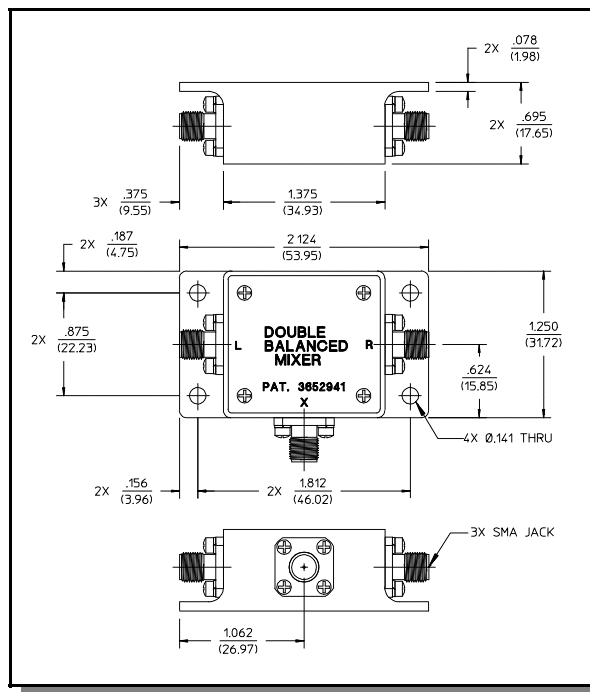

## Electrical Specifications: $T_A = 25^\circ\text{C}$

RF Frequency Range (GHz)	L-R Isolation (dB)	L-I Isolation (dB)	3 dB IF Bandwidth (GHz)	LO Range (dBm) Min/Max	Conversion Loss (dB) <sup>2</sup> Typ/Max	Input 1dB Compression Point (dBm)	Noise Figure SSB (dB Max.)
1.0 - 18.0	22	18	DC - 0.5	7/11	6.0/9.5	+3	10.0

1. Specifications apply when operated at +8 dBm available LO power with 50 ohm source and load impedance.
2. For IF Frequencies of 100 MHz and RF power of -10 dBm or lower.

## Typical Performance Curves 25°

**Conversion Loss**

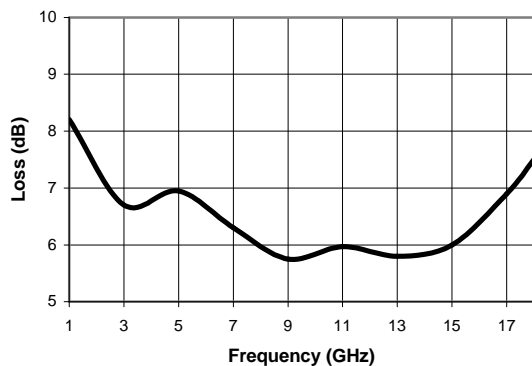

**Isolation**

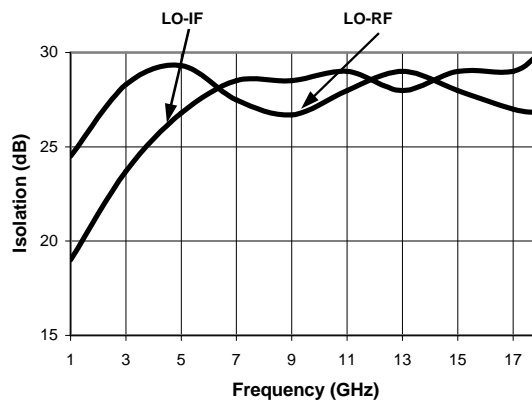

Typical Performance Curves 25°

*IF Port Response*

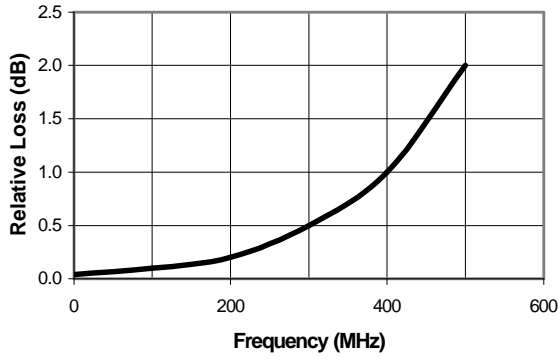

Ordering Information

Part Number	Package
DMI-18A	Bulk Packaging

Specifications subject to change without notice.

- North America: Tel. (800) 366-2266
- Asia/Pacific: Tel.+81-44-844-8296, Fax +81-44-844-8298
- Europe: Tel. +44 (1344) 869 595, Fax+44 (1344) 300 020

Visit [www.macom.com](http://www.macom.com) for additional data sheets and product information.

