



Integrated Power Hybrid IC for
Appliance Motor Drive Applications

IRAMX20UP60A

iMOTION™ Series

20A, 600V

with open Emitter Pins

Description

International Rectifier's IRAMX20UP60A is a 20A, 600V Integrated Power Hybrid IC for Appliance Motor Drives applications such as air conditioning systems and compressor drivers as well as in light industrial application. IR's technology offers an extremely compact, high performance AC motor-driver in a single isolated package to simplify design.

This advanced HIC is a combination of IR's low $V_{CE(on)}$ Punch-Through IGBT technology and the industry benchmark 3 phase high voltage, high speed driver in a fully isolated thermally enhanced package.

A built-in temperature monitor and input logic protection function, along with the short-circuit rated IGBTs and integrated under-voltage lockout function, deliver high level of protection and fail-safe operation. Using a Single in line package (SiP2) with heatspreader for the power die along with full transfer mold structure minimizes PCB space and resolves isolation problems to heatsink.

Features

- Integrated Gate Drivers
- Temperature Monitor
- Overcurrent shutdown
- Fully Isolated Package
- Low VCE (on) Non Punch Through IGBT Technology.
- Undervoltage lockout for all channels
- Matched propagation delay for all channels
- 5V Schmitt-triggered input logic
- Cross-conduction prevention logic
- Lower di/dt gate driver for better noise immunity
- Motor Power range 0.75~1.5kW / 85~253 Vac
- Isolation 2000V_{RMS} min



Absolute Maximum Ratings

| Parameter | Description | Max. Value | Units |
|-------------------------|---|-------------|------------------|
| V_{CES} / V_{RRM} | IGBT/Diode Blocking Voltage | 600 | V |
| V^+ | Positive Bus Input Voltage | 450 | |
| $I_O @ T_C=25^\circ C$ | RMS Phase Current (Note 1) | 20 | A |
| $I_O @ T_C=100^\circ C$ | RMS Phase Current (Note 1) | 10 | |
| I_O | Pulsed RMS Phase Current (Note 2) | 30 | |
| F_{PWM} | PWM Carrier Frequency | 20 | kHz |
| P_d | Power dissipation per IGBT @ $T_C = 25^\circ C$ | 38 | W |
| V_{ISO} | Isolation Voltage (1min) | 2000 | V _{RMS} |
| T_J (IGBT & Diodes) | Operating Junction temperature Range | -40 to +150 | °C |
| T_J (Driver IC) | Operating Junction temperature Range | -40 to +150 | |
| T | Mounting torque Range (M3 screw) | 0.5 to 0.6 | Nm |

Note 1: Sinusoidal Modulation at $V^+=400V$, $T_J=150^\circ C$, $F_{PWM}=16kHz$, Modulation Depth=0.8, PF=0.6, See Figure 3.

Note 2: $t_p < 100ms$; $T_C=25^\circ C$; $F_{PWM}=16kHz$.

IRAMX20UP60A

Internal Electrical Schematic - IRAMX20UP60B

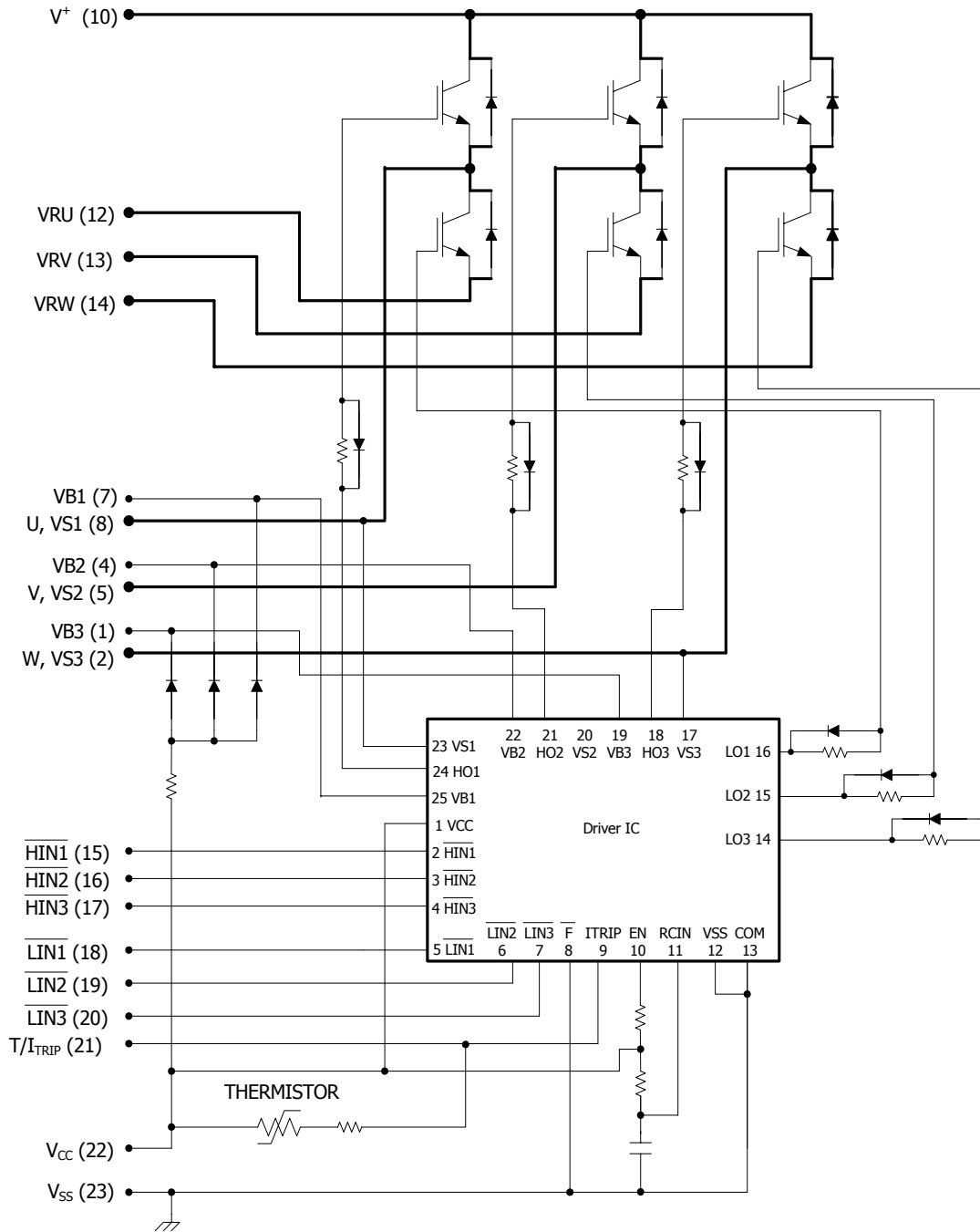

Absolute Maximum Ratings (Continued)

All voltages are absolute referenced to COM.

| Symbol | Parameter | Min | Max | Units | Conditions |
|-----------------------|--|-------------------|--|-------|--|
| I_{BDF} | Bootstrap Diode Peak Forward Current | --- | 4.5 | A | $t_p = 10\text{ms}$, $T_J = 150^\circ\text{C}$, $T_C = 100^\circ\text{C}$ |
| $P_{BR \text{ Peak}}$ | Bootstrap Resistor Peak Power (Single Pulse) | --- | 25.0 | W | $t_p = 100\mu\text{s}$, $T_C = 100^\circ\text{C}$ ESR / ERJ series |
| $V_{S1,2,3}$ | High Side floating supply voltage | $V_{B1,2,3} - 25$ | $V_{B1,2,3} + 0.3$ | V | |
| $V_{B1,2,3}$ | High Side floating supply voltage | -0.3 | 600 | V | |
| V_{CC} | Low Side and logic fixed supply voltage | -0.3 | 20 | V | |
| V_{IN} | Input voltage LIN, HIN, T/I _{Tripp} | -0.3 | Lower of ($V_{SS} + 15\text{V}$) or $V_{CC} + 0.3\text{V}$ | V | |

Inverter Section Electrical Characteristics @ $T_J = 25^\circ\text{C}$

| Symbol | Parameter | Min | Typ | Max | Units | Conditions |
|---------------------------------|---|-----|------|---------|---------------------|---|
| $V_{(BR)CES}$ | Collector-to-Emitter Breakdown Voltage | 600 | --- | --- | V | $V_{IN} = 5\text{V}$, $I_C = 250\mu\text{A}$ |
| $\Delta V_{(BR)CES} / \Delta T$ | Temperature Coeff. Of Breakdown Voltage | --- | 0.3 | --- | V/ $^\circ\text{C}$ | $V_{IN} = 5\text{V}$, $I_C = 1.0\text{mA}$ ($25^\circ\text{C} - 150^\circ\text{C}$) |
| $V_{CE(ON)}$ | Collector-to-Emitter Saturation Voltage | --- | 1.75 | 2.15 | V | $I_C = 10\text{A}$, $V_{CC} = 15\text{V}$ |
| | | --- | 2.10 | 2.60 | | $I_C = 10\text{A}$, $V_{CC} = 15\text{V}$, $T_J = 150^\circ\text{C}$ |
| I_{CES} | Zero Gate Voltage Collector Current | --- | 5 | 80 | μA | $V_{IN} = 5\text{V}$, $V^+ = 600\text{V}$ |
| | | --- | 165 | --- | | $V_{IN} = 5\text{V}$, $V^+ = 600\text{V}$, $T_J = 150^\circ\text{C}$ |
| V_{FM} | Diode Forward Voltage Drop | --- | 1.90 | 2.60 | V | $I_C = 10\text{A}$ |
| | | --- | 1.50 | 2.20 | | $I_C = 10\text{A}$, $T_J = 150^\circ\text{C}$ |
| V_{BDFM} | Bootstrap Diode Forward Voltage Drop | -- | -- | 1.25 | V | $I_F = 1\text{A}$ |
| | | --- | --- | 1.10 | | $I_F = 1\text{A}$, $T_J = 125^\circ\text{C}$ |
| R_{BR} | Bootstrap Resistor Value | --- | 22 | --- | Ω | |
| $\Delta R_{BR} / R_{BR}$ | Bootstrap Resistor Tolerance | --- | --- | ± 5 | % | |

IRAMX20UP60A



Inverter Section Switching Characteristics @ $T_J = 25^\circ\text{C}$

| Symbol | Parameter | Min | Typ | Max | Units | Conditions |
|-----------|-----------------------------------|-------------|-----|------|---------------|--|
| E_{ON} | Turn-On Switching Loss | --- | 390 | 490 | μJ | $I_C=10\text{A}$, $V^+=400\text{V}$ $V_{CC}=15\text{V}$, $L=2\text{mH}$ Energy losses include "tail" and diode reverse recovery See CT1 |
| E_{OFF} | Turn-Off Switching Loss | --- | 150 | 200 | | |
| E_{TOT} | Total Switching Loss | --- | 540 | 690 | | |
| E_{REC} | Diode Reverse Recovery energy | --- | 35 | 70 | | |
| t_{RR} | Diode Reverse Recovery time | --- | 100 | --- | ns | See CT1 |
| E_{ON} | Turn-on Switching Loss | --- | 620 | 780 | μJ | $I_C=10\text{A}$, $V^+=400\text{V}$ $V_{CC}=15\text{V}$, $L=2\text{mH}$, $T_J=150^\circ\text{C}$ Energy losses include "tail" and diode reverse recovery See CT1 |
| E_{OFF} | Turn-off Switching Loss | --- | 305 | 400 | | |
| E_{TOT} | Total Switching Loss | --- | 925 | 1180 | | |
| E_{REC} | Diode Reverse Recovery energy | --- | 65 | 135 | | |
| t_{RR} | Diode Reverse Recovery time | --- | 130 | --- | ns | See CT1 |
| Q_G | Turn-On IGBT Gate Charge | --- | 56 | 84 | nC | $I_C=15\text{A}$, $V^+=400\text{V}$, $V_{GE}=15\text{V}$ |
| RBSOA | Reverse Bias Safe Operating Area | FULL SQUARE | | | | $T_J=150^\circ\text{C}$, $I_C=10\text{A}$, $V_P=600\text{V}$ $V^+=450\text{V}$ $V_{CC}=+15\text{V}$ to 0V See CT3 |
| SCSOA | Short Circuit Safe Operating Area | 10 | --- | --- | μs | $T_J=150^\circ\text{C}$, $V_P=600\text{V}$, $V^+=360\text{V}$, $V_{CC}=+15\text{V}$ to 0V See CT2 |
| I_{CSC} | Short Circuit Collector Current | --- | 140 | --- | A | $T_J=150^\circ\text{C}$, $V_P=600\text{V}$, $t_{SC}<10\mu\text{s}$ $V^+=360\text{V}$, $V_{GE}=15\text{V}$ $V_{CC}=+15\text{V}$ to 0V See CT2 |

Recommended Operating Conditions Driver Function

The Input/Output logic timing diagram is shown in Figure 1. For proper operation the device should be used within the recommended conditions. All voltages are absolute referenced to COM. The V_S offset is tested with all supplies biased at 15V differential (Note 3)

| Symbol | Definition | Min | Max | Units |
|--------------|--|----------|------------|-------|
| $V_{B1,2,3}$ | High side floating supply voltage | V_S+12 | V_S+20 | V |
| $V_{S1,2,3}$ | High side floating supply offset voltage | Note 4 | 450 | |
| V_{CC} | Low side and logic fixed supply voltage | 12 | 20 | V |
| $V_{T/TRIP}$ | T/I_{TRIP} input voltage | V_{SS} | $V_{SS}+5$ | V |
| V_{IN} | Logic input voltage LIN, HIN | V_{SS} | $V_{SS}+5$ | |

Note 3: For more details, see IR21365 data sheet

Note 4: Logic operational for V_S from COM-5V to COM+600V. Logic state held for V_S from COM-5V to COM- V_{BS} . (please refer to DT97-3 for more details)

Static Electrical Characteristics Driver Function

V_{BIAS} (V_{CC} , $V_{BS1,2,3}$)=15V, unless otherwise specified. The V_{IN} and I_{IN} parameters are referenced to COM and are applicable to all six channels. (Note 3)

| Symbol | Definition | Min | Typ | Max | Units |
|-----------------------------|---|------|------|------|---------|
| V_{IH} | Logic "0" input voltage | 3.0 | --- | --- | V |
| V_{IL} | Logic "1" input voltage | --- | --- | 0.8 | V |
| V_{CCUV+} , V_{BSUV+} | V_{CC} and V_{BS} supply undervoltage Positive going threshold | 10.6 | 11.1 | 11.6 | V |
| V_{CCUV-} , V_{BSUV-} | V_{CC} and V_{BS} supply undervoltage Negative going threshold | 10.4 | 10.9 | 11.4 | V |
| V_{CCUVH} , V_{BSUVH} | V_{CC} and V_{BS} supply undervoltage lock-out hysteresis | --- | 0.2 | --- | V |
| $V_{IN, clamp}$ | Input Clamp Voltage (HIN, LIN, T/I _{TRIP}) $I_{IN}=10\mu A$ | 4.9 | 5.2 | 5.5 | V |
| I_{QBS} | Quiescent V_{BS} supply current $V_{IN}=0V$ | --- | --- | 165 | μA |
| I_{QCC} | Quiescent V_{CC} supply current $V_{IN}=0V$ | --- | --- | 3.35 | mA |
| I_{LK} | Offset Supply Leakage Current | --- | --- | 60 | μA |
| I_{IN+} | Input bias current $V_{IN}=5V$ | --- | 200 | 300 | μA |
| I_{IN-} | Input bias current $V_{IN}=0V$ | --- | 100 | 220 | μA |
| T/I _{TRIP+} | T/I _{TRIP} bias current $V_{ITRIP}=5V$ | --- | 30 | 100 | μA |
| T/I _{TRIP-} | T/I _{TRIP} bias current $V_{ITRIP}=0V$ | --- | 0 | 1 | μA |
| V(T/I _{TRIP}) | T/I _{TRIP} threshold Voltage | 3.85 | 4.30 | 4.75 | V |
| V(T/I _{TRIP} ,HYS) | T/I _{TRIP} Input Hysteresis | --- | 0.07 | --- | V |

IRAMX20UP60A

Thermal and Mechanical Characteristics

| Symbol | Parameter | Min | Typ | Max | Units | Conditions |
|---------------|-------------------------------|-----|-----|-----|-------|---|
| $R_{th(J-C)}$ | Thermal resistance, per IGBT | --- | 1.5 | 2.2 | °C/W | Flat, greased surface. Heatsink compound thermal conductivity 1W/mK |
| $R_{th(J-C)}$ | Thermal resistance, per Diode | --- | 5 | 5.5 | | |
| $R_{th(C-S)}$ | Thermal resistance, C-S | --- | 0.1 | --- | | |
| C_D | Creepage Distance | 3.2 | --- | --- | mm | See outline Drawings |

Internal NTC - Thermistor Characteristics

| Parameter | Definition | Min | Typ | Max | Units | Conditions |
|---------------------------|----------------------|------|------|------|------------|------------------------------------|
| R_{25} | Resistance | 97 | 100 | 103 | k Ω | $T_C = 25^\circ\text{C}$ |
| R_{125} | Resistance | 2.25 | 2.52 | 2.80 | k Ω | $T_C = 125^\circ\text{C}$ |
| B | B-constant (25-50°C) | 4165 | 4250 | 4335 | k | $R_2 = R_1 e^{[B(1/T_2 - 1/T_1)]}$ |
| Temperature Range | | -40 | | 125 | °C | |
| Typ. Dissipation constant | | | 1 | | mW/°C | $T_C = 25^\circ\text{C}$ |

Input-Output Logic Level Table

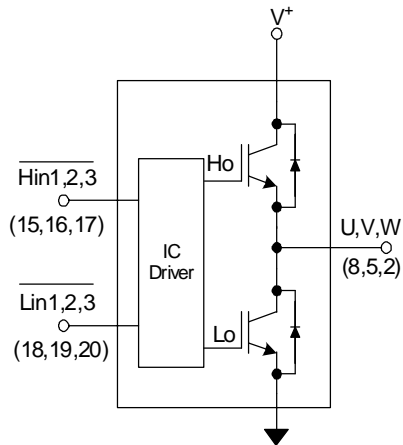

| T/I_{TRIP} | $\overline{\text{HIN}}_{1,2,3}$ | $\overline{\text{LIN}}_{1,2,3}$ | U,V,W |
|--------------|---------------------------------|---------------------------------|--------------|
| 0 | 0 | 1 | V^+ |
| 0 | 1 | 0 | 0 |
| 0 | 1 | 1 | Off |
| 1 | X | X | Off |

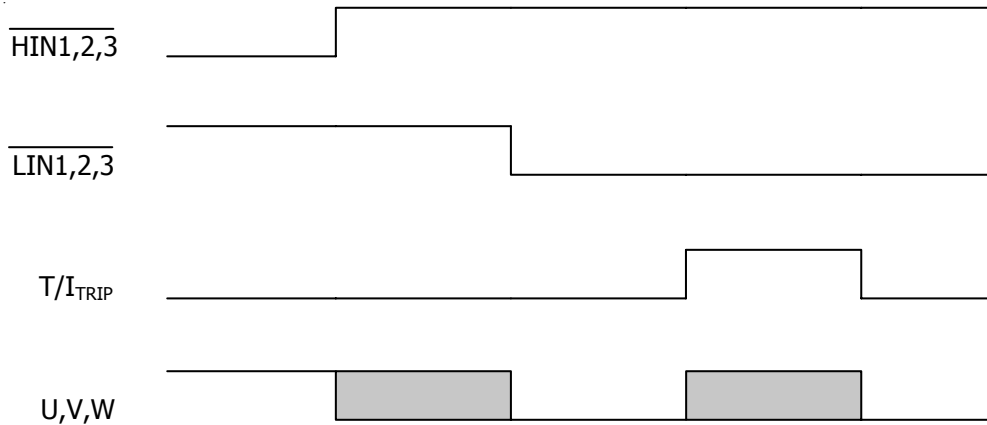

Figure1. Input/Output Timing Diagram

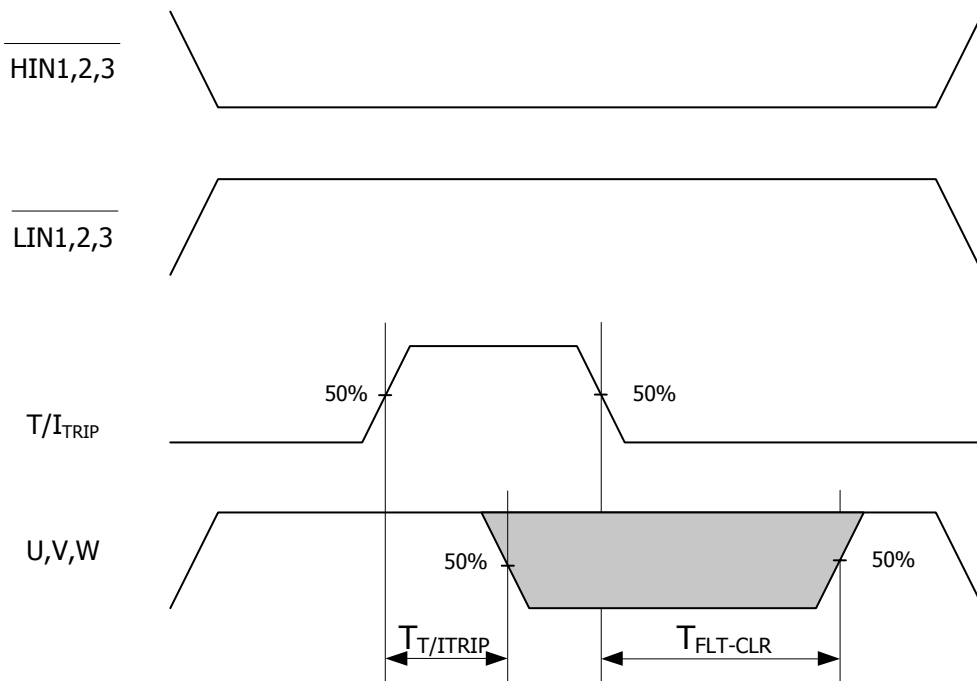

Figure 2. I_{Trip} Timing Waveform

Note 5: The shaded area indicates that both high-side and low-side switches are off and therefore the half-bridge output voltage would be determined by the direction of current flow in the load.

IRAMX20UP60A

Module Pin-Out Description

| Pin | Name | Description |
|-----|--------------|---|
| 1 | V_{B3} | High Side Floating Supply Voltage 3 |
| 2 | U, V_{S3} | Output 3 - High Side Floating Supply Offset Voltage |
| 3 | NA | none |
| 4 | V_{B2} | High Side Floating Supply voltage 2 |
| 5 | V, V_{S2} | Output 2 - High Side Floating Supply Offset Voltage |
| 6 | NA | none |
| 7 | V_{B1} | High Side Floating Supply voltage 1 |
| 8 | W, V_{S1} | Output 1 - High Side Floating Supply Offset Voltage |
| 9 | NA | none |
| 10 | V^+ | Positive Bus Input Voltage |
| 11 | NA | none |
| 12 | L_{E1} | Low Side Emitter Connection - Phase 1 |
| 13 | L_{E2} | Low Side Emitter Connection - Phase 2 |
| 14 | L_{E3} | Low Side Emitter Connection - Phase 3 |
| 15 | H_{IN1} | Logic Input High Side Gate Driver - Phase 1 |
| 16 | H_{IN2} | Logic Input High Side Gate Driver - Phase 2 |
| 17 | H_{IN3} | Logic Input High Side Gate Driver - Phase 3 |
| 18 | L_{IN1} | Logic Input Low Side Gate Driver - Phase 1 |
| 19 | L_{IN2} | Logic Input Low Side Gate Driver - Phase 2 |
| 20 | L_{IN3} | Logic Input Low Side Gate Driver - Phase 3 |
| 21 | T/I_{TRIP} | Temperature Monitor and Shut-down Pin |
| 22 | V_{CC} | +15V Main Supply |
| 23 | V_{SS} | Negative Main Supply |



Typical Application Connection IRAMX20UP60A

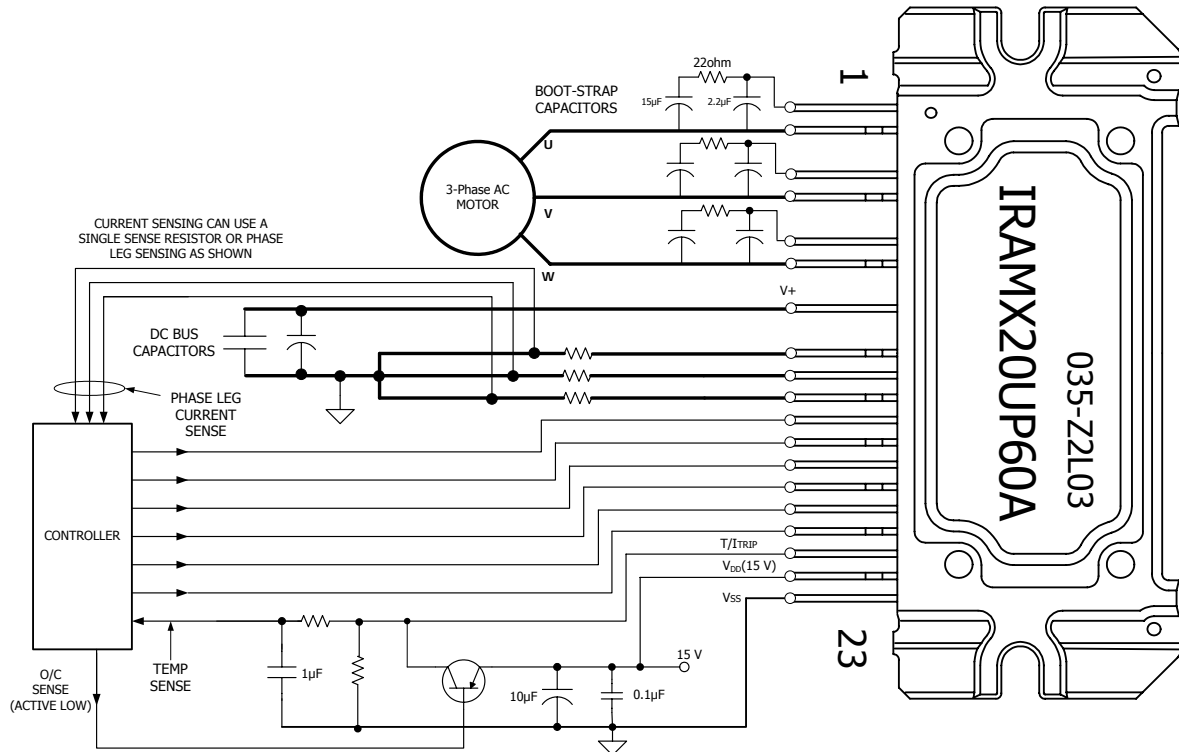

1. Electrolytic bus capacitors should be mounted as close to the module bus terminals as possible to reduce ringing and EMI problems. Additional high frequency ceramic capacitor mounted close to the module pins will further improve performance.
2. In order to provide good decoupling between $V_{CC}-V_{SS}$ and $V_{B1,2,3}-V_{S1,2,3}$ terminals, the capacitors shown connected between these terminals should be located very close to the module pins. Additional high frequency capacitors, typically $0.1\mu\text{F}$, are strongly recommended.
3. Value of the boot-strap capacitors depends upon the switching frequency. Their selection should be made based on IR design tip DN 98-2a, application note AN-1044 or Figure 9. Bootstrap capacitor value must be selected to limit the power dissipation of the internal resistor in series with the V_{CC} . (see maximum ratings Table on page 3).
4. Current sense signal can be obtained from pin 20 and pin 23.
5. After approx. 8ms the FAULT is reset. (see Dynamic Characteristics Table on page 5).
6. PWM generator must be disabled within Fault duration to guarantee shutdown of the system, overcurrent condition must be cleared before resuming operation.
7. Fault/Enable pin must be pulled-up to +5V.

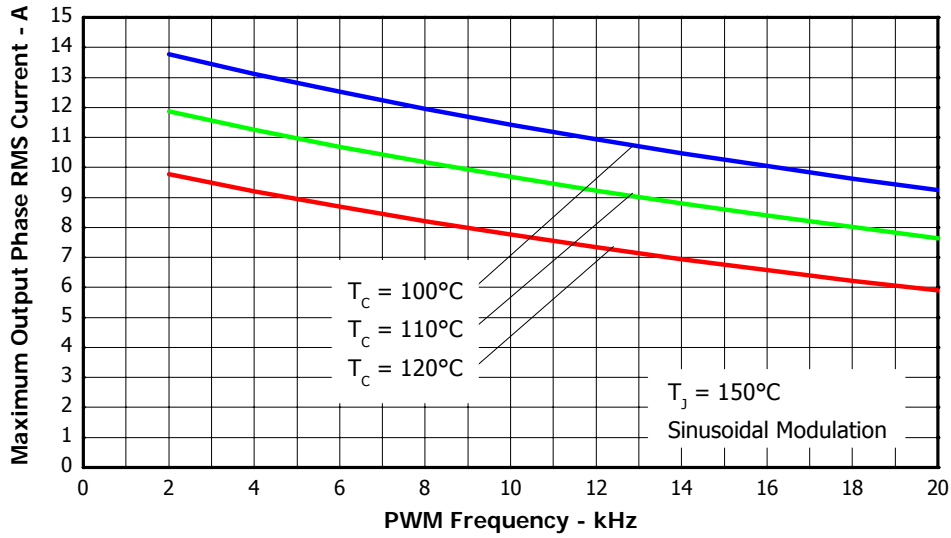

Figure 3. Maximum Sinusoidal Phase Current vs. PWM Switching Frequency
 $V^+=400\text{V}$, $T_J=150^\circ\text{C}$, Modulation Depth=0.8, PF=0.6

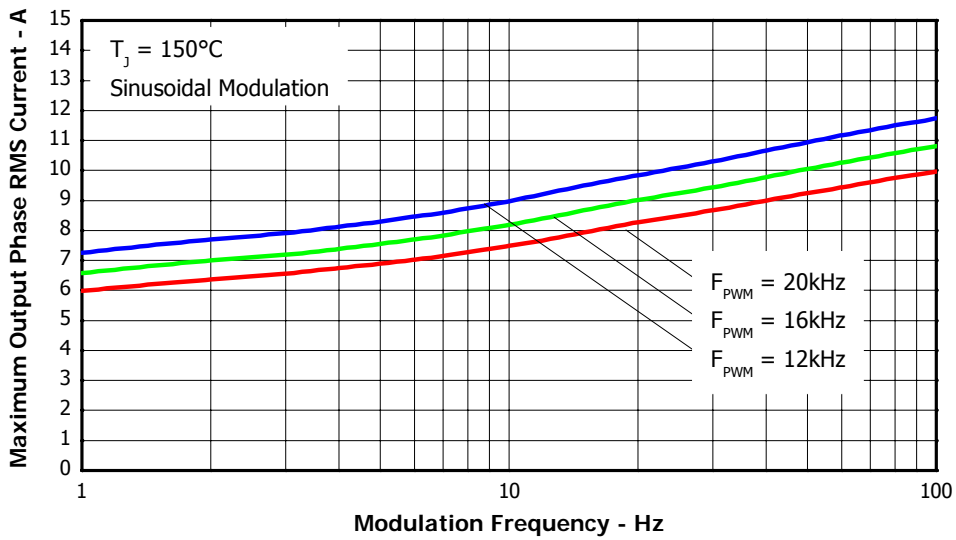

Figure 4. Maximum Sinusoidal Phase Current vs. Modulation Frequency
 $V^+=400\text{V}$, $T_J=150^\circ\text{C}$, $T_c=100^\circ\text{C}$, Modulation Depth=0.8, PF=0.6

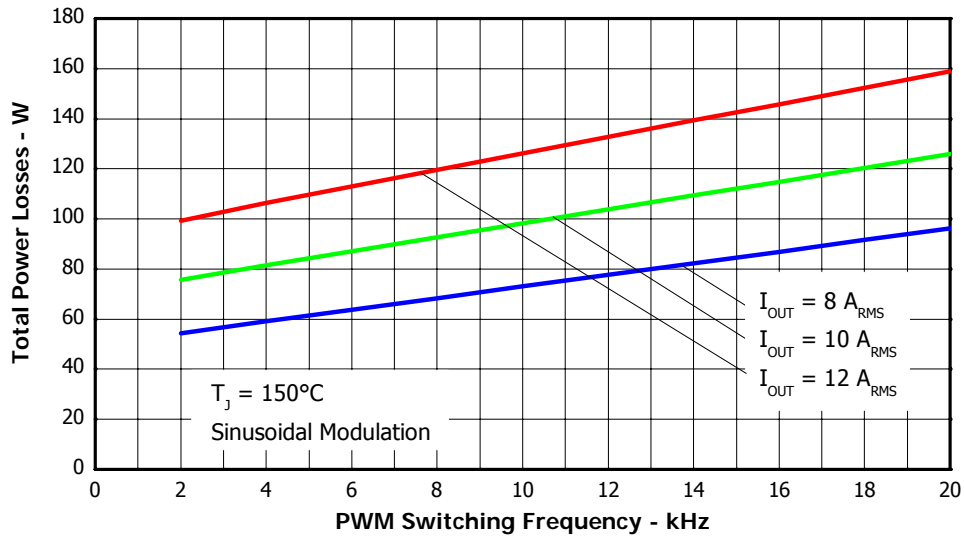

Figure 5. Total Power Losses vs. PWM Switching Frequency, Sinusoidal modulation
 $V^+=400\text{V}$, $T_j=150^\circ\text{C}$, Modulation Depth=0.8, PF=0.6

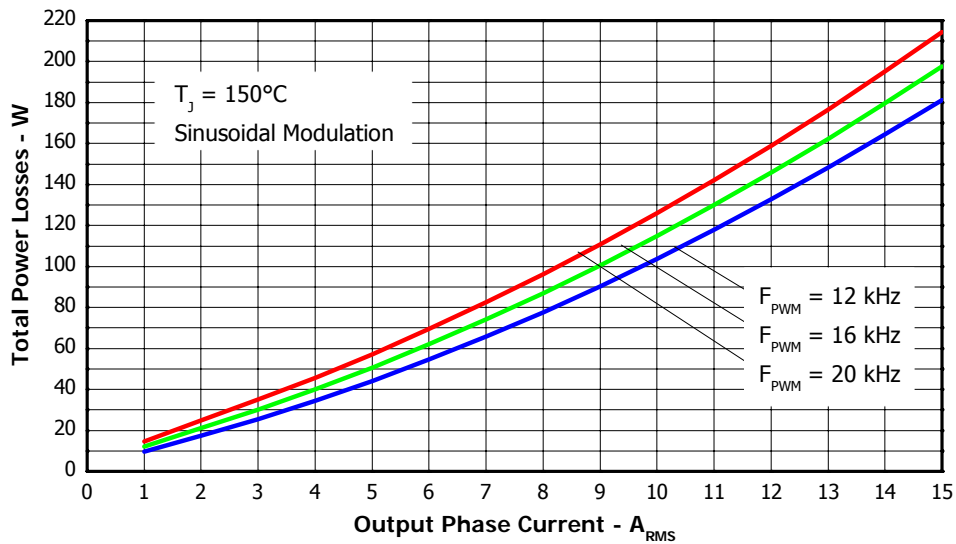

Figure 6. Total Power Losses vs. Output Phase Current, Sinusoidal modulation
 $V_{BUS}=400\text{V}$, $T_j=150^\circ\text{C}$, Modulation Depth=0.8, PF=0.6

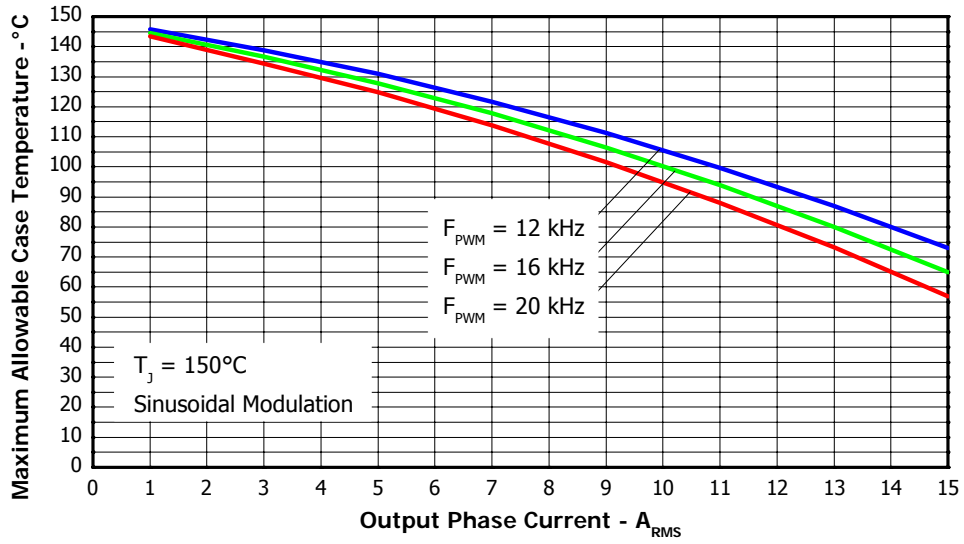

Figure 7. Maximum Allowable Case temperature vs. Output RMS Current per Phase

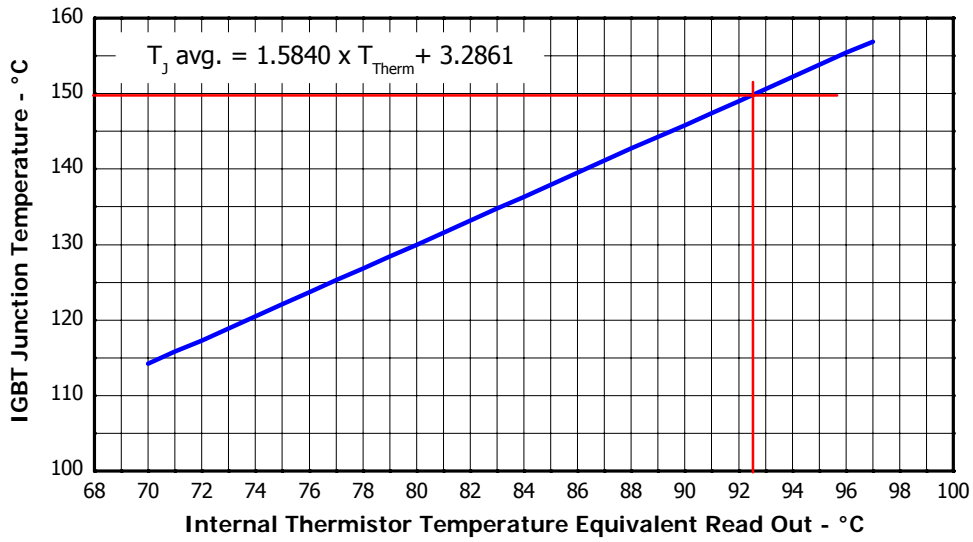

Figure 8. Estimated Maximum IGBT Junction Temperature vs. Thermistor Temperature

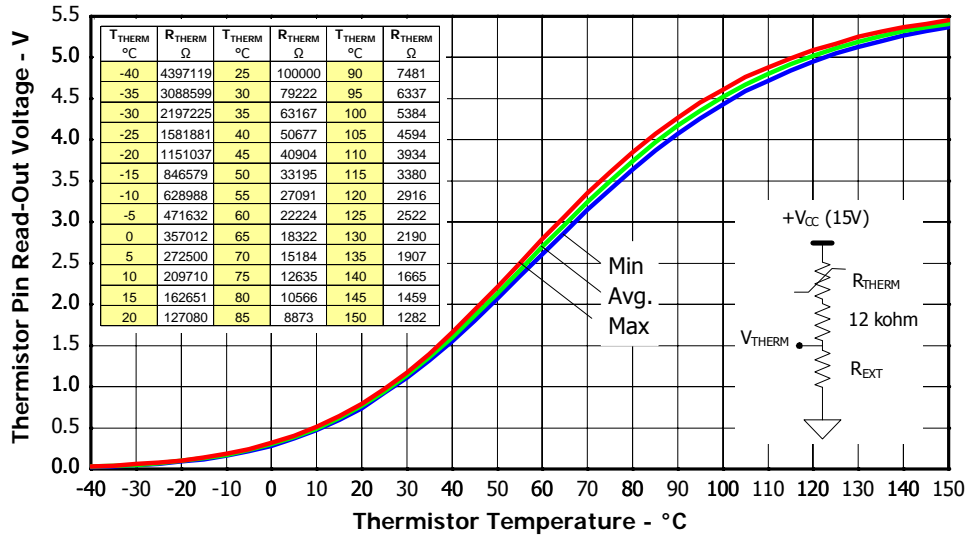

Figure 9. Thermistor Readout vs. Temperature (7.5kohm pull-up resistor, 5V) and Nominal Thermistor Resistance values vs. Temperature Table.

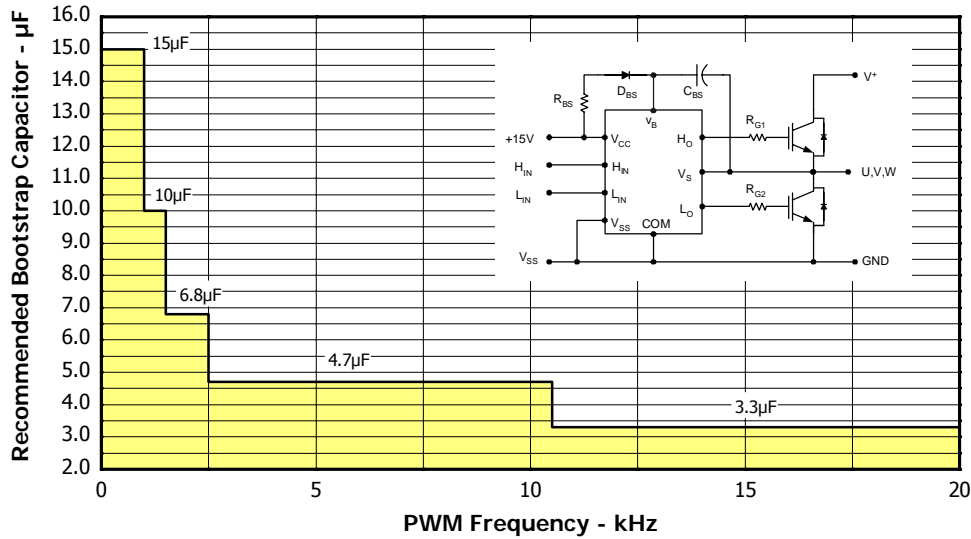

Figure 10. Recommended Bootstrap Capacitor Value vs. Switching Frequency

Figure 11. Switching Parameter Definitions

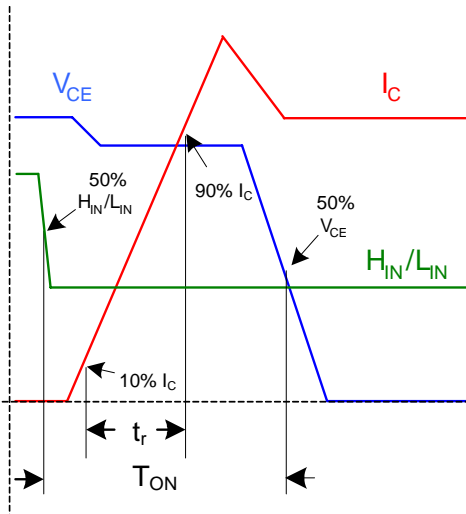

Figure 11a. Input to Output propagation turn-on delay time.

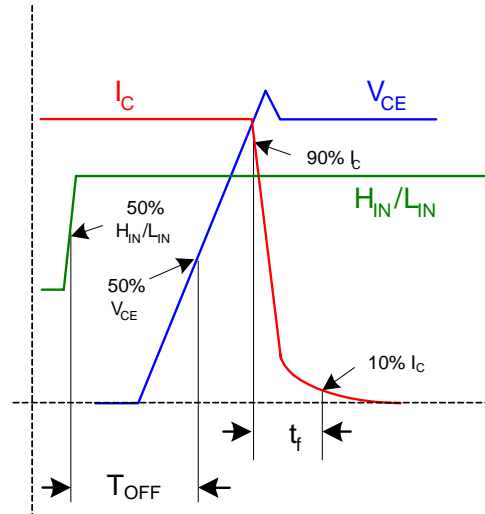

Figure 11b. Input to Output propagation turn-off delay time.

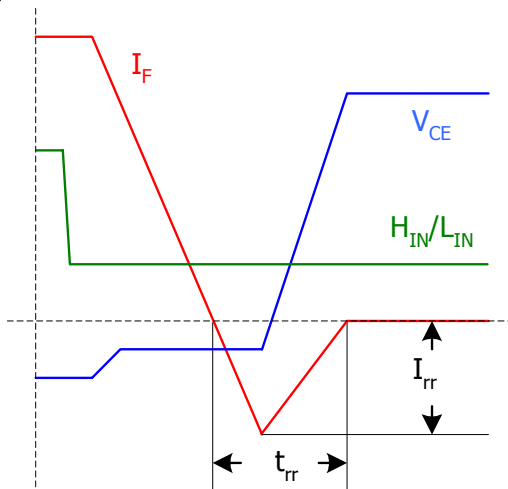

Figure 11c. Diode Reverse Recovery.

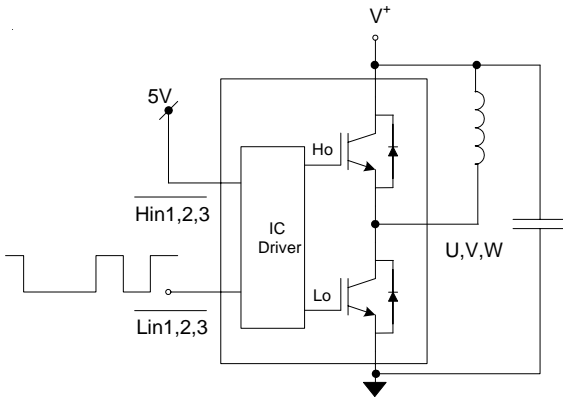

Figure CT1. Switching Loss Circuit

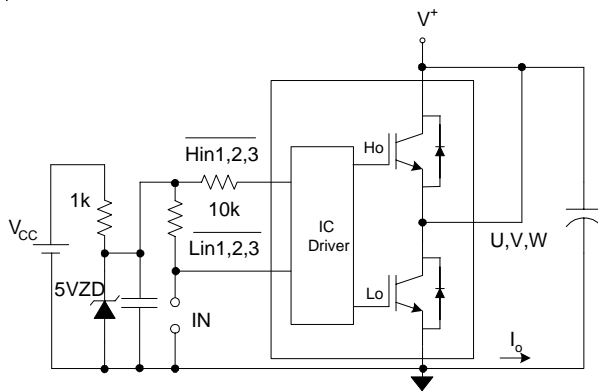

Figure CT2. S.C.SOA Circuit

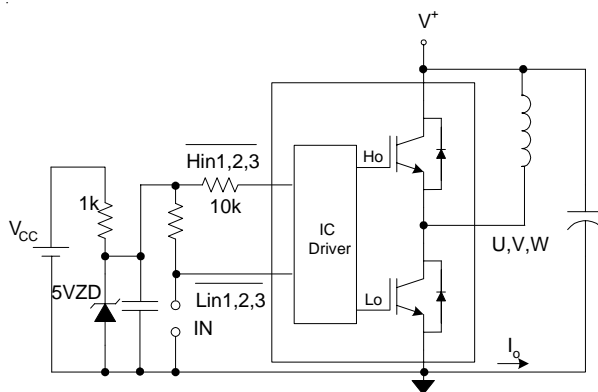
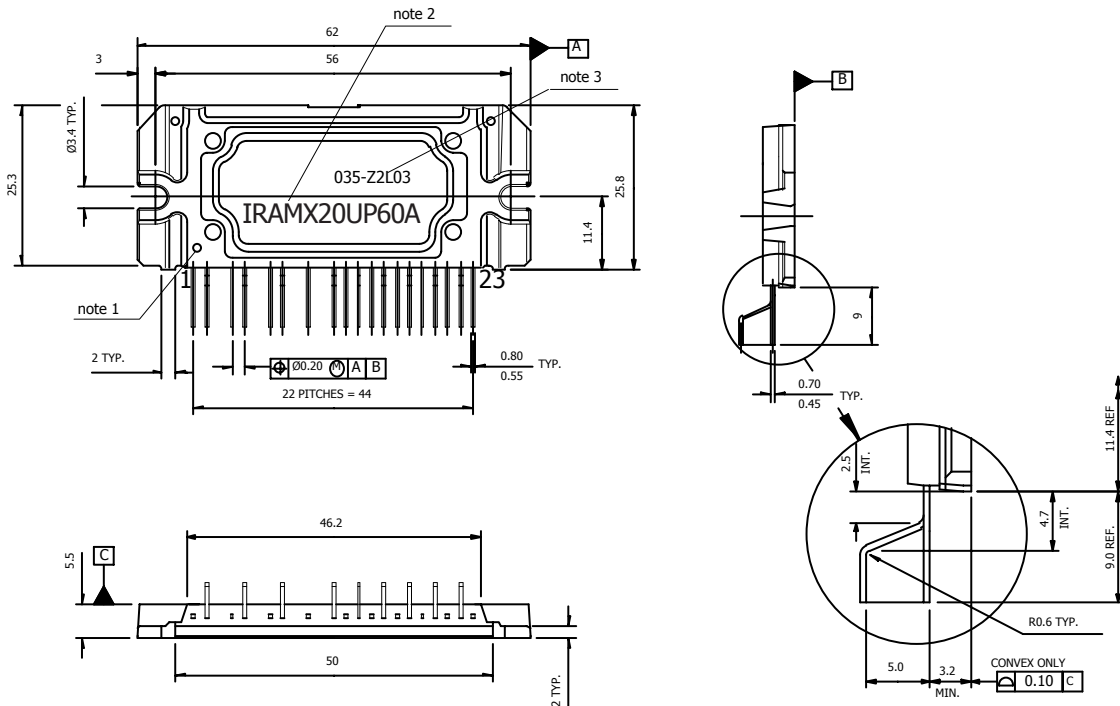

Figure CT3. R.B.SOA Circuit

IRAMX20UP60A



Package Outline IRAMX20UP60A



- Notes:
- Dimensions in mm
 - 1- Marking for pin 1 identification
 - 2- Product Part Number
 - 3- Lot and Date code marking
 - 4- Convex only 0.10mm typical.

For mounting instruction see AN-1049

Package Outline IRAMX20UP60A-2

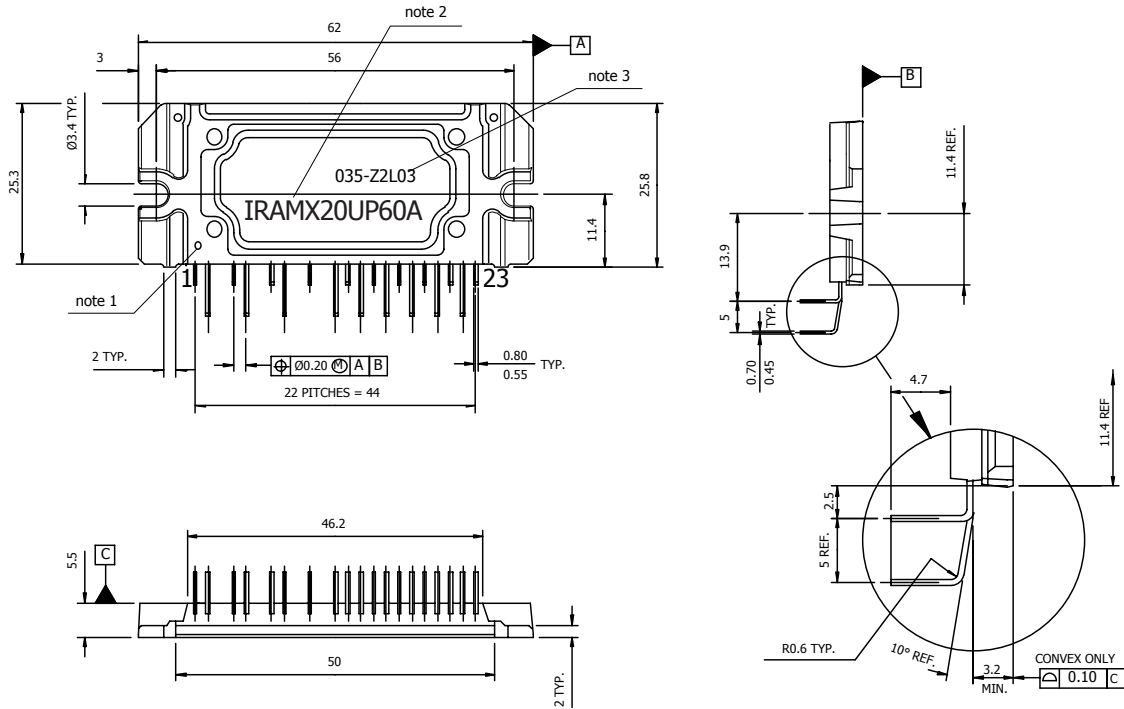

Notes:

Dimensions in mm

- 1- Marking for pin 1 identification
- 2- Product Part Number
- 3- Lot and Date code marking
- 4- Convex only 0.10mm typical.

For mounting instruction see AN-1049

Data and Specifications are subject to change without notice

IR WORLD HEADQUARTERS: 233 Kansas St., El Segundo, California 90245, USA Tel: (310) 252-7105
TAC Fax: (310) 252-7903

Visit us at www.irf.com for sales contact information

03/05