



# 21050 PCI-to-PCI Bridge

## Brief Datasheet

### Product Features

Intel's 21050 is a low-cost, high-performance bridge that expands the electrical capacity of PCI based systems.

- Complies fully with Revision 2.0 of the *PCI Local Bus Specification*
- Operates at a maximum frequency of 33 MHz
- Provides master latency timers and target wait timers that limit the amount of latency on either bus
- Provides concurrent primary and secondary bus operation
- Provides I/O transaction filtering through one programmable memory I/O address region
- Provides ISA-awareness for I/O transaction filtering
- Supports two 32-bit PCI buses
- Provides pins for buffer empty status and write-posting control
- Provides memory transaction filtering through two programmable memory address regions—one prefetchable and one non-prefetchable
- Provides dual-address transaction forwarding in the upstream direction
- Provides read prefetching for memory read transactions
- Supports seven secondary bus clock outputs
- Provides up to eight dwords (32 bytes) of write posting in both directions for memory write transactions
- Supports forwarding of video graphics adapter (VGA) memory and I/O addresses, and snooping of VGA palette I/O writes
- Supports perr and serr signals with error-checking functionality
- Propagates locks across the bridge
- Provides concurrent resource lock operation
- Provides programmable rotating arbiter supporting up to six secondary bus masters
  - Can be disabled through the s\_cfn\_1 input pin
- Conditionally forward the following transactions:
  - All memory read and write transactions in either direction
  - I/O read and write transactions in either direction
  - Configuration read and write transactions in the downstream direction
  - Configuration write transactions to special cycles in either direction



## Description

The 21050 allows motherboard designers to add more PCI devices or more PCI option card slots than a single PCI bus can support. Option card designers can use the 21050 to implement multiple-device PCI option cards. The 21050 can also isolate traffic between devices on one PCI bus from devices on the other PCI buses. This traffic isolation may increase system performance in applications such as multimedia.

An evaluation and development board is available for developers to develop software for the 21050 and evaluate its functionality.

## Applications

The 21050 makes it possible for the PCI bus to expand its electrical capacity by allowing additional PCI devices and PCI option card slots. Figure 1, the system card block diagram illustrates the use of two PCI-to-PCI bridges on a system board. Each 21050 added to the board creates a new PCI bus that provides additional support for the additional PCI slots or devices.

Information in this document is provided in connection with Intel products. No license, express or implied, by estoppel or otherwise, to any intellectual property rights is granted by this document. Except as provided in Intel's Terms and Conditions of Sale for such products, Intel assumes no liability whatsoever, and Intel disclaims any express or implied warranty, relating to sale and/or use of Intel products including liability or warranties relating to fitness for a particular purpose, merchantability, or infringement of any patent, copyright or other intellectual property right. Intel products are not intended for use in medical, life saving, or life sustaining applications.

Intel may make changes to specifications and product descriptions at any time, without notice.

Contact your local Intel sales office or your distributor to obtain the latest specifications and before placing your product order.

Copies of documents which have an ordering number and are referenced in this document, or other Intel literature may be obtained by calling 1-800-548-4725 or by visiting Intel's website at <http://www.intel.com>.

Copyright © Intel Corporation, 1998

\*Third-party brands and names are the property of their respective owners.

Figure 1. System Card Block Diagram

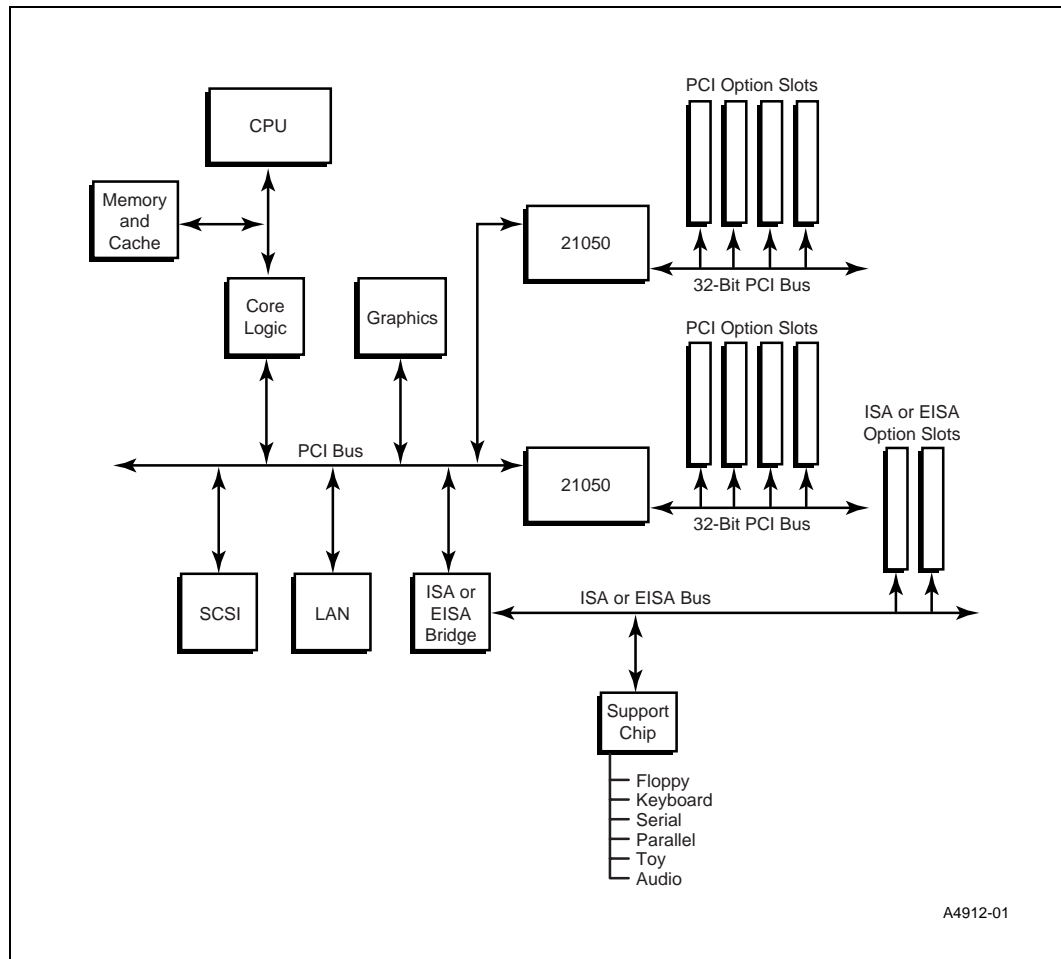

## Multidevice PCI Option Cards

The 21050 allows the PCI bus to support multiple components on option cards. Option cards are restricted to a single connection per PCI signal in the *PCI Local Bus Specification*. Figure 2, the 21050 with option cards diagram illustrates how the 21050 enables the design of a multicomponent option card.

Figure 2. 21050 with Option Cards

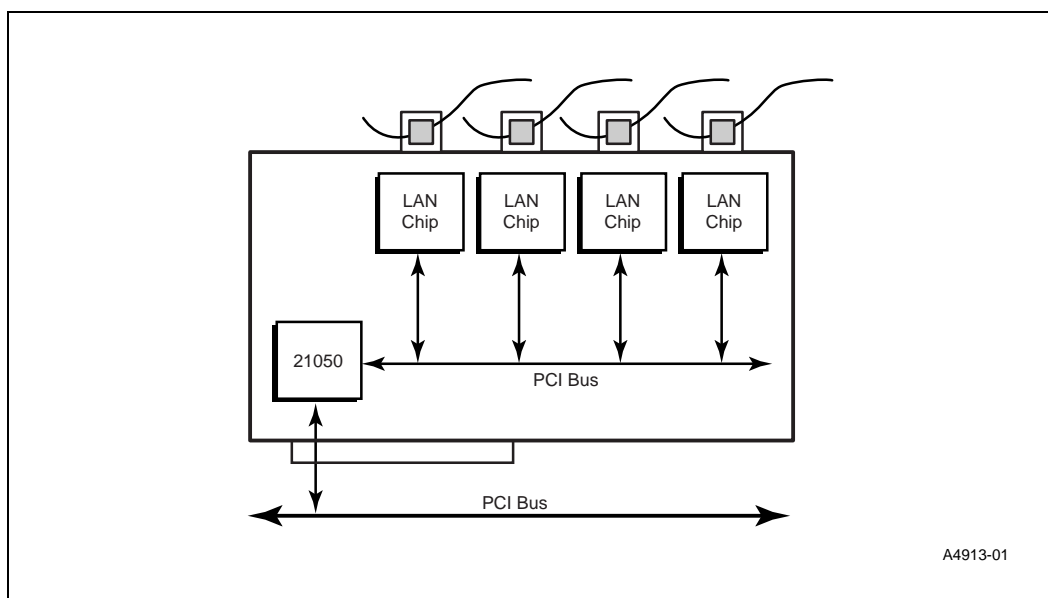

Characteristics	Specifications
Power supply	$V_{SS}$ 0.0 V, $V_{DD}$ 5 V $\pm$ 5%
Operating temperature	$T_j$ maximum = 100°C
Storage temperature range	-55°C to +125°C (-67°F to 257°F)
Power dissipation (typical)	1.7 W maximum
Package	208-pin PQFP



# Support, Products, and Documentation

If you need technical support, a *Product Catalog*, or help deciding which documentation best meets your needs, visit the Intel World Wide Web Internet site:

<http://www.intel.com>

Copies of documents that have an ordering number and are referenced in this document, or other Intel literature may be obtained by calling **1-800-332-2717** or by visiting Intel's website for developers at:

<http://developer.intel.com>

You can also contact the Intel Massachusetts Information Line or the Intel Massachusetts Customer Technology Center. Please use the following information lines for support:

<b>For documentation and general information:</b>	
Intel Massachusetts Information Line	
United States:	1-800-332-2717
Outside United States:	1-303-675-2148
Electronic mail address:	techdoc@intel.com

<b>For technical support:</b>	
Intel Massachusetts Customer Technology Center	
Phone (U.S. and international):	1-978-568-7474
Fax:	1-978-568-6698
Electronic mail address:	techsup@intel.com