

DIGITAL COMPASS SOLUTION

Features

- Fully Integrated Compass Module
- 2-Axis Magnetic Sensors with Electronics
- Miniature (6.5 by 6.5 by 1.4mm) 24-Pin LCC Package
- 2.7 to 5.2 volt Supply Range
- Accurate Compassing Capability
- I²C Digital Interface
- User Selectable Slave Address

Product Description

The Honeywell HMC6352 2-Axis Digital Integrated Compass Solution combines a two-axis MR magnetic field sensor design with the required analog and digital support circuits for heading computation.

By combining the sensor elements and all the processing electronics into a 6.5mm square LCC package, designers will have the simplest solution to integrate low cost and space efficient electronic compasses for wireless phones, consumer electronics, vehicle compassing, and antenna positioning.

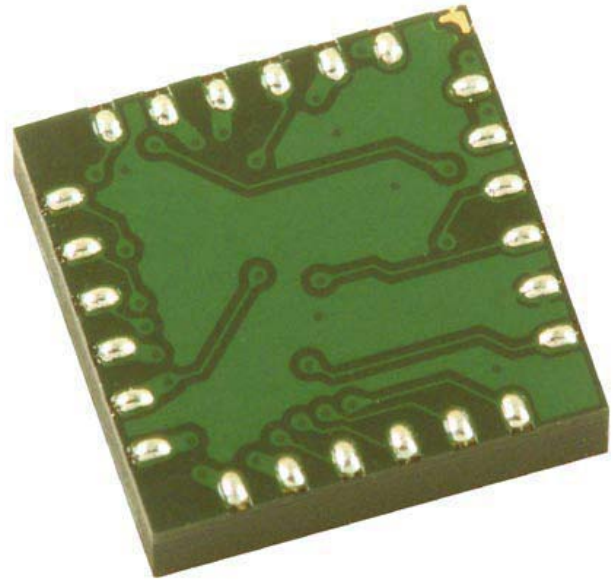

BOTTOM VIEW

DIAGRAMS

PINOUT
TOP VIEW

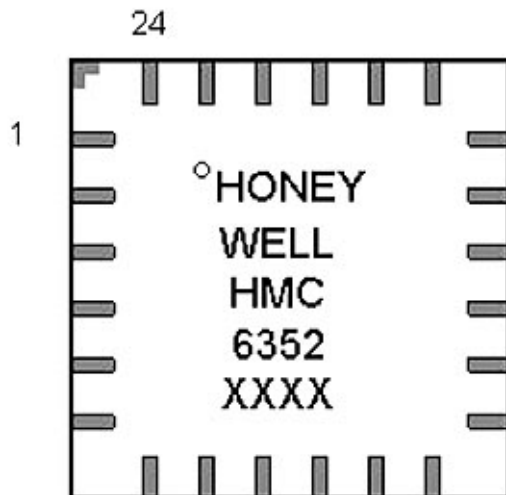

BLOCK DIAGRAM

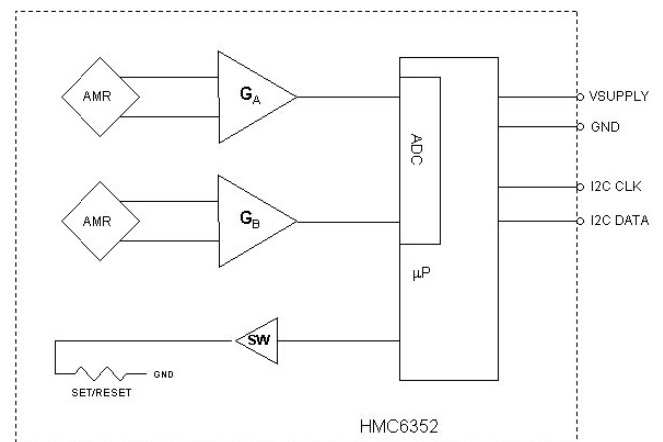

HMC6352 SPECIFICATIONS

Characteristics	Conditions ⁽¹⁾	Min	Typ	Max	Units
Supply Voltage	Vsupply to GND	2.7	3.0	5.2	Volts
Supply Current	Vsupply to GND Steady State (Vsupply = 3.0V) Steady State (Vsupply = 5.0V) Dynamic Peaks		1 2	10	mA mA mA
Field Range ⁽²⁾	Total applied field	0.10	-	0.75	gauss
Heading Accuracy	HMC6352E HMC6352		3 9		degRMS
Heading Resolution			0.3		deg
Heading Repeatability			TBD		deg
Disturbing Field	Sensitivity starts to degrade. Enable set/reset function to restore sensitivity.	20			gauss
Max. Exposed Field	No permanent damage and set/reset function restores performance.			10000	gauss
Operating Temperature	Ambient	-20		70	°C
Storage Temperature	Ambient	-40		125	°C
Output	Digital – I ² C Interface				
Size	6.5 x 6.5 x 1.4				mm
Weight			TBD		grams

(1) Tested at 25°C except stated otherwise.

(2) Field upper limit can be extended by using external resistors across CA1/CA2 and CB1/CB2.

Pin Configuration/Package Dimensions

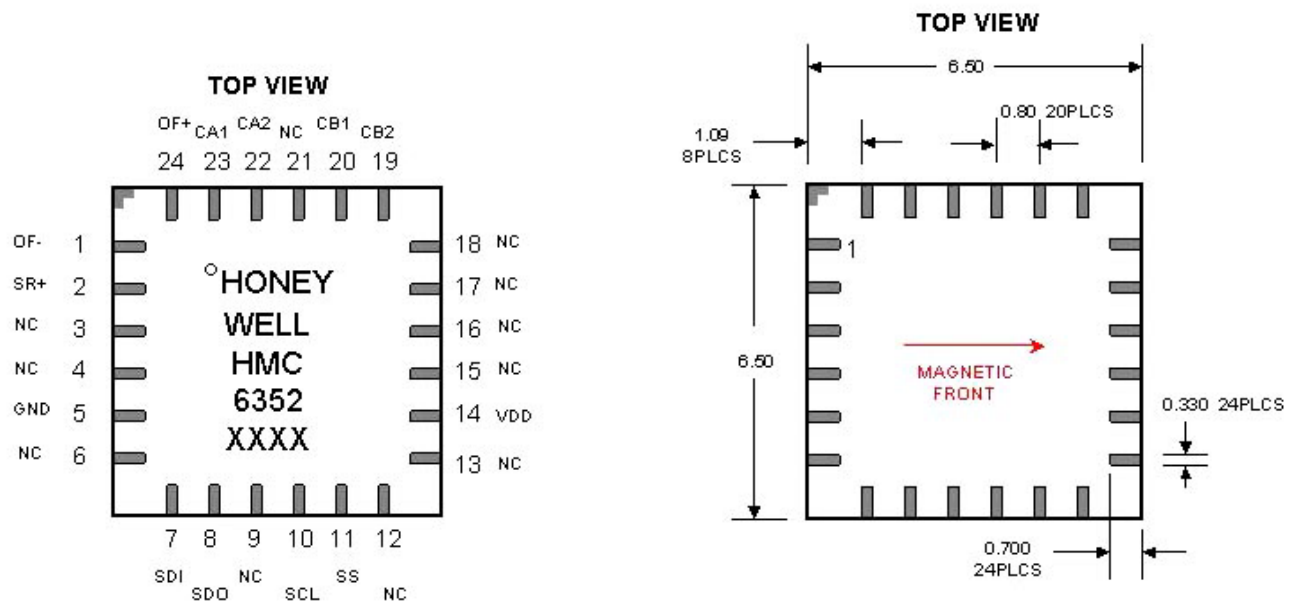

Pin Descriptions

HMC6352

Pin	Name	Description
1	OF-	No User Connection (Offset Strap Negative)
2	SR+	No User Connection (Set/Reset Strap Positive)
3	NC	No User Connection
4	NC	No User Connection
5	GND	Supply/System Ground
6	NC	No User Connection
7	SDI	I2C Data Output (SPI Data In)
8	SDO	No User Connection (SPI Data Out)
9	PGM	No User Connection (Program Enable)
10	SCL	I2C Clock (SPI Clock)
11	SS	No User Connection (Slave Select)
12	NC	No User Connection
13	NC	No User Connection
14	VDD	Supply Voltage Positive Input (+2.7VDC to +5.0VDC)
15	NC	No User Connection
16	NC	No User Connection
17	NC	No User Connection
18	NC	No User Connection
19	CB2	Amplifier B Filter Capacitor Connection
20	CB1	Amplifier B Filter Capacitor Connection
21	NC	No User Connection
22	CA2	Amplifier A Filter Capacitor Connection
23	CA1	Amplifier A Filter Capacitor Connection
24	OF+	No User Connection (Offset Strap Positive)

Application Notes

The HMC6352 Integrated Compass Sensor circuit is composed of two magneto-resistive (MR) sensors with orthogonal orientation for sensing the horizontal components of the earth's magnetic field (0 to 630 milli-gauss), plus two amplifiers, a set/reset drive circuit, and a microprocessor (μP). Best accuracy is obtained in clean magnetic environments (free air) and held level, or perpendicular to the gravitational direction. At worst case, each degree of tilt from a level orientation could add two degrees of compass heading error. Magnetic errors can be introduced if operated near strong magnetic sources such as microphone or speaker magnets, transformers in test equipment, and CRT deflection yokes in video displays/monitors. These magnetic errors can typically be reduced or eliminated by performing the calibration routine.

When locating the HMC6352 in dense printed circuit board designs, take precautions in location of this magnetic field sensing device for soft-iron effects that bend the earth's magnetic field. These soft-iron effects are from ferrous materials without residual magnetization and tend to be items like nickel-plating on SMT component contacts and RFI/EMI shielding materials. The amount of stand-off of the HMC6352 from these soft-irons is heuristic and dependant on the amount of material, material shape, and proximity.

A user calibration mode is available in the HMC6352 to diminish hard-iron effects of the end-user's (customer's) location of the product. Hard-iron effects come from nearby ferrous materials with residual magnetism that buck or boost the intensity of the earth's magnetic field, leading to heading errors. Such hard-iron effects come from vehicle chassis, speaker magnets, and high current conductors or circuit traces.

I²C Communication Protocol

The HMC6352 communicates via a two-wire I²C bus system as a slave device. The HMC6352 uses a layered protocol with the interface protocol defined by the I²C bus specification, and the lower command protocol defined by Solid State Electronics Center • www.magneticsensors.com • (800) 323-8295 • Page 3

Honeywell. The data rate is the standard-mode 100kbps rate as defined in the I²C Bus Specification 2.1. The bus bit format is an 8-bit Data/Address send and a 1-bit acknowledge bit. The format of the data bytes (payload) shall be case sensitive ASCII characters or binary data to the HMC6352 slave, and binary data returned. Negative binary values will be in two's complement form. The default (factory) HMC6352 slave address is 42(hex) for commands, or 43(hex) for response data bytes; and is a 7-bit address with the 0 bit (LSB) being the Read/Write selection.

The HMC6352 Serial Clock (SCL) and Serial Data (SDA) lines do not have internal pull-up resistors, and require resistive pull-ups (Rp) between the master device and the HMC6352. Pull-up resistance values of about 10k ohms are recommended with a nominal 3.0-volt supply voltage. Other values may be used as defined in the I²C Bus Specification 2.1.

Command Protocol

The command protocol defines the content of the data (payload) bytes of I²C protocol sent by the master device (host microprocessor), and the slave device (HMC6352).

After the master device sends the 7-bit slave address, the 1-bit Read/Write, and gets the 1-bit slave device acknowledge bit returned; the next one to three sent data bytes are defined as the input command and argument bytes. To conserve data traffic, all response data (Reads) will be context sensitive to the last command (Write) sent. All commands shall have the address byte least significant bit cleared (factory default 42(hex)). These command then follow with the ASCII command byte and command specific binary formatted argument bytes in the general form of:

(Command ASCII Byte) (Argument Binary MS Byte) (Argument Binary LS Byte)

The slave (HMC6352) shall provide the acknowledge bits between each data byte per the I²C protocol. Response byte reads are done by sending the address byte (factory default 43(hex)) with the least significant bit set, and then clocking back one or two response bytes, last command dependant. For example, an "A" command prompts the HMC6352 to make a sensor measurement and to route all reads for a two byte compass heading or magnetometer data response. Then all successive reads shall clock out two response bytes after sending the slave address byte. Table 1 shows the HMC6352 command and response data flow.

Table 1 – Interface Commands/Responses

Command Byte (ASCII)	Argument 1 Byte (Binary)	Argument 2 Byte (Binary)	Response 1 Byte (Binary)	Response 2 Byte (Binary)	Description
W	Address	Data			Write to EEPROM
R	Address		Data		Read from EEPROM
G	Address	Data			Write to RAM Register
g	Address		Data		Read from RAM Register
S					Enter Sleep Mode (Sleep)
W					Exit Sleep Mode (Wakeup)
O					Update Bridge Offsets (S/R Now)
C					Enter User Calibration Mode
E					Exit User Calibration Mode
L					Save Op Mode to EEPROM
A			MSB Data	LSB Data	Get Data. Calculate New Heading

Operational Modes

The HMC6352 has three operational modes plus the ability to enter/exit the non-operational (sleep) mode by command. Sleep mode sends the internal microprocessor into clock shutdown to save power, and can be brought back by the "W" command (wake). The "S" command returns the processor to sleep mode. The three operational modes are defined by two bits in the internal HMC6352 operation mode register. If the master device sends the "L" command, the current operational mode byte in the RAM register is loaded into the internal EEPROM register and becomes the default operational mode on the next power-up. The operational mode selection byte RAM register address is 74(hex).

Standby Mode: (Operational Mode 0) This is the factory default mode. The HMC6352 waits for master device commands or change in operational mode. Receiving an “A” command (get data) will make the HMC6352 perform a measurement of sensors (magnetometers), compute the compensated magnetometer and heading data, and wait for the next read or command. No new measurements are done until another “A” command is sent.

Query Mode: (Operational Mode 1) In this mode the internal processor waits for “A” commands (get data), makes the measurements and computations, and waits for the next read command to output the data. After each read command, the HMC6352 automatically performs another get data routine and updates the data registers. This mode is designed to get data on demand without repeating “A” commands, and with the master device controlling the timing and data throughput.

Continuous Mode: (Operational Mode 2) The HMC6352 performs continuous sensor measurements and data computations at selectable rates of 1Hz, 5Hz, 10Hz, or 20Hz, and updates the output data bytes. Subsequent “A” commands are un-necessary unless re-synchronization to the command is desired. Data reads automatically get the most recent updates.

The continuous mode measurement rate is selected by two bits in the operational mode selection byte, along with the mode selection and the periodic Set/Reset bit. The periodic Set/Reset function performs a re-alignment of the sensors magnetic domains in case of sensor perming (magnetic upset event), operating temperature shifts, and normal thermal agitation of the domains. Exposure of the HMC6352 to magnetic fields above 20 gauss (disturbing field threshold) leads to possible measurement inaccuracy or “stuck” sensor readings until the set/reset function is performed. With the periodic Set/Reset bit set, the set/reset function occurs every few minutes.

Operational Mode Byte Syntax

As described above, the HMC6352 operation mode, measurement rate, and periodic set/reset are selected and stored both in a processor RAM register and in EEPROM. Upon power-up the EEPROM will transfer the saved operational mode byte into register address 74(hex). The following is the byte format:

Bit 7 = 0

Bits 6 and 5 (Continuous Mode Measurement Rate)

Bit 6	Bit 5	Description
0	0	1 Hz Measurement Rate
0	1	5 Hz Measurement Rate
1	0	10 Hz Measurement Rate
1	1	20 Hz Measurement Rate

Bit 4 (Periodic Set/Reset), 0 = Off, 1 = On

Bit 3 = 0

Bit 2 = 0

Bits 1 and 0 (Operational Mode Value)

Bit 1	Bit 0	Description
0	0	Standby Mode
0	1	Query Mode
1	0	Continuous Mode
1	1	Not Allowed

The total bit format for the Operational Mode Byte is shown below:

Bit 7 (MSB)	Bit 6	Bit 5	Bit 4	Bit 3	Bit 2	Bit 1	Bit 0 (LSB)
0	M. Rate_H	M. Rate_L	Per. S/R	0	0	Op Mode_H	Op Mode_L

Output Data

The read response bytes after an “A” command, will cause the HMC6352 will return two bytes with binary formatted data. Either heading or magnetometer data can be retrieved depending on the output data selection byte value. Negative signed magnetometer data will be returned in two’s complement form. This selection byte is located in RAM register location 4E(hex) and defaults to value zero (heading) at power up.

The following is the byte format:

Bits 7 through 3 = 0

Bits 0, 1, 2 (Output Mode Value)

Bit 2	Bit 1	Bit 0	Description
0	0	0	Heading Mode
0	0	1	Raw Magnetometer X Mode
0	1	0	Raw Magnetometer Y Mode
0	1	1	Magnetometer X Mode
1	0	0	Magnetometer Y Mode

The total bit format for the Output Mode Byte is shown below:

Bit 7 (MSB)	Bit 6	Bit 5	Bit 4	Bit 3	Bit 2	Bit 1	Bit 0 (LSB)
0	0	0	0	0	Mode	Mode	Mode

Heading Mode: The heading output data will be the value in tenths of degrees from zero to 3599 and provided in binary format over the two bytes.

Raw Magnetometer Modes: These X and Y raw magnetometer data readings are the internal sensor values measured at the output of amplifiers A and B respectively and are 10-bit 2’s complement binary ADC counts of the analog voltages at pins CA1 and CB1. The leading 6-bits on the MSB are zero filled or complemented for negative values. The zero count value will be about half of the supply voltage. If measurement averaging is implemented, the most significant bits may contain values of the summed readings.

Magnetometer Modes: These X and Y magnetometer data readings are the raw magnetometer readings plus offset and scaling factors applied. The data format is the same as the raw magnetometer data. These compensated data values come from the calibration routine factors plus additional offset factors provided by the set/reset routine.

User Calibration

The HMC6352 provides a user calibration routine with the “C” command permitting entry into the calibration mode and the “E” command to exit the calibration mode. Once in calibration mode, the user is requested to rotate the compass at least one full rotation while the HMC6352 collects several readings per second at various headings with the emphasis on rotation smoothness to gather uniformly spaced readings. Optimally two rotations over 20 seconds duration would provide an accurate calibration. The calibration time window is recommended to be from 6 seconds up to 3 minutes depending on the end user’s platform.

The calibration routine collects these readings to correct for hard-iron distortions of the earth’s magnetic field. These hard-iron effects are due to magnetized materials nearby the HMC6352 part that in a fixed position with respect to the end user platform. An example would be the magnetized chassis or engine block of a vehicle in which the compass is mounted onto. Upon exiting the calibration mode, the resulting magnetometer offsets and scaling factors are updated

Non-Volatile Memory

The HMC6352 contains non-volatile memory capability in the form of EEPROM that retains key operational parameters and settings for electronic compassing. Table 2 shows the memory location addresses and byte descriptions.

Table 2 – EEPROM Contents

Address (hex)	Byte Description
00	I2C Slave Address
01	Magnetometer X Offset MSB
02	Magnetometer X Offset LSB
03	Magnetometer Y Offset MSB
04	Magnetometer Y Offset LSB
05	Time Delay (0 to 255 milli-seconds)
06	Number of Summed Measurements (1 to 16)
07	Software Version Number

I²C Slave Address

The I²C slave address byte consists of the 7 most significant bits with the least significant bit zero filled. As described earlier, the default (factory) value is 42(hex) and the legal I²C bounded values are between 10(hex) and F6(hex).

Magnetometer Offsets

The Magnetometer Offset bytes are the values stored after the completion of the last factory or user calibration routine. Additional value changes are possible, but will be overwritten when the next calibration routine is completed. Note that these offset values are added to the sensor offset values computed by the set/reset routine to convert the raw magnetometer data to the compensated magnetometer data.

Time Delay

The EEPROM time delay byte is the binary value of the number of milliseconds from the time a measurement request was commanded and the time the actual measurements are made. The default value is 01(hex) for no delay. Extra measurement delays may be desired to allow for amplifier stabilization from immediate HMC6352 power-up or for external filter capacitor selection that limits the bandwidth and time response of the amplifier stages.

Measurement Summing

This EEPROM summed measurement byte permits designers/users to back average or data smooth the output data (heading, magnetometer values) to reduce the amount of jitter in the data presentation. The default value is 04(hex) which is the last five measurements summed. A value of 00(hex) would be no summing. Up to 16 sets of magnetometer data may be selected for averaging.

Software Version

This EEPROM software version number byte contains the binary value of the programmed software. Values of 01(hex) and beyond are considered production software.

REFERENCE DESIGN

The schematic diagram in Figure 1 shows the basic HMC6352 application circuit with a minimum of external components.

From Figure 1, the host microprocessor (μ P) controls the HMC6352 via I²C serial data interface lines for data (SDA) and clock (SCL). Two external 10k-ohm pull-up resistors to the nominal +3 volt DC supply create normally high logic states when the interface lines are not in use. The host initiates use of the interface by creating the 100kHz clock and

pulling low the data line to indicate the start condition. The data line logic state transitions are only allowed during the clock low states and require the data line to be stable in the high states, with the exception of the start and stop conditions.

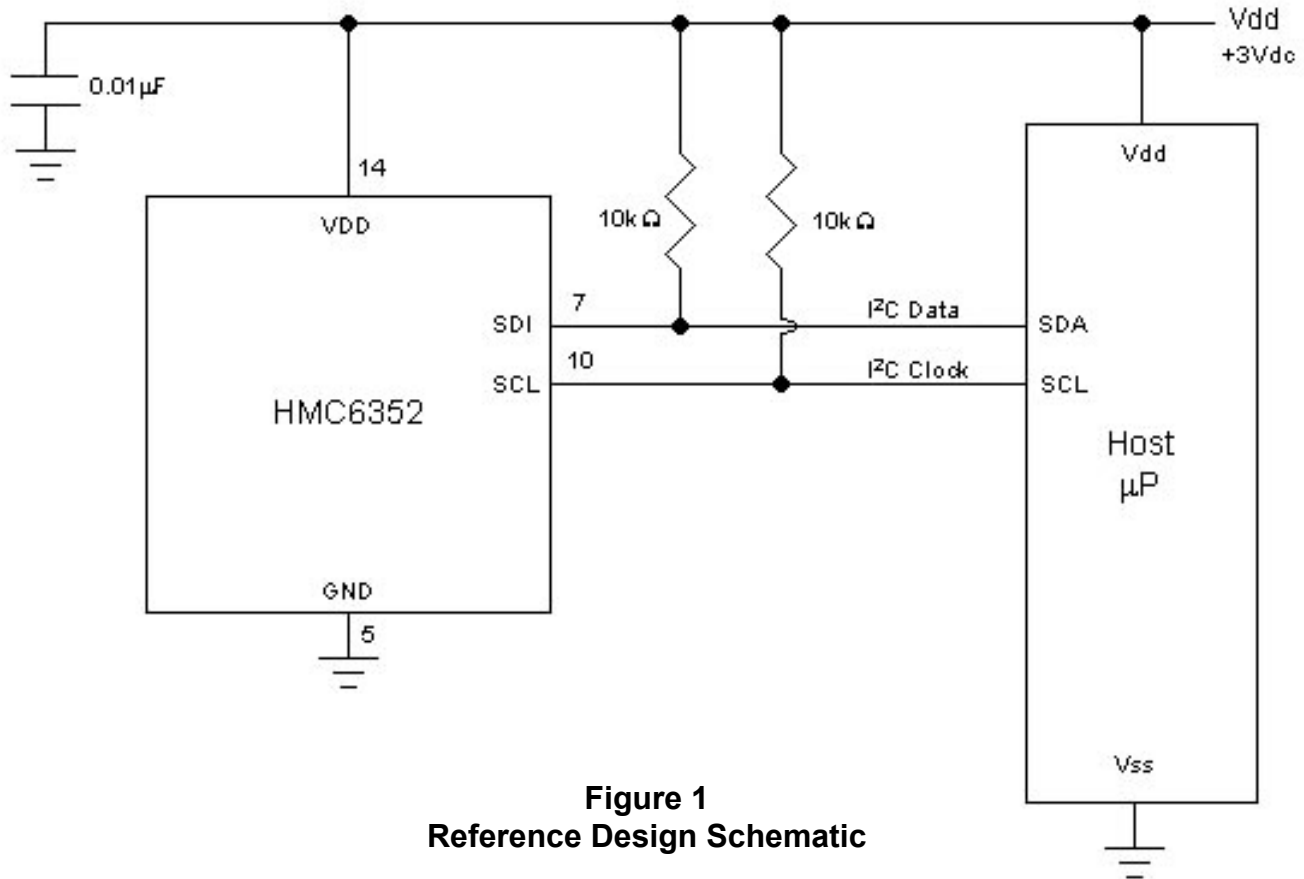

Figure 1
Reference Design Schematic

The 0.01μF supply decoupling capacitor in this reference can be omitted if another supply filter capacitor is already included in the overall circuit design. If the supply traces extend beyond a couple inches to the HMC6352, it is advisable to add a local supply decoupling capacitor near the HMC6352 to retain optimum circuit stability.

Additional masters and slaves can be added to the I²C bus traces without interface trouble to the HMC6352. There are no periodic maintenance commands required, and even HMC6352 sleep mode or power shutdown can be accomplished without harm to the data or clock lines.

Amplifier Filter Connections

The HMC6352 design has provisions for the feedback loop of each amplifier stage to be accessible via the CA1, CA2, CB1, and CB2 pin contacts. Across the contacts and internal to the HMC6352 is the amplifier section plus a 120k-ohm feedback resistance to set the voltage gain. By placing small value ceramic capacitors across CA1 to CA2 (or CB1 to CB2), the designer can set the -3dB bandwidth of the amplified magnetometer signals to drop spurious magnetic interference in the system. For example a 120 pico-Farad capacitor (Cext) in the amplifier feedback loop would limit the bandwidth to about 1kHz. Be aware that larger values of capacitance begin to slow the amplifier response to where the measurement delay time EEPROM byte may have to be increased in value to let the signal settle before making a measurement. Figure 2 shows the partial schematic of the amplifier feedback loop.

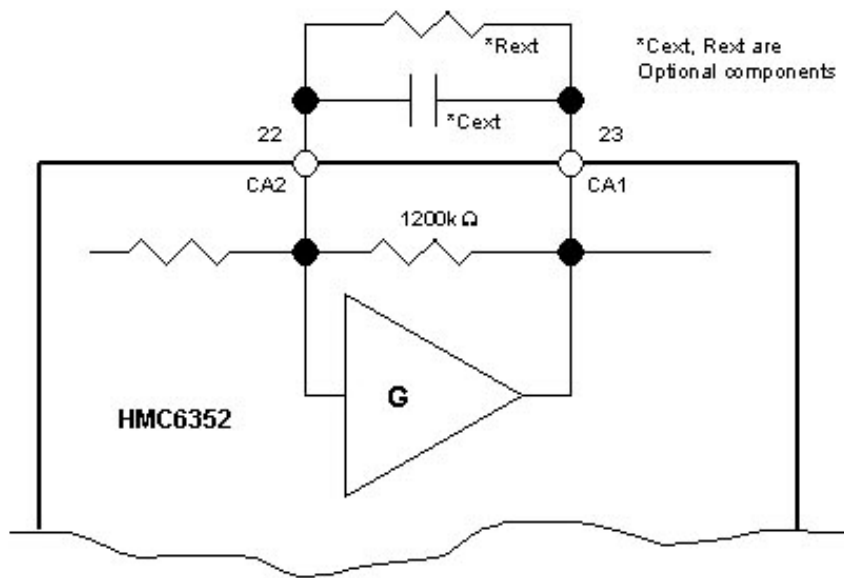

Figure 2
Amplifier Filter Connections

An optional gain reducing resistor (Rext) could also place across the feedback loop of the amplifier stages. With the amplifier set with the internal 1200 k-ohm feedback for ±750 milli-gauss maximum magnetic field flux density, a second 1200k-ohm external resistor would halve the gain and permit ±1.5 gauss capability if desired. Gain can be reduced for up to ±6 gauss capability for magnetometry-only applications or compassing with significant magnetic stray fields nearby.

ORDERING INFORMATION

Ordering Number	Product
HMC6352I	Digital Compass Solution, I2C
HMC6352E	Digital Compass Solution, I2C, Enhanced

Honeywell reserves the right to make changes to improve reliability, function or design. Honeywell does not assume any liability arising out of the application or use of any product or circuit described herein; neither does it convey any license under its patent rights nor the rights of others.

U.S. Patents 4,441,072 4,533,872 4,569,742 4,681,812 4,847,584 6,529,114 and patents pending apply to the technology described herein.

900307 05-03 Rev –