

# GR881

## DESCRIPTION

The GR881 is a 8192 word by 8 bits (8K x 8) non-volatile CMOS Static Ram, fabricated from advanced silicon gate CMOS technology and a high reliability lithium power cell. The pin-out of the GR881 conforms to the JEDEC standards and is fully compatible with normal static RAM. The power down circuit is fully automatic and is referenced at 4.5 volts. At this point the GR881 is write protected by an internal inhibit function for Data Protection and the memory contents are retained by the lithium power source. Power down is very fast, this being essential for data integrity, taking a maximum of 15  $\mu$ S (15 microseconds) to power down from 5 volts to 0 volts. This is much faster than system power failure conditions. Therefore there are no special conditions required when installing the GR881. The GR881 can, without external power, retain data almost indefinitely. The limiting factor will be the shelf life of the lithium cell, which is typically ten years. It is possible that this figure may be extended in view of the extremely light duty imposed upon the cell.

## TECHNICAL DATA

ABSOLUTE MAXIMUM RATINGS			
Symbol	Min	Max	Units
Vdd	-0.3	7.0	Volts
V <sub>io</sub>	-0.3	Vdd + 0.3	Volts
Temp	-20	+70	deg. C

OPERATING MODE					
CE	OE	WR	MODE	OUTPUT	I <sub>dd</sub>
H	X	X	Unsel.	Hi-Z	Standby
L	H	H	Unsel.	Hi-Z	Active
L	L	H	Read	Dout	Active
L	X	L	Write	Din	Active

PIN CONNECTIONS			PIN DESIGNATIONS	
NC	1	28	Vdd	
A12	2	27	WR	
A7	3	26	CE <sub>2</sub>	
A6	4	25	A8	
A5	5	24	A9	
A4	6	23	A11	
A3	7	22	OE	
A2	8	21	A10	
A1	9	20	CE <sub>1</sub>	
A0	10	19	D7	
D0	11	18	D6	
D1	12	17	D5	
D2	13	16	D4	
GND	14	15	D3	

OPERATING CONDITIONS				
Symbol	Min	Typ	Max	Unit
Vdd	4.75	5.0	5.5	Volts
V <sub>in</sub> (*)	2.2		Vdd+0.3	Volts
V <sub>in</sub> (0)	-0.3		0.8	Volts
I <sub>in</sub> (any other pin)	-1.0		+1.0	$\mu$ A
V <sub>out</sub> (1) (I <sub>out</sub> = -1mA)	2.4			Volts
V <sub>out</sub> (0) (I <sub>out</sub> = +2mA)			0.4	Volts
I <sub>dd</sub> (Active)		30		mA
I <sub>dd</sub> (Deselected)		1.0		mA
T <sub>cycle</sub>			100	nS
C <sub>in</sub> (any pin)		10		pF

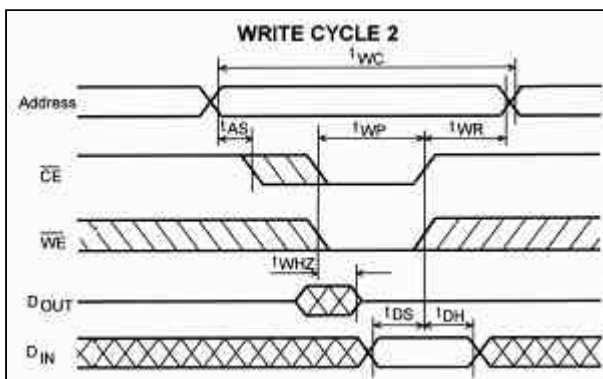
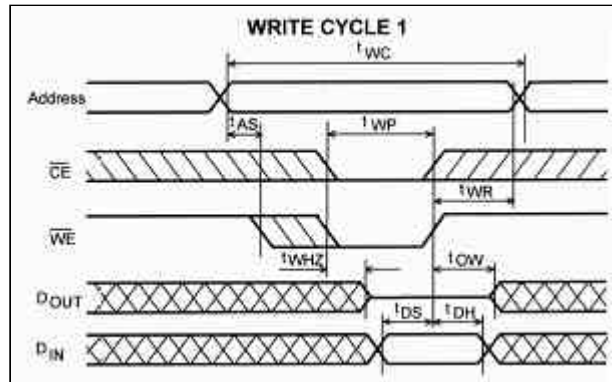
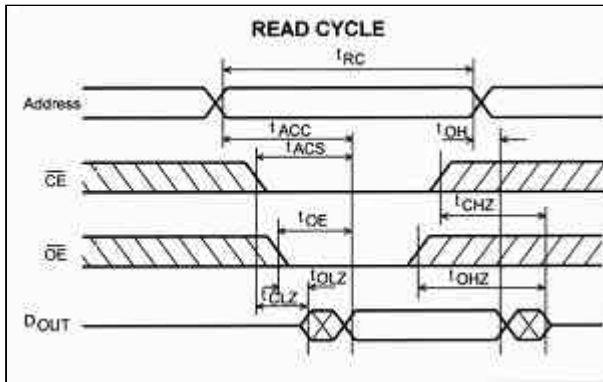

DATA RETENTION OPERATING CONDITIONS					
Symbol	Parameter	Min	Typ	Max	Units
Vdd	Operating supply voltage	4.75	5.0	5.50	Volts
VTH	Data retention voltage		4.5		Volts
t <sub>F</sub>	Vdd slew to 0V	15			$\mu$ S

t <sub>R</sub>	V <sub>dd</sub> slew 0V to 5.0V	15	μS
t <sub>REC</sub>	CE to O/P valid from power up	15	μS
t <sub>DR</sub>	Data retention time	10	Years
t <sub>PD</sub>	CE at Vin(1) before power down	0	μS

TIMING (nS-nano seconds)			
Read Cycle			
100nS			
Symbol	Parameter	Min	Max
t <sub>RC</sub>	Read cycle time	100	
t <sub>ACC</sub>	Access time		100
t <sub>ACS</sub>	CE to output valid		100
t <sub>OE</sub>	OE to output valid		40
t <sub>CLZ</sub>	CE to output active	10	
t <sub>OLZ</sub>	OE to output active	5	
t <sub>OH</sub>	Output hold time	10	
t <sub>CHZ</sub>	CE to output disable		30
t <sub>OHZ</sub>	OE to output disable		20
Write Cycle			
100nS			
Symbol	Parameter	Min	Max
t <sub>WC</sub>	Write cycle time	100	
t <sub>WP</sub>	Write pulse width	60	
t <sub>AS</sub>	Address setup time	0	
t <sub>WR</sub>	Write recovery time	0	
t <sub>WHZ</sub>	WR to output disable		30
t <sub>OW</sub>	Output active from WR	10	
t <sub>DS</sub>	Data setup time	40	
t <sub>DH</sub>	Data HOLD TIME	0	

Notes

1. WE must be high during address transitions.
2. A Write occurs during the overlap of active CE and a low WE.
3. CE = CE1 and CE2.
4. WE is high for a read cycle.

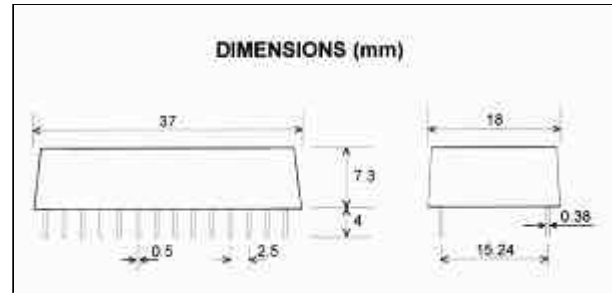

## APPLICATION

When powered down, the GR881 is transportable and data can be moved from system to system, this makes it ideal for programme development, data collection in data loggers, programme changes in process control, automation and robotics and user definable lookup tables, etc.

Additional information available through our technical services department.