



I. General Description

The EM78862 is an 8-bit RISC type microprocessor with low power , high speed CMOS technology . Integrated onto a single chip are on_chip watchdog (WDT) , RAM , ROM , programmable real time clock /counter , internal interrupt , power down mode , LCD driver and tri-state I/O . The EM78862 provides a single chip solution to design a DATA-BANK of message display .

II. Feature

CPU

- Operating voltage range : **2.5V ~ 5.5V**
- 16K× 13 on chip ROM
- 2.2K× 8 on chip RAM
- Up to 29 bi-directional tri-state I/O ports
- 8 level stack for subroutine nesting
- 8-bit real time clock/counter (TCC)
- Two sets of 8 bit counters can be interrupt sources
- Programmable free running on chip watchdog timer
- Four modes (internal clock 3.579MHz)
 1. Sleep mode : CPU and 3.579MHz clock turn off, 32.768KHz clock turn off
 2. Idle mode : CPU and 3.579MHz clock turn off, 32.768KHz clock turn on
 3. Green mode : 3.579MHz clock turn off, CPU and 32.768KHz clock turn on
 4. Normal mode : 3.579MHz clock turn on , CPU and 32.768KHz clock turn on
- Input port wake up function
- 7 interrupt source , 4 external , 3 internal
- **100 pin QFP (EM78862Q) or 84 pin chip (EM78862H)**
- Port key scan function
- Clock frequency 32.768KHz
- Eight R-option pins

LCD

- LCD operation voltage chosen by software
- **Common driver pins : 9**
- Segment driver pins : 60
- 1/4 bias
- 1/8,1/9 duty

III. Application

data bank
message display box

IV. Pin Configuration

EM78862Q

SEG50/P86	81	50	SEG29
SEG51/P87	82	49	SEG28
SEG52/P90	83	48	SEG27
SEG53/P91	84	47	SEG26
SEG54/P92	85	46	SEG25
SEG55/P93	86	45	SEG24
SEG56/P94	87	44	SEG23
SEG57/P95	88	43	SEG22
SEG58/P96	89	42	SEG21
SEG59/P97	90	41	SEG20
P70/INT0	91	40	SEG19
P71/INT1	92	39	SEG18
P72/INT2	93	38	SEG17
P73/INT3	94	37	SEG16
P74	95	36	SEG15
P75	96	35	SEG14
P76	97	34	SEG13
P77	98	33	SEG12
/RESET	99	32	SEG11
NC	100	31	SEG10
	1	30	SEG9
	2	29	SEG8
	3	28	SEG7
PLTC	4	27	SEG6
NC	5	26	SEG5
NC	6	25	SEG4
NC	7	24	SEG3
NC	8	23	SEG2
NC	9	22	SEG1
NC	10	21	SEG0
XIN	11	20	COM0
XOUT	12	19	COM1
VDD	13	18	COM2
COM7	14	17	COM3
COM6	15	16	COM4
COM5	16	15	COM5
COM4	17	14	COM6
COM3	18	13	COM7
COM2	19	12	VDD
COM1	20	11	XOUT
COM0	21	10	XIN
SEG0	22	9	NC
SEG1	23	8	NC
SEG2	24	7	NC
SEG3	25	6	NC
SEG4	26	5	NC
SEG5	27	4	NC
SEG6	28	3	PLTC
SEG7	29	2	NC
SEG8	30	1	NC
SEG9	31	100	NC
SEG10	32	99	/RESET
SEG11	33	98	P77
SEG12	34	97	P76
SEG13	35	96	P75
SEG14	36	95	P74
SEG15	37	94	P73/INT3
SEG16	38	93	P72/INT2
SEG17	39	92	P71/INT1
SEG18	40	91	P70/INT0
SEG19	41	90	SEG59/P97
SEG20	42	89	SEG58/P96
SEG21	43	88	SEG57/P95
SEG22	44	87	SEG56/P94
SEG23	45	86	SEG55/P93
SEG24	46	85	SEG54/P92
SEG25	47	84	SEG53/P91
SEG26	48	83	SEG52/P90
SEG27	49	82	SEG51/P87
SEG28	50	81	SEG50/P86
SEG29	51	80	SEG49/P85
	52	79	SEG48/P84
	53	78	SEG47/P83
	54	77	SEG46/P82
	55	76	SEG45/P81
	56	75	SEG44/P80
	57	74	SEG43/P57
	58	73	SEG42/P56
	59	72	SEG41/P55
	60	71	SEG40/P54
	61	70	NC
	62	69	NC
	63	68	NC
	64	67	NC
	65	66	NC
	66	65	NC
	67	64	NC
	68	63	COM8/P60
	69	62	TEST
	70	61	GND
	71	60	SEG39
	72	59	SEG38
	73	58	SEG37
	74	57	SEG36
	75	56	SEG35
	76	55	SEG34
	77	54	SEG33
	78	53	SEG32
	79	52	SEG31
	80	51	SEG30

Fig1. Pin Assignment

OTP writer PIN NAME	MASK ROM PIN NAME	P.S.
1.VDD	VDD,AVDD	
2.VPP	/RESET	
3.DINCK	P77	
4.ACLK	P76	
5.PGMB	P75	
6.OEB	P74	
7.DATA	P73	
8.GND	GND	

V. Functional Block Diagram

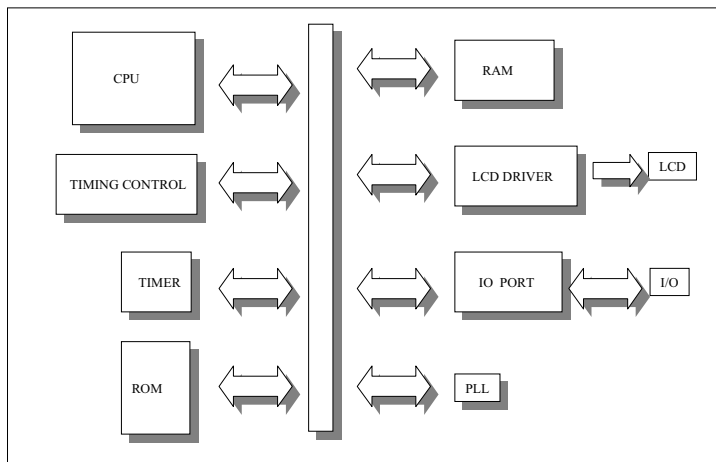

Fig2. Block diagram1

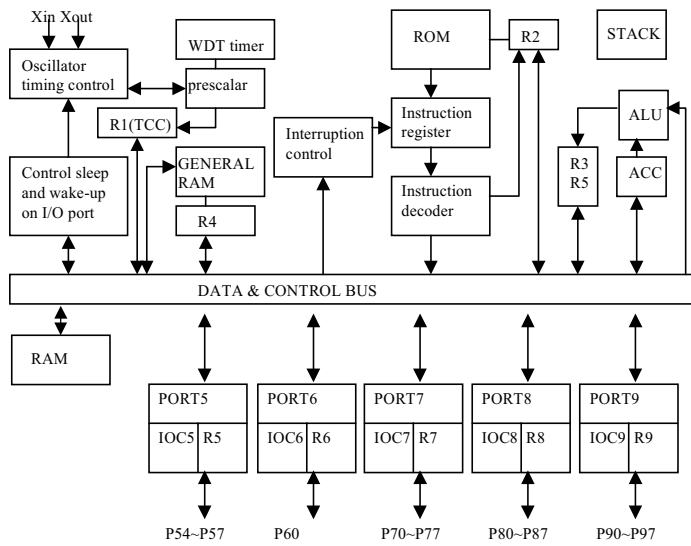

Fig3. Block diagram2

VI.Pin Descriptions

PIN	I/O	DESCRIPTION
VDD	POWER	digital power analog power
GND	POWER	digital ground analog ground
Xtin	I	Input pin for 32.768 kHz oscillator
Xtout	O	Output pin for 32.768 kHz oscillator
COM0..COM8	O	Common driver pins of LCD drivers
SEG0...SEG43	O	Segment driver pins of LCD drivers
SEG44..SEG51	O (PORT8)	PORT9 AS FUNCTION KEY CAN WAKE UP WATCHDOG.
SEG52..SEG59	O (PORT9)	
PLL	I	Phase loop lock capacitor, connect a capacitor 0.01u to 0.047u with AVSS
INT0 INT1 INT2 INT3	PORT7(0) PORT7(1) PORT7(2) PORT7(3) PORT7(4:7)	PORT7(0)~PORT7(3) signal can be interrupt signals. IO port
P5.4 ~P5.7	PORT5	PORT 5 can be INPUT or OUTPUT port each bit. Shared with LCD segment signals
P6.0	PORT6	PORT 6 can be INPUT or OUTPUT port. Shared with LCD common signals
P7.0 ~P7.7	PORT7	PORT 7 can be INPUT or OUTPUT port each bit. Internal Pull high function. Key scan function.
P8.0 ~P8.7	PORT8	PORT 8 can be INPUT or OUTPUT port each bit. And shared with Segment signal.
P9.0 ~P9.7	PORT9	PORT 9 can be INPUT or OUTPUT port each bit. And can be set to wake up watch dog timer. And shared with Segment signal.
TEST	I	Test pin into test mode , normal low
RESET	I	

VII. Functional Descriptions

VII.1 Operational Registers

R0 (Indirect Addressing Register)

* R0 is not a physically implemented register. It is useful as indirect addressing pointer. Any instruction using R0 as register actually accesses data pointed by the RAM Select Register (R4).

R1 (TCC)

* Increased by an external signal edge applied to TCC , or by the instruction cycle clock.

Written and read by the program as any other register.

R2 (Program Counter)

* The structure is depicted in Fig. 4.

* Generates $16K \times 13$ on-chip ROM addresses to the relative programming instruction codes.

* "JMP" instruction allows the direct loading of the low 10 program counter bits.

* "CALL" instruction loads the low 10 bits of the PC, PC+1, and then push into the stack.

* "RET" ("RETL k", "RETI") instruction loads the program counter with the contents at the top of stack.

* "MOV R2,A" allows the loading of an address from the A register to the PC, and the ninth and tenth bits are cleared to "0".

* "ADD R2,A" allows a relative address be added to the current PC, and contents of the ninth and tenth bits are cleared to "0".

* "TBL" allows a relative address be added to the current PC, and contents of the ninth and tenth bits don't change. The most significant bit (A10~A13) will be loaded with the content of bit PS0~PS3 in the status register (R5) upon the execution of a "JMP", "CALL", "ADD R2,A", or "MOV R2,A" instruction.

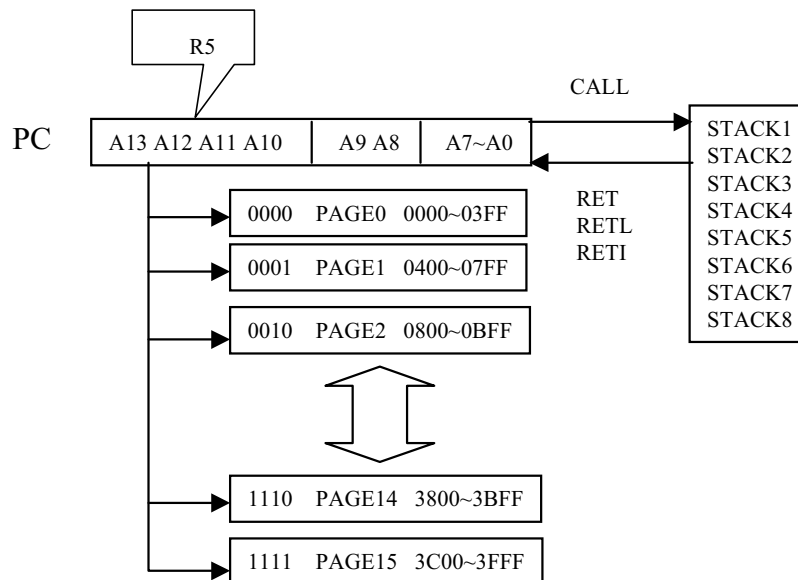

Fig.4 Program counter organization

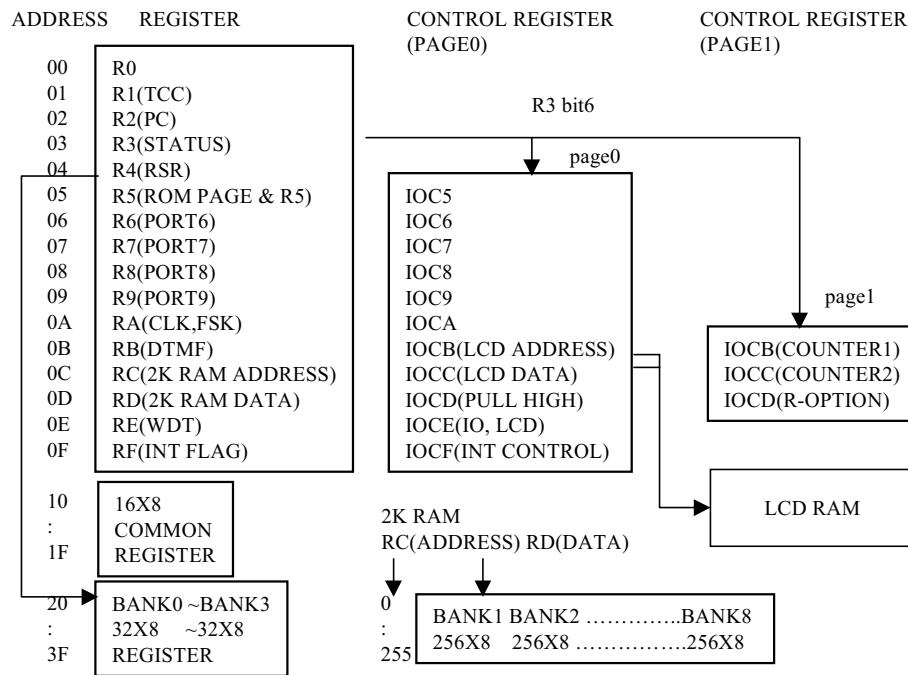

Fig.5 Data memory configuration

R3 (Status Register)

7	6	5	4	3	2	1	0
-	PAGE	-	T	P	Z	DC	C

- * Bit 0 (C) Carry flag
- * Bit 1 (DC) Auxiliary carry flag
- * Bit 2 (Z) Zero flag
- * Bit 3 (P) Power down bit. Set to 1 during power on or by a "WDTC" command and reset to 0 by a "SLEP" command.
- * Bit 4 (T) Time-out bit. Set to 1 by the "SLEP" and "WDTC" command, or during power up and reset to 0 by WDT timeout.

EVENT	T	P	REMARK
WDT wake up from sleep mode	0	0	
WDT time out (not sleep mode)	0	1	
/RESET wake up from sleep	1	0	
power up	1	1	
Low pulse on /RESET	x	x	x .. don't care

- * Bit 5 unused
- * Bit 6 PAGE : change IOCB ~ IOCE to another page , 0/1 => page0 / page1
- * Bit7 unused

R4 (RAM Select Register)

- * Bits 0 ~ 5 are used to select up to 64 registers in the indirect addressing mode.
- * Bits 6 ~ 7 determine which bank is activated among the 4 banks.
- * See the configuration of the data memory in Fig. 5.

R5 (Program Page Select Register)

7	6	5	4	3	2	1	0
R57	R56	R55	R54	PS3	PS2	PS1	PS0

* Bit 0 (PS0) ~ 3 (PS3) Page select bits

Page select bits

PS3	PS2	PS1	PS0	Program memory page (Address)
0	0	0	0	Page 0
0	0	0	1	Page 1
0	0	1	0	Page 2
:	:	:	:	:
1	1	1	0	Page 14
1	1	1	1	Page 15

*User can use PAGE instruction to change page. To maintain program page by user. Otherwise, user can use far jump (FJMP) or far call (FCALL) MACRO instructions to program user's code. And the program page is maintained by ELAN's compiler. It will change user's program by inserting instructions within program.

*Bit4~7 : PORT5 4-bit I/O register

R6 ~ R9 (Port 6 ~ Port 9)

* Four 8-bit I/O registers.

RA (MODE control Register)

7	6	5	4	3	2	1	0
IDLE	/358E	0	1	0	-	-	-

- * Bit0 ~Bit2 unused
- * Bit3:reserved , please clear this bit to '0'.
- * **Bit4:reserved, '1' always.**
- * **Bit5:reserved,please clear this bit to '0'.**

* Bit6(read/write)(PLL enable signal)

0/1=DISABLE/ENABLE

The relation between 32.768K and 3.579M can see Fig8.

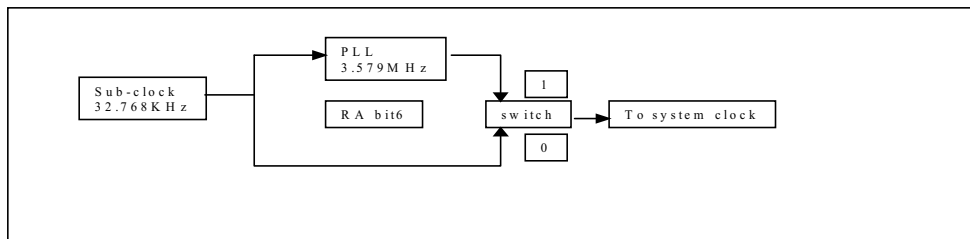

Fig8. The relation between 32.768KHz and 3.579MHz .

* Bit7 IDLE: sleep mode selection bit

0/1=sleep mode/IDLE mode. This bit will decide SLEP instruction which mode to go.

These two modes can be waken up by TCC clock or Watch Dog or PORT9 and run from “SLEP” next instruction.

Wakeup signal	SLEEP mode	IDLE mode	GREEN mode	NORMAL mode
	RA(7,6)=(0,0) + SLEP	RA(7,6)=(1,0) + SLEP	RA(7,6)=(x,0) no SLEP	RA(7,6)=(x,1) no SLEP
TCC time out	X	Wake-up + Interrupt + Next instruction	Interrupt	Interrupt
WDT time out	RESET	Wake-up + Next instruction	RESET	RESET
Port9	RESET	Wake-up + Next instruction	X	X
PORT70~73	X	Wake-up + Interrupt + Next instruction	Interrupt	Interrupt

*P70 ~ P73 's wakeup function is controlled by IOCF(1,2,3) and ENI instruction.

*P70 's wakeup signal is a rising or falling signal defined by CONT REGISTER bit7.

*Port9 ,Port71,Port72 and Port73 's wakeup signal is a falling edge signal.

RB (reserved)

7	6	5	4	3	2	1	0
1	1	1	1	1	1	1	1

* reserved , please set to '1' from bit 7 to bit 0.

RC(2K RAM's address)(read/write)

7	6	5	4	3	2	1	0
RAMA7	RAMA6	RAMA5	RAMA4	RAMA3	RAMA2	RAMA1	RAMA0

* Bit 0 ~ Bit 7 select data bank RAM address up to 256. IOCA is the register for bank selecting.

RD(2K RAM's data)(read/write)

* Bit 0 ~ Bit 8 are 2K RAM;s data transfer register.

User can see IOCA register how to select RAM bank.

RE(LCD Driver,WDT Control)(read/write)

7	6	5	4	3	2	1	0
0	/WDTE	/WUP9H	/WUP9L	0	LCD_C2	LCD_C1	LCD_M

* Bit0 (LCD_M):LCD_M decides the methods, including duty.

* Bit1~Bit2 (LCD_C#):LCD_C# decides the LCD display enable or blanking..

LCD C2,LCD C1	LCD Display Control	LCD M	duty	bias
0 0	change duty Disable(turn off LCD)	0 1	1/9 1/8	1/4 1/4
0 1	Blanking	:	:	:
1 1	LCD display enable	:	:	:

* **Bit3 :Reserved, please clear this bit to '0'.**

* Bit4 (/WUP9L, PORT9 low nibble Wake Up Enable): used to enable the wake-up function of low nibble in PORT9.(1/0=enable/disable)

* Bit5 (/WUP9H, PORT9 high nibble Wake Up Enable): used to enable the wake-up function of high nibble in PORT9.(1/0=enable/disable)

* Bit6 (/WDTE, Watch Dog Timer Enable)

Control bit used to enable Watchdog timer.(1/0=enable/disable)

The relation between Bit4 to Bit6 can see the diagram 9.

* **Bit7: Reserved , please clear this bit to '0'.**

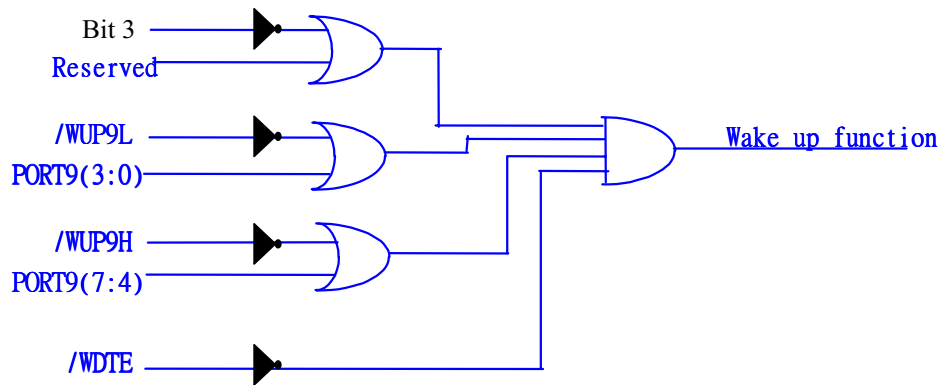

fig.9 Wake up function and control signal

RF (Interrupt Status Register)

7	6	5	4	3	2	1	0
INT3	-	C8_2	C8_1	INT2	INT1	INT0	TCIF

* "1" means interrupt request, "0" means non-interrupt

* Bit 0 (TCIF) TCC timer overflow interrupt flag. Set when TCC timer overflows .

* Bit 1 (INT0) external INT0 pin interrupt flag .

* Bit 2 (INT1) external INT1 pin interrupt flag .

* Bit 3 (INT2) external INT2pin interrupt flag .

* Bit 4 (C8_1) internal 8 bit counter interrupt flag .

* Bit 5 (C8_2) internal 8 bit counter interrupt flag .

* Bit 6 :unused

* Bit 7 (INT3) external INT3 pin interrupt flag.

* High to low edge trigger , Refer to the Interrupt subsection.

* IOCF is the interrupt mask register. User can read and clear.

R10~R3F (General Purpose Register)

- * R10~R3F (Banks 0~3) all are general purpose registers.

VII.2 Special Purpose Registers

A (Accumulator)

- * Internal data transfer, or instruction operand holding
- * It's not an addressable register.

CONT (Control Register)

7	6	5	4	3	2	1	0
INT_EDGE	INT	TS	TE	PAB	PSR2	PSR1	PSR0

- * Bit 0 (PSR0) ~ Bit 2 (PSR2) TCC/WDT prescaler bits.

PSR2	PSR1	PSR0	TCC Rate	WDT Rate
0	0	0	1:2	1:1
0	0	1	1:4	1:2
0	1	0	1:8	1:4
0	1	1	1:16	1:8
1	0	0	1:32	1:16
1	0	1	1:64	1:32
1	1	0	1:128	1:64
1	1	1	1:256	1:128

- * Bit 3 (PAB) Prescaler assignment bit.
0/1 : TCC/WDT
- * Bit 4 (TE) TCC signal edge
0: increment from low to high transition on TCC
1: increment from high to low transition on TCC
- * Bit 5 (TS) TCC signal source
0: internal instruction cycle clock
1: 16.384KHz
- * Bit 6 : (INT)INT enable flag
0: interrupt masked by DISI or hardware interrupt
1: interrupt enabled by ENI/RETI instructions
- * Bit 7 : INT_EDGE
0:P70 's interruption source is a rising edge signal.
1:P70 's interruption source is a falling edge signal.
- * CONT register is readable and writable.

IOC5 (I/O Port Control Register)

7	6	5	4	3	2	1	0
IOC57	IOC56	IOC55	IOC54	0	0	0	P5S

- * Bit0: P5S is switch register for I/O port or LCD signal switching.
0/1= normal I/O port/SEGMENT output .
- * Bit1~3: unused

- * Bit 4 to Bit7 are PORT5 I/O direction control registers.
- * "1" put the relative I/O pin into high impedance, while "0" put the relative I/O pin as output.

IOC6 (I/O Port Control Register)

7	6	5	4	3	2	1	0
0	0	0	0	0	0	0	IOC60

- * Bit0 is I/O direction control registers.
- * **Bit 1 to Bit 7: Reserved, please clear these bits to '0'.**
- * "1" put the relative I/O pin into high impedance, while "0" put the relative I/O pin as output.
- * User can see IOCE register how to switch to normal I/O port.

IOC7 ~ IOC9 (I/O Port Control Register)

- * three I/O direction control registers.
- * "1" put the relative I/O pin into high impedance, while "0" put the relative I/O pin as output.
- * User can see IOCB register how to switch to normal I/O port.

IOCA (2K RAM,IO ,PAGE Control Register)(read/write,initial "00000000")

7	6	5	4	3	2	1	0
P8SH	P8SL	0	0	CALL_3	CALL_2	CALL_1	0

- * Bit0 : unused
- * Bit3~Bit1:"000" to "111" are eight blocks of 2K RAM area. User can use 2K RAM with RD ram address.
- * **Bit4 Reserved, please clear this bit.**
- * Bit 5 unused
- * Bit6: port8 low nibble switch, 0/1= normal I/O port/SEGMENT output .
- * Bit7: port8 high nibble switch , 0/1= normal I/O port/SEGMENT output

IOCB (LCD ADDRESS)

PAGE0 : Bit6 ~ Bit0 = LCDA6 ~ LCDA0

The LCD display data is stored in the data RAM . The relation of data area and COM/SEG pin is as below:

COM8	COM7 ~ COM0	
40H (IOCC Bit 0)	00H (IOCC Bit7 ~ Bit0)	SEG0
41H	01H	SEG1
:	:	:
:	:	:
:	:	:
:	:	:
7AH	4AH	SEG58
7BH	3BH	SEG59
7CH	3CH	Empty
:	:	:
7FH	3FH	Empty

PAGE1 : 8 bit up-counter (COUNTER1) preset and read out register . (write = preset) . After a interruption , it will count from “00”.

IOCC (LCD DATA)

PAGE0 : Bit7 ~ Bit0 = LCD RAM data register

PAGE1 : 8 bit up-counter (COUNTER2) preset and read out register . (write = preset) After a interruption , it will count from “00”.

IOCD (Pull-high Control Register)

PAGE0:

7	6	5	4	3	2	1	0
PH7	PH6	PH5	PH4	PH3	PH2	PH1	PH0

* Bit 0 ~ 7 (/PH#) Control bit used to enable the pull-high of PORT7(#) pin.

- 1: Enable internal pull-high
- 0: Disable internal pull-high

PAGE1:

7	6	5	4	3	2	1	0
RO7	RO6	RO5	RO4	RO3	RO2	RO1	RO0

* Bit 7 ~ 0 (RO7~0) Control bit used to enable the R-OPTION of PORT97~PORT90 pin.

- 1: Enable
- 0: Disable

RO is used for R-OPTION . Setting RO to ‘1’ will enable the status of R-option pin (P90 ~ P97) to read by controller. Clearing RO will disable R-option function. If the R-option function is used, user must connect PORT9 pins to GND by 560K external register . If the register is connected/disconnected , the R9 will read as “0/1” when RO is set to ‘1’.

IOCE (Bias Control Register)

PAGE0 :

7	6	5	4	3	2	1	0
P9SH	P9SL	P6S	Bias3	Bias2	Bias1	0	SC

* Bit 0 :SC (SCAN KEY signal) 0/1 = disable/enable. Once you enable this bit , all of the LCD signal will have a low pulse during a common period. This pulse has 30us width. Please use the procedure to implement the key scan function.

- a. set port7 as input port
- b. set IOCD page0 port7 pull high
- c. enable scan key signal
- d. Once push a key . Set RA(6)=1 and switch to normal mode.
- e. Blank LCD. Disable scan key signal.
- f. Set P9SL =0 ,P9SH =0. Port9 sent probe signal to port7 and read port7. Get the key.
- g. Note!! A probe signal should be delay a instruction at least to another probe signal.
- h. Set P9SH =1,P9SL=1. Port9 as LCD signal. Enable LCD.

(NOTE!! Port8 can apply this method)

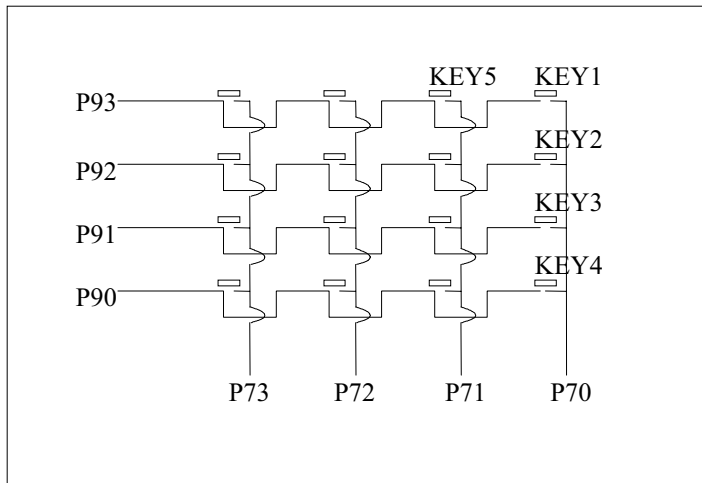

Fig.10. Key scan circuit

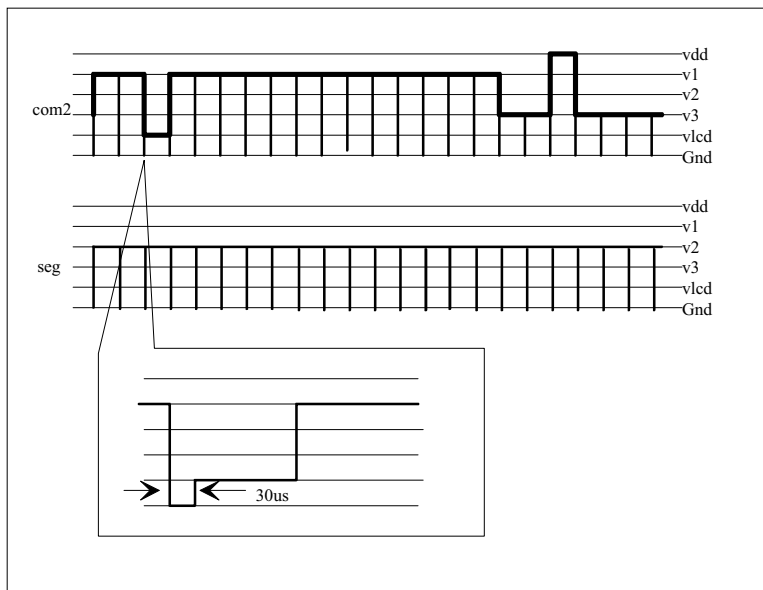

Fig.11.key scan signal

- * Bit 1 :PORT7 PULL HIGH register option. Please use default value.
- * Bit 2~4 (Bias1~Bias3) Control bits used to choose LCD operation voltage .

LCD operate voltage	Vop (VDD 5V)	VDD=5V
000	0.60VDD	3.0V
001	0.66VDD	3.3V
010	0.74VDD	3.7V
011	0.82VDD	4.0V
100	0.87VDD	4.4V
101	0.93VDD	4.7V
110	0.96VDD	4.8V
111	1.00VDD	5.0V

- * Bit5:port6 switch , 0/1= normal I/O port/COMMON output
- * Bit6:port9 low nibble switch , 0/1= normal I/O port/SEGMENT output .
- * Bit7:port9 high nibble switch , 0/1= normal I/O port/SEGMENT output .

PAGE1 :

7	6	5	4	3	2	1	0
OP77	OP76	C2S	C1S	PSC1	PSC0	0	0

- * Bit0: unused
- * Bit1: unused
- * Bit3~Bit2: counter1 prescaler , reset=(0,0)
(PSC1,PSC0) = (0,0)=>1:1 , (0,1)=>1:4 , (1,0)=>1:8 , (1,1)=>reserved
- * Bit4:counter1 source , (0/1)=(32768Hz/3.579MHz if enable) scale=1:1
- * Bit5:counter2 source , (0/1)=(32768Hz/3.579MHz if enable) scale=1:1
- * Bit6:P76 opendrain control (0/1)=(disable/enable)
- * Bit7:P77 opendrain control (0/1)=(disable/enable)

IOCF (Interrupt Mask Register)

7	6	5	4	3	2	1	0
INT3	0	C8_2	C8_1	INT2	INT1	INT0	TCIF

- * Bit 0 ~ 5,7 interrupt enable bit.
0: disable interrupt
1: enable interrupt
- * **Bit 6 : Reserved, please clear this bit to '0'.**
- * IOCF Register is readable and writable.

VII.3 TCC/WDT Prescaler

There is an 8-bit counter available as prescaler for the TCC or WDT. The prescaler is available for the TCC only or WDT only at the same time.

- An 8 bit counter is available for TCC or WDT determined by the status of the bit 3 (PAB) of the CONT register.
- See the prescaler ratio in CONT register.
- Fig. 10 depicts the circuit diagram of TCC/WDT.
- Both TCC and prescaler will be cleared by instructions which write to TCC each time.
- The prescaler will be cleared by the WDTC and SLEP instructions, when assigned to WDT mode.
- The prescaler will not be cleared by SLEP instructions, when assigned to TCC mode.

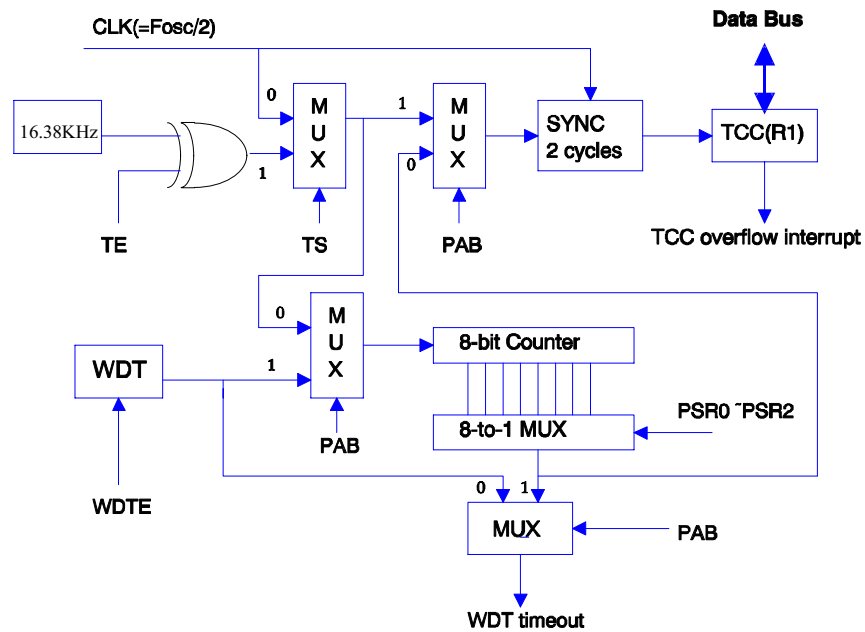

Fig. 10 Block diagram of TCC WDT

Once the RESET occurs, the following functions are performed.

- The oscillator is running, or will be started.
- The Program Counter (R2) is set to all "0".
- When power on, the upper 3 bits of R3 and the upper 2 bits of R4 are cleared.
- The Watchdog timer and prescaler are cleared.
- The Watchdog timer is disabled.
- The CONT register is set to all "1"
- The other register (bit7..bit0)

R5 = PORT	IOC5 = "11110000"	
R6 = PORT	IOC6 = "11111111"	
R7 = PORT	IOC7 = "11111111"	
R8 = PORT	IOC8 = "11111111"	
R9 = PORT	IOC9 = "11111111"	
RA = "x00x0xxx"	IOCA = "00000000"	
RB = "11111111"	Page0 IOCB = "00000000"	Page1 IOCB = "00000000"
RC = "00000000"	Page0 IOCC = "0xxxxxxx"	Page1 IOCC = "00000000"
RD = "xxxxxxx"	Page0 IOCD = "00000000"	Page1 IOCD = "00000000"
RE = "00000000"	Page0 IOCE = "00000000"	Page1 IOCE = "00000000"
RF = "00000000"	IOCF = "00000000"	

The controller can be awakened from SLEEP mode or IDLE mode (execution of "SLEP" instruction, named as SLEEP MODE or IDLE mode) . The wake-up signal list as followed.

Wakeup signal	SLEEP mode	IDLE mode	GREEN mode	NORMAL mode
	RA(7,6)=(0,0) + SLEP	RA(7,6)=(1,0) + SLEP	RA(7,6)=(x,0) no SLEP	RA(7,6)=(x,1) no SLEP
TCC time out	X	Wake-up + Interrupt + Next instruction	Interrupt	Interrupt
WDT time out	RESET	Wake-up + Next instruction	RESET	RESET
Port9	RESET	Wake-up + Next instruction	X	X
PORT70~73	X	Wake-up + Interrupt + Next instruction	Interrupt	Interrupt

*P70 ~ P73 's wakeup function is controlled by IOCF(1,2,3) and ENI instruction.

*P70 's wakeup signal is a rising or falling signal defined by CONT REGISTER bit7.

*Port9 ,Port71,Port72 and Port73 's wakeup signal is a falling edge signal.

*X means no function

VII.6 Interrupt

This IC has internal interrupts which are falling edge triggered, as followed : TCC timer overflow interrupt (internal) , two 8-bit counters overflow interrupt .

If these interrupt sources change signal from high to low , then RF register will generate 'I' flag to corresponding register if you enable IOCF register.

RF is the interrupt status register which records the interrupt request in flag bit. IOCF is the interrupt mask register. Global interrupt is enabled by ENI instruction and is disabled by DISI instruction. When one of the interrupts (when enabled) generated, will cause the next instruction to be fetched from address 008H. Once in the interrupt service routine the source of the interrupt can be determined by polling the flag bits in the RF register. The interrupt flag bit must be cleared in software before leaving the interrupt service routine and enabling interrupts to avoid recursive interrupts.

There are four external interrupt pins including INT0 , INT1 , INT2 , INT3 . And four internal interrupt available.

Internal signals include TCC,CNT1,CNT2.

External interrupt INT0 , INT1 , INT2 , INT3 signals are from PORT7 bit0 to bit3 . If IOCF is enable then these signal will cause interrupt , or these signals will be treated as general input data .

After reset, the next instruction will be fetched from address 000H and the hardware interrupt is 008H.

TCC will go to address 0x08 in GREEN mode or NORMAL mode after time out. And it will run next instruction from "SLEP" instruction. These two cases will set a RF flag.

It is very important to save ACC,R3 and R5 when processing a interruption.

Address	Instruction	Note
0x08	DISI	;Disable interrupt
0x09	MOV A_BUFFER,A	;Save ACC
0x0A	SWAP A_BUFFER	
0x0B	SWAPA 0x03	;Save R3 status
0x0C	MOV R3_BUFFER,A	
0x0D	MOV A,0x05	;Save ROM page register
0x0E	MOV R5_BUFFER,A	
:	:	
:	:	
:	MOV A,R5_BUFFER	;Return R5
:	MOV 0X05,A	
:	SWAPA R3_BUFFER	;Return R3
:	MOV 0X03,A	
:	SWAPA A_BUFFER	;Return ACC
:	RETI	

VII.7 Instruction Set

Instruction set has the following features:

- (1). Every bit of any register can be set, cleared, or tested directly.
- (2). The I/O register can be regarded as general register. That is, the same instruction can operate on I/O register.

The symbol "R" represents a register designator which specifies which one of the 64 registers (including operational registers and general purpose registers) is to be utilized by the instruction. Bits 6 and 7 in R4 determine the selected register bank. "b" represents a bit field designator which selects the number of the bit, located in the register "R", affected by the operation. "k" represents an 8 or 10-bit constant or literal value.

INSTRUCTION BINARY	HEX	MNEMONIC	OPERATION	STATUS AFFECTED
0 0000 0000 0000	0000	NOP	No Operation	None
0 0000 0000 0001	0001	DAA	Decimal Adjust A	C
0 0000 0000 0010	0002	CONTW	A → CONT	None
0 0000 0000 0011	0003	SLEP	0 → WDT, Stop oscillator	T,P
0 0000 0000 0100	0004	WDTC	0 → WDT	T,P
0 0000 0000 rrrr	000r	IOW R	A → IOCR	None
0 0000 0001 0000	0010	ENI	Enable Interrupt	None
0 0000 0001 0001	0011	DISI	Disable Interrupt	None
0 0000 0001 0010	0012	RET	[Top of Stack] → PC	None
0 0000 0001 0011	0013	RETI	[Top of Stack] → PC Enable Interrupt	None
0 0000 0001 0100	0014	CONTR	CONT → A	None
0 0000 0001 rrrr	001r	IOR R	IOCR → A	None
0 0000 0010 0000	0020	TBL	R2+A → R2 bits 9,10 do not clear	Z,C,DC
0 0000 01rr rrrr	00rr	MOV R,A	A → R	None
0 0000 1000 0000	0080	CLRA	0 → A	Z
0 0000 11rr rrrr	00rr	CLR R	0 → R	Z
0 0001 00rr rrrr	01rr	SUB A,R	R-A → A	Z,C,DC
0 0001 01rr rrrr	01rr	SUB R,A	R-A → R	Z,C,DC
0 0001 10rr rrrr	01rr	DECA R	R-1 → A	Z
0 0001 11rr rrrr	01rr	DEC R	R-1 → R	Z
0 0010 00rr rrrr	02rr	OR A,R	A ∨ VR → A	Z
0 0010 01rr rrrr	02rr	OR R,A	A ∨ VR → R	Z
0 0010 10rr rrrr	02rr	AND A,R	A & R → A	Z
0 0010 11rr rrrr	02rr	AND R,A	A & R → R	Z
0 0011 00rr rrrr	03rr	XOR A,R	A ⊕ R → A	Z
0 0011 01rr rrrr	03rr	XOR R,A	A ⊕ R → R	Z
0 0011 10rr rrrr	03rr	ADD A,R	A + R → A	Z,C,DC
0 0011 11rr rrrr	03rr	ADD R,A	A + R → R	Z,C,DC
0 0100 00rr rrrr	04rr	MOV A,R	R → A	Z
0 0100 01rr rrrr	04rr	MOV R,R	R → R	Z
0 0100 10rr rrrr	04rr	COMA R	/R → A	Z
0 0100 11rr rrrr	04rr	COM R	/R → R	Z
0 0101 00rr rrrr	05rr	INCA R	R+1 → A	Z
0 0101 01rr rrrr	05rr	INC R	R+1 → R	Z
0 0101 10rr rrrr	05rr	DJZA R	R-1 → A, skip if zero	None

0	0101	11rr	rrrr	05rr	DJZ R	R-1 → R, skip if zero	None
0	0110	00rr	rrrr	06rr	RRCA R	R(n) → A(n-1) R(0) → C, C → A(7)	C
0	0110	01rr	rrrr	06rr	RRC R	R(n) → R(n-1) R(0) → C, C → R(7)	C
0	0110	10rr	rrrr	06rr	RLCA R	R(n) → A(n+1) R(7) → C, C → A(0)	C
0	0110	11rr	rrrr	06rr	RLC R	R(n) → R(n+1) R(7) → C, C → R(0)	C
0	0111	00rr	rrrr	07rr	SWAPA R	R(0-3) → A(4-7) R(4-7) → A(0-3)	None
0	0111	01rr	rrrr	07rr	SWAP R	R(0-3) ↔ R(4-7)	None
0	0111	10rr	rrrr	07rr	JZA R	R+1 → A, skip if zero	None
0	0111	11rr	rrrr	07rr	JZ R	R+1 → R, skip if zero	None
0	100b	bbrr	rrrr	0xxx	BC R,b	0 → R(b)	None
0	101b	bbrr	rrrr	0xxx	BS R,b	1 → R(b)	None
0	110b	bbrr	rrrr	0xxx	JBC R,b	if R(b)=0, skip	None
0	111b	bbrr	rrrr	0xxx	JBS R,b	if R(b)=1, skip	None
1	00kk	kkkk	kkkk	1kkk	CALL k	PC+1 → [SP] (Page, k) → PC	None
1	01kk	kkkk	kkkk	1kkk	JMP k	(Page, k) → PC	None
1	1000	kkkk	kkkk	18kk	MOV A,k	k → A	None
1	1001	kkkk	kkkk	19kk	OR A,k	A ∨ k → A	Z
1	1010	kkkk	kkkk	1Akk	AND A,k	A & k → A	Z
1	1011	kkkk	kkkk	1Bkk	XOR A,k	A ⊕ k → A	Z
1	1100	kkkk	kkkk	1Ckk	RETL k	k → A, [Top of Stack] → PC	None
1	1101	kkkk	kkkk	1Dkk	SUB A,k	k-A → A	Z,C,DC
1	1110	0000	0001	1E01	INT	PC+1 → [SP] 001H → PC	None
1	1110	1000	kkkk	1E8k	PAGE k	K → R5(3:0)	None
1	1111	kkkk	kkkk	1Fkk	ADD A,k	k+A → A	Z,C,DC

VII.8 CODE Option Register

The data bank IC has one CODE option register which is not part of the normal program memory. The option bits cannot be accessed during normal program execution.

7	6	5	4	3	2	1	0
-	-	-	-	-	-	/POVD	MCLK

* Bit 0 : main clock selection. 0/1 = 3.58MHZ / 1.84MHZ

* Bit 1 : (/POVD) : Power on voltage detector.

0: enable

1: disable

/POVD	2.2V reset	power on reset	Low power detect without reset	Low power detect controlled by RA(5)	sleep mode current
1	no	yes	Yes	Yes	1uA
0	yes	yes	Yes	yes	15uA

* Bits 2~7 : unused, must be "0"s.

VII 9 LCD Driver

The data bank IC can drive LCD directly and has 60 segments and 16 commons that can drive 60*16 dots totally. LCD block is made up of LCD driver , display RAM, segment output pins , common output pins and LCD operating power supply pins.

Duty , bias , the number of segment , the number of common and frame frequency are determined by LCD mode register . LCD control register.

The basic structure contains a timing control which uses the basic frequency 32.768KHz to generate the proper timing for different duty and display access. RE register is a command register for LCD driver, the LCD display(disable, enable, blanking) is controlled by LCD_C and the driving duty and bias is decided by LCD_M and the display data is stored in data RAM which address and data access controlled by registers IOCB and IOCC.

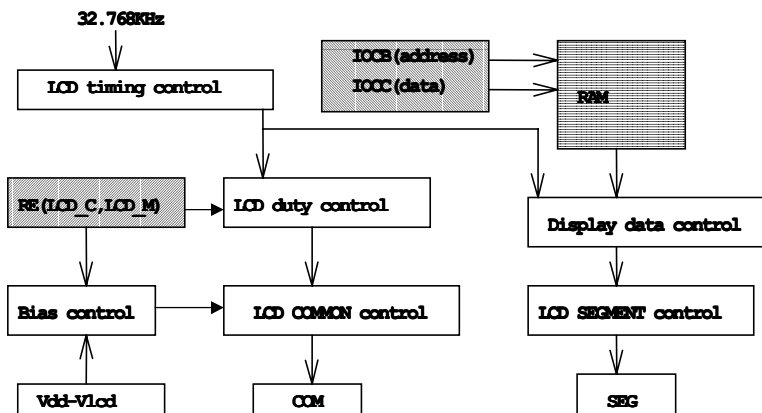

Fig16. LCD DRIVER CONTROL

VII.9.1 LCD Driver Control

RE(LCD Driver Control)(initial state "00000000")

7	6	5	4	3	2	1	0
-	-	-	-	-	LCD_C2	LCD_C1	LCD_M

*Bit0 (LCD_M):LCD_M decides the methods, including duty, bias, and frame frequency.

*Bit1~Bit2 (LCD_C#):LCD_C# decides the LCD display enable or blanking. change the display duty must set the LCD_C to "00".

LCD_C2,LCD_C1	LCD Display Control	LCD_M	duty	bias
0 0	change duty	0	1/9	1/4
	Disable(turn off LCD)	1	1/8	1/4
0 1	Blanking	:	:	:
1 1	LCD display enable	:	:	:

VII.9.2 LCD display area

The LCD display data is stored in the data RAM . The relation of data area and COM/SEG pin is as below:

COM8	COM7 ~ COM0	
40H (Bit 0)	00H (Bit7 ~ Bit0)	SEG0
41H	01H	SEG1
:	:	:
:	:	:
7BH	3BH	SEG59
7CH	3CH	Empty
7DH	3DH	Empty
7EH	3EH	Empty
7FH	3FH	Empty

*IOCB(LCD Display RAM address)

7	6	5	4	3	2	1	0
-	LCDA6	LCDA5	LCDA4	LCDA3	LCDA2	LCDA1	LCDA0

Bit 0 ~ Bit 6 select LCD Display RAM address up to 120.

LCD RAM can be write whether in enable or disable mode and read only in disable mode.

*IOCC(LCD Display data) : Bit 0 ~ Bit 8 are LCD data.

VII.9.3 LCD COM and SEG signal

* COM signal : The number of COM pins varies according to the duty cycle used, as following: in 1/8 duty mode COM8 must be open. in 1/9 duty mode COM0 ~ COM8 pins must be used.

	COM0	COM1	COM2	COM3	COM4	COM5	COM6	COM7	COM8
1/8	o	o	o	o	o	o	o	o	x
1/9	o	o	o	o	o	o	o	o	o

x:open,o:select

* SEG signal: The 60 segment signal pins are connected to the corresponding display RAM address 00h to 3Bh. The high byte and the low byte bit7 down to bit0 are correlated to COM8 to COM0 respectively .
When a bit of display RAM is 1, a select signal is sent to the corresponding segment pin, and when the bit is 0 , a non-select signal is sent to the corresponding segment pin.

*COM, SEG and Select/Non-select signal is shown as following:

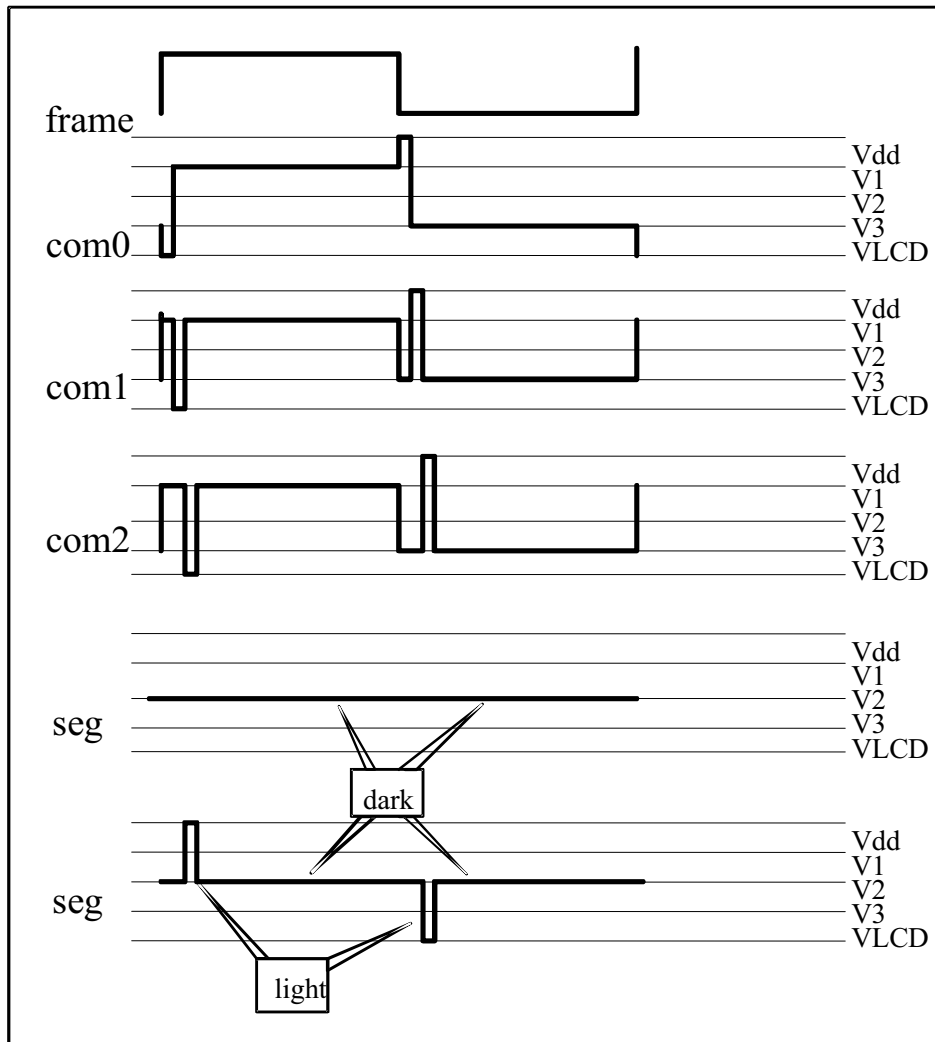

Fig.17 Lcd wave 1/4 bias

VII.9.4 LCD Bias control

IOCE (Bias Control Register)

7	6	5	4	3	2	1	0
			Bias3	Bias2	Bias1		

* Bit 2~4 (Bias1~Bias3) Control bits used to choose LCD operation voltage . The circuit can refer ti figure15.

LCD operate voltage	Vop (VDD 5V)	VDD=5V
000	0.60VDD	3.0V
001	0.66VDD	3.3V
010	0.74VDD	3.7V
011	0.82VDD	4.0V
100	0.87VDD	4.4V
101	0.93VDD	4.7V
110	0.96VDD	4.8V
111	1.00VDD	5.0V

* Bit 5~7 unused

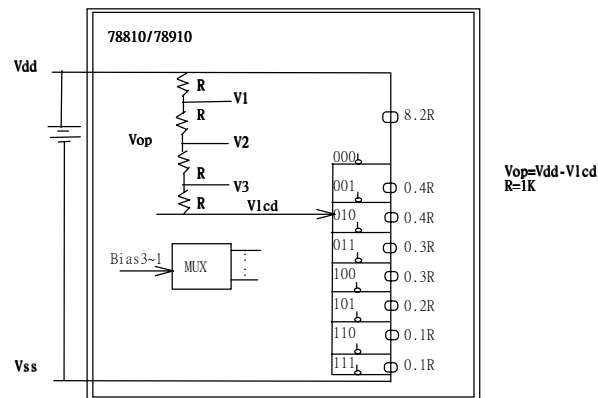

Fig.18 LCD bias circuit

VIII. Absolute Operation Maximum Ratings

RATING	SYMBOL	VALUE	UNIT
DC SUPPLY VOLTAGE	V _{dd}	-0.3 To 6	V
INPUT VOLTAGE	V _{in}	-0.5 TO V _{dd} +0.5	V
OPERATING TEMPERATURE RANGE	T _a	0 TO 70	°C

IX DC Electrical Characteristic

(T_a=0°C ~ 70°C, V_{DD}=5V±5%, V_{SS}=0V)

Symbol	Parameter	Condition	Min	Typ	Max	Unit
IIL1	Input Leakage Current for input pins	V _{IN} = V _{DD} , V _{SS}			±1	μA
IIL2	Input Leakage Current for bi-directional pins	V _{IN} = V _{DD} , V _{SS}			±1	μA
VIH	Input High Voltage		2.5			V
VIL	Input Low Voltage				0.8	V
VIHT	Input High Threshold Voltage	/RESET, TCC, RDET1	2.0			V
VILT	Input Low Threshold Voltage	/RESET, TCC, RDET1			0.8	V
VIHX	Clock Input High Voltage	OSCI	3.5			V
VILX	Clock Input Low Voltage	OSCI			1.5	V
VHscan	Key scan Input High Voltage	Port6 for key scan	3.5			V
VLscan	Key scan Input Low Voltage	Port6 for key scan			1.5	V
VOH1	Output High Voltage (port6,7,8)	I _{OH} = -1.6mA	2.4			V
	(port9)	I _{OH} = -6.0mA	2.4			V
VOL1	Output Low Voltage (port6,7,8)	I _{OL} = 1.6mA			0.4	V
	(port9)	I _{OL} = 6.0mA			0.4	V
Vcom	Com voltage drop	I _o =+/- 50 uA	-	-	2.9	V
Vseg	Segment voltage drop	I _o =+/- 50 uA	-	-	3.8	V
Vlcd	LCD drive reference voltage	Contrast adjustment				
IPH	Pull-high current	Pull-high active input pin at V _{SS}		-10	-15	μA
ISB1	Power down current (SLEEP mode)	All input and I/O pin at V _{DD} , output pin floating, WDT disabled		1	4	μA
ISB2	Power down current (IDLE mode)	All input and I/O pin at V _{DD} , output pin floating, WDT disabled, LCD enable		50	70	μA
ISB3	Low clock current (GREEN mode)	CLK=32.768KHz, All input and I/O pin at V _{DD} , output pin floating, WDT disabled, LCD enable		80	100	μA
ICC	Operating supply current (NORMAL mode)	/RESET=High, CLK=3.579MHz, output pin floating, LCD enable		1.5	1.9	mA

(Ta=0°C ~ 70°C, VDD=3V±5%, VSS=0V)

Symbol	Parameter	Condition	Min	Typ	Max	Unit
ISB1	Power down current (SLEEP mode)	All input and I/O pin at VDD, output pin floating, WDT disabled		1	2	μA
ISB2	Power down current (IDLE mode)	All input and I/O pin at VDD, output pin floating, WDT disabled, LCD enable		25	35	μA
ISB3	Low clock current (GREEN mode)	CLK=32.768KHz, All input and I/O pin at VDD, output pin floating, WDT disabled, LCD enable		35	45	μA
ICC	Operating supply current (NORMAL mode)	/RESET=High, CLK=3.579MHz, output pin floating, LCD enable		0.9	1.2	mA

IX AC Electrical Characteristic

(Ta=0°C ~ 70°C, VDD=5V, VSS=0V)

Symbol	Parameter	Conditions	Min	Typ	Max	Unit
Dclk	Input CLK duty cycle		45	50	55	%
Tins	Instruction cycle time	32.768K 3.579M		60 550		us ns
Tdrh	Device delay hold time			18		ms
Ttcc	TCC input period	Note 1	(Tins+20)/N			ns
Twdt	Watchdog timer period	Ta = 25°C		18		ms

Note 1: N= selected prescaler ratio.

Description	Symbol	Min	Typ	Max	Unit
OSC start up(32.768KHz) (3.579MHz PLL)	Tosc	--		400 10	Ms

XI. Timing Diagrams

AC Test Input/Output Waveform

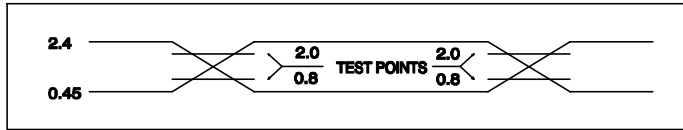

AC Testing: Input are driven at 2.4V for logic "1", and 0.45V for logic "0". Timing measurements are made at 2.0V for logic "1", and 0.8V for logic "0".

RESET Timing

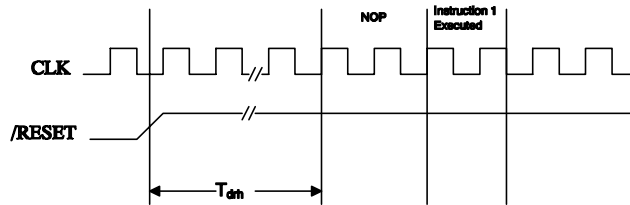

TCC Input Timing

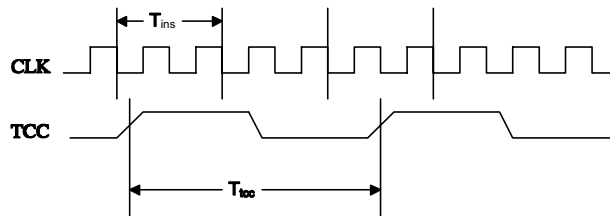

Fig.20 AC timing

XII. Application Circuit

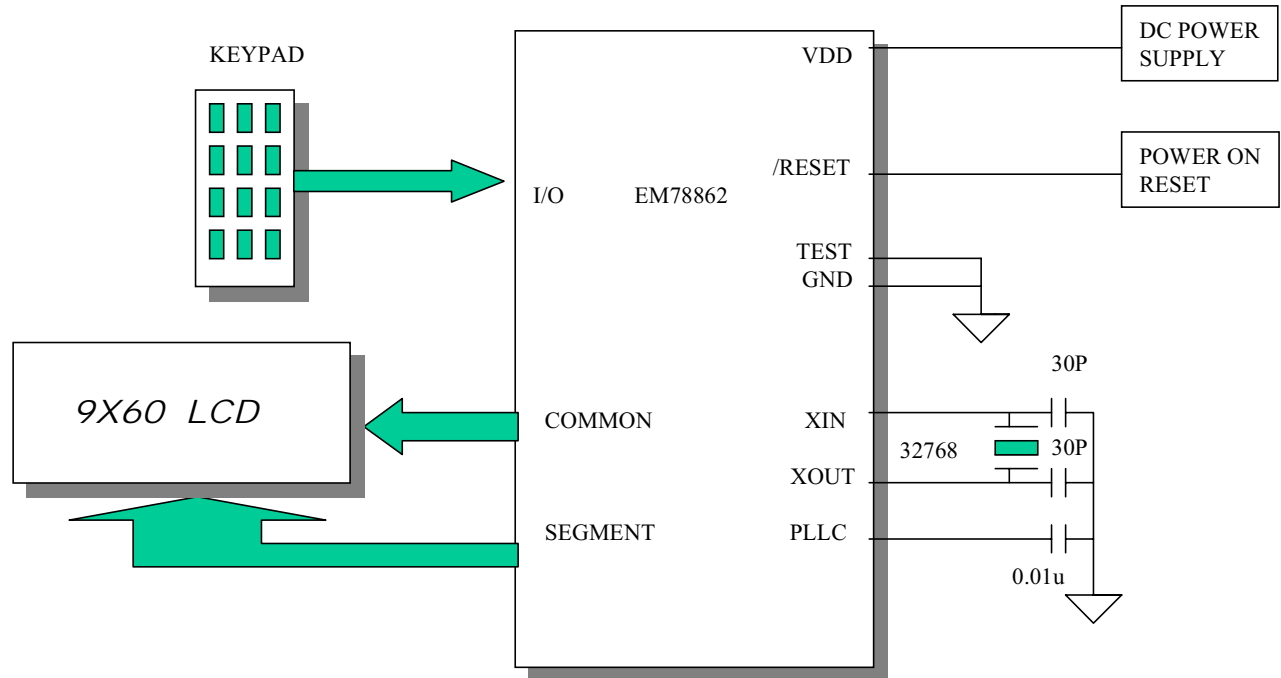

Fig23. APPLICATION CIRCUIT