

Three-PLL General Purpose FLASH Programmable Clock Generator

Features

- Three integrated phase-locked loops
- Ultra-wide divide counters (eight-bit Q, eleven-bit P, and seven-bit post divide)
- Improved linear crystal load capacitors
- Flash programmability
- Field programmability
- Low-jitter, high-accuracy outputs
- Power-management options (Shutdown, OE, Suspend)
- Configurable crystal drive strength
- Frequency select option via external LVTTTL Input
- 3.3V operation
- Eight-pin SOIC package
- CyClocks RT™ support

Benefits

- Generates up to three unique frequencies on three outputs up to 200 MHz from an external source. Functional upgrade for current CY2081 family.
- Allows for 0 ppm frequency generation and frequency conversion under the most demanding applications
- Improves frequency accuracy over temperature, age, process, and initial offset

- Non-volatile programming enables easy customization, ultra-fast turnaround, performance tweaking, design timing margin testing, inventory control, lower part count, and more secure product supply. Can also be programmed multiple times which reduces programming errors and provides an easy upgrade path for existing designs
- In-house programming of samples and prototype quantities is available using the CY3672 FTG development Kit. Production quantities are available through Cypress's value-added distribution partners or by using third party programmers from BP Microsystems, HiLo Systems, and others.
- Performance suitable for high-end multimedia, communications, industrial, A/D converters, and consumer applications
- Supports numerous low-power application schemes and reduces EMI by allowing unused outputs to be turned off
- Adjust crystal drive strength for compatibility with virtually all crystals
- External frequency select option for PLL1, CLKA, and CLKB
- Industry standard supply voltage
- Industry standard packaging saves on board space
- Easy-to-use software support for design entry

Logic Block Diagram

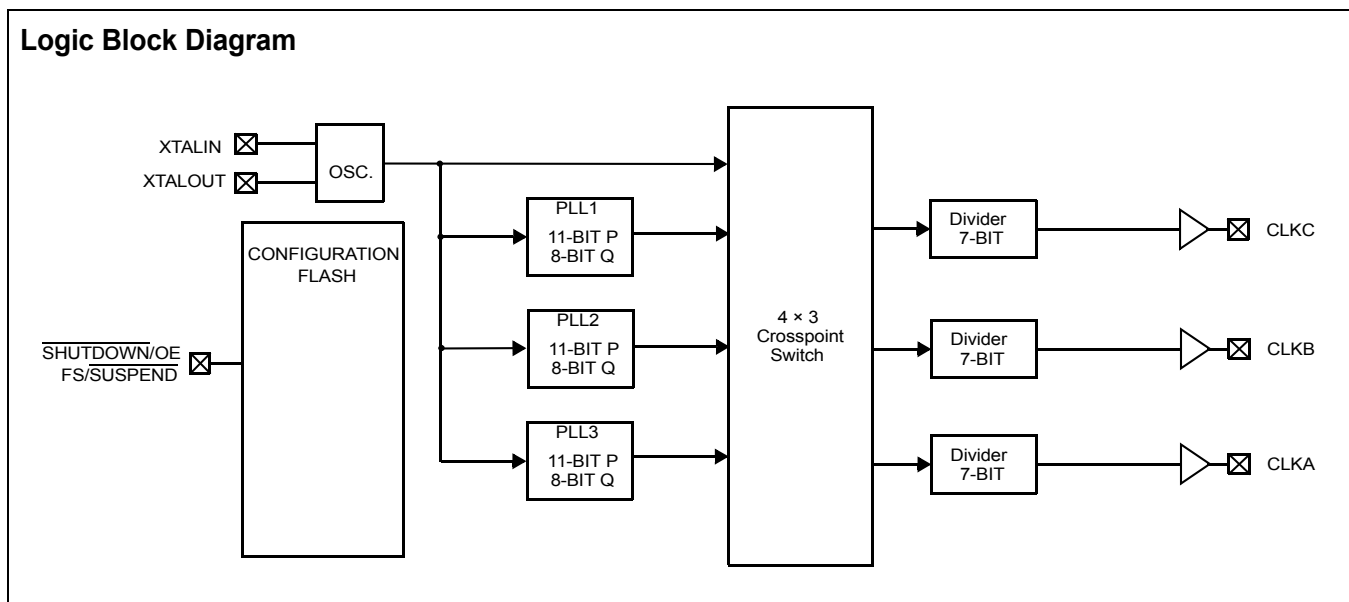

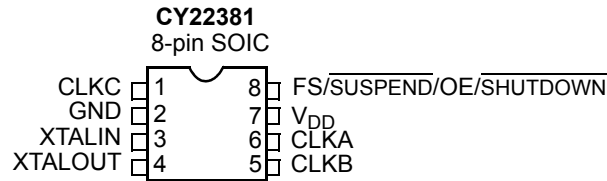
Pin Configuration

Selector Guide

Part Number	Outputs	Input Frequency Range	Output Frequency Range	Specifics
CY22381FC	3	8 MHz – 30 MHz (external crystal) 1 MHz – 166 MHz (reference clock)	Up to 200 MHz	Commercial Temperature
CY22381FI	3	8 MHz – 30 MHz (external crystal) 1 MHz – 150 MHz (reference clock)	Up to 166 MHz	Industrial Temperature

Pin Summary

Name	Pin Number	Description
CLKC	1	Configurable clock output C
GND	2	Ground
XTALIN	3	Reference crystal input or external reference clock input
XTALOUT	4	Reference crystal feedback (float if XTALIN is driven by external reference clock)
CLKB	5	Configurable clock output B
CLKA	6	Configurable clock output A
V _{DD}	7	Power supply
FS/SUSPEND/ OE/SHUTDOWN	8	General Purpose Input. Can be Frequency Control, Suspend mode control, Output Enable, or full-chip shutdown.

Operation

The CY22381 is an upgrade to the existing CY2081. The new device has a wider frequency range, greater flexibility, improved performance, and incorporates many features that reduce PLL sensitivity to external system issues.

The device has three PLLs that allow each output to operate at an independent frequencies. These three PLLs are completely programmable.

Configurable PLLs

PLL1 generates a frequency that is equal to the reference divided by an eight-bit divider (Q) and multiplied by an 11-bit divider in the PLL feedback loop (P). The output of PLL1 is sent to the crosspoint switch. The frequency of PLL1 can optionally be changed by using the external CMOS general purpose input. See the following section on “General-Purpose Input” for more detail.

PLL2 generates a frequency that is equal to the reference divided by an eight-bit divider (Q) and multiplied by an 11-bit divider in the PLL feedback loop (P). The output of PLL2 is sent to the crosspoint switch.

PLL3 generates a frequency that is equal to the reference divided by an eight-bit divider (Q) and multiplied by an 11-bit divider in the PLL feedback loop (P). The output of PLL3 is sent to the cross-point switch.

General-Purpose Input

The CY22381 features an output control pin (pin 8) that can be programmed to control one of four features.

When programmed as a Frequency Select (FS), the input can select between two arbitrarily programmed frequency settings. The Frequency Select can change the following; the frequency of PLL1, the output divider of CLKB, and the output divider of CLKA. Any divider change as a result of switching the FS input is guaranteed to be glitch free.

The general-purpose input can simultaneously control the Suspend feature, turning off a set of PLLs and outputs determined during programming.

When programmed as an Output Enable (OE) the input forces all outputs to be placed in a three-state condition when LOW.

When programmed as a Shutdown, the input forces a full chip shutdown mode when LOW.

Crystal Input

The input crystal oscillator is an important feature of this device because of its flexibility and performance features.

The oscillator inverter has programmable drive strength. This allows for maximum compatibility with crystals from various manufacturers, processes, performances, and qualities.

The input load capacitors are placed on-die to reduce external component cost. These capacitors are true parallel-plate capacitors for ultra-linear performance. These were chosen to reduce the frequency shift that occurs when non-linear load

capacitance interacts with load, bias, supply, and temperature changes. Non-linear (FET gate) crystal load capacitors should not be used for MPEG, POTS dial tone, communications, or other applications that are sensitive to absolute frequency requirements.

The value of the load capacitors is determined by six bits in a programmable register. The load capacitance can be set with a resolution of 0.375 pF for a total crystal load range of 6 pF to 30 pF.

For driven clock inputs the input load capacitors may be completely bypassed. This enables the clock chip to accept driven frequency inputs up to 166 MHz. If the application requires a driven input, then XTALOUT must be left floating.

Output Configuration

Under normal operation there are four internal frequency sources that may be routed via a programmable crosspoint switch to any of the three outputs via programmable seven-bit output dividers. The four sources are: reference, PLL1, PLL2, and PLL3. The following is a description of each output.

CLKA's output originates from the crosspoint switch and goes through a programmable seven-bit post divider. The seven-bit post divider derives its value from one of two programmable registers controlled by FS.

CLKB's output originates from the crosspoint switch and goes through a programmable seven-bit post divider. The seven-bit post divider derives its value from one of two programmable registers controlled by FS.

CLKC's output originates from the crosspoint switch and goes through a programmable seven-bit post divider. The seven-bit post divider derives its value from one programmable register.

The Clock outputs have been designed to drive a single point load with a total lumped load capacitance of 15 pF. While driving multiple loads is possible with the proper termination, it is generally not recommended.

Power-Saving Features

When configured as OE, the general-purpose input three-states all outputs when pulled LOW. When configured as Shutdown, a LOW on this pin three-states all outputs and shuts off the PLLs, counters, the reference oscillator, and all other active components. The resulting current on the V_{DD} pins will be less than 5 μ A (typical). After leaving shutdown mode, the PLLs will have to relock.

When configured as SUSPEND, the general-purpose input can be configured to shut down a customizable set of outputs and/or PLLs, when LOW. All PLLs and any of the outputs can be shut off in nearly any combination. The only limitation is that if a PLL is shut off, all outputs derived from it must also be shut off. Suspending a PLL shuts off all associated logic, while suspending an output forces a three-state condition.

Improving Jitter

Jitter Optimization Control is useful in mitigating problems related to similar clocks switching at the same moment and causing excess jitter. If one PLL is driving more than one output, the negative phase of the PLL can be selected for one of the outputs. This prevents the output edges from aligning, allowing superior jitter performance.

CyClocks RT Software

CyClocks RT is our second-generation application that allows users to configure this device. The easy-to-use interface offers complete control of the many features of this family including input frequency, PLL and output frequencies, and different functional options. Data sheet frequency range limitations are checked and performance tuning is automatically applied. You can download a free copy of CyClocks RT on Cypress's web site at <http://www.cypress.com>.

Maximum Ratings

(Above which the useful life may be impaired. For user guidelines, not tested.)

Supply Voltage -0.5V to +7.0V
 DC Input Voltage -0.5V to + (V_{DD} + 0.5V)
 Storage Temperature -65°C to +125°C

Junction Temperature 125°C
 Data Retention @ T_j = 125°C > 10 years
 Maximum Programming Cycles 100
 Package Power Dissipation 250 mW
 Static Discharge Voltage
 (per MIL-STD-883, Method 3015) ≥ 2000V
 Latch up (per JEDEC 17) ≥ ±200 mA

Operating Conditions^[1]

Parameter	Description	Min.	Typ.	Max.	Unit
V _{DD}	Supply Voltage	3.135	3.3	3.465	V
T _A	Commercial Operating Temperature, Ambient	0	–	+70	°C
	Industrial Operating Temperature, Ambient	–40	–	+85	°C
C _{LOAD_OUT}	Max. Load Capacitance	–	–	15	pF
f _{REF}	External Reference Crystal	8	–	30	MHz
	External Reference Clock ^[2] , Commercial	1	–	166	MHz
	External Reference Clock ^[2] , Industrial	1	–	150	MHz
t _{PU}	Power-up time for all VDD's to reach minimum specified voltage (power ramps must be monotonic)	0.05	–	500	ms

Electrical Characteristics

Parameter	Description	Conditions	Min.	Typ.	Max.	Unit
I _{OH}	Output High Current ^[3]	V _{OH} = V _{DD} – 0.5, V _{DD} = 3.3 V	12	24	–	mA
I _{OL}	Output Low Current ^[3]	V _{OL} = 0.5V, V _{DD} = 3.3 V	12	24	–	mA
C _{XTAL_MIN}	Crystal Load Capacitance ^[3]	Capload at minimum setting	–	6	–	pF
C _{XTAL_MAX}	Crystal Load Capacitance ^[3]	Capload at maximum setting	–	30	–	pF
C _{IN}	Input Pin Capacitance ^[3]	Except crystal pins	–	7	–	pF
V _{IH}	HIGH-level Input Voltage	CMOS levels, % of V _{DD}	70%	–	–	V _{DD}
V _{IL}	LOW-level Input Voltage	CMOS levels, % of V _{DD}	–	–	30%	V _{DD}
I _{IH}	Input HIGH Current	V _{IN} = V _{DD} – 0.3 V	–	<1	10	μA
I _{IL}	Input LOW Current	V _{IN} = +0.3 V	–	<1	10	μA
I _{OZ}	Output Leakage Current	Three-state outputs	–	–	10	μA
I _{DD}	Total Power Supply Current	3.3 V Power Supply; 3 outputs @ 50 MHz	–	35	–	mA
		3.3 V Power Supply; 3 outputs @ 166 MHz	–	70	–	mA
I _{DDs}	Total Power Supply Current in Shutdown Mode	Shut-down active	–	5	20	μA

Notes:

1. Unless otherwise noted, Electrical and Switching Characteristics are guaranteed across these operating conditions.
2. External input reference clock must have a duty cycle between 40% and 60%, measured at V_{DD}/2.
3. Guaranteed by design, not 100% tested.

Switching Characteristics

Parameter	Name	Description	Min.	Typ.	Max.	Unit
1/t ₁	Output Frequency ^[3, 4]	Clock output limit, Commercial	–	–	200	MHz
		Clock output limit, Industrial	–	–	166	MHz
t ₂	Output Duty Cycle ^[3, 5]	Duty cycle for outputs, defined as $t_2 \div t_1$, Fout < 100 MHz, divider ≥ 2 , measured at V _{DD} /2	45%	50%	55%	
		Duty cycle for outputs, defined as $t_2 \div t_1$, Fout > 100 MHz or divider = 1, measured at V _{DD} /2	40%	50%	60%	
t ₃	Rising Edge Slew Rate ^[3]	Output clock rise time, 20% to 80% of V _{DD}	0.75	1.4	–	V/ns
t ₄	Falling Edge Slew Rate ^[3]	Output clock fall time, 20% to 80% of V _{DD}	0.75	1.4	–	V/ns
t ₅	Output Three-state Timing ^[3]	Time for output to enter or leave three-state mode after SHUTDOWN/OE switches	–	150	300	ns
t ₆	Clock Jitter ^[3, 6]	Peak-to-peak period jitter, CLK outputs measured at V _{DD} /2	–	200	–	ps
t ₇	Lock Time ^[3]	PLL Lock Time from Power-up	–	1.0	3	ms

Switching Waveforms

All Outputs, Duty Cycle and Rise/Fall Time

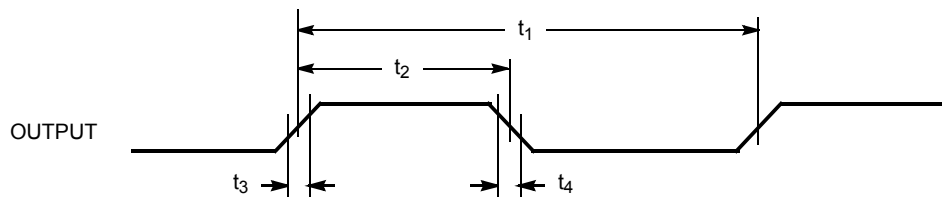

Output Three-State Timing

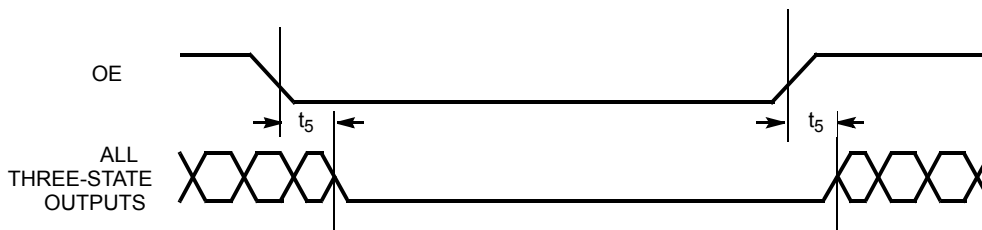

CLK Output Jitter

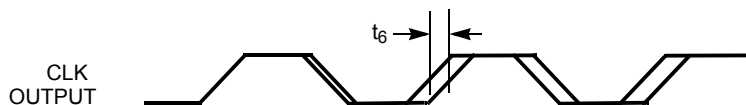

Notes:

4. Guaranteed to meet 20% – 80% output thresholds and duty cycle specifications.
5. Reference Output duty cycle depends on XTALIN duty cycle.
6. Jitter varies significantly with configuration. Reference Output jitter depends on XTALIN jitter and edge rate.

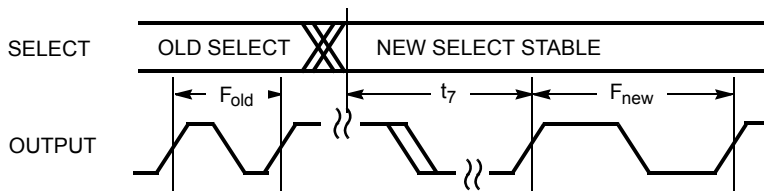
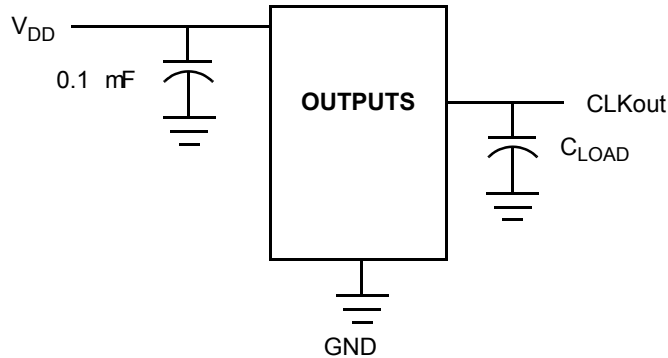
Switching Waveforms (continued)
Frequency Change

Test Circuit

Ordering Information

Ordering Code	Package Type	Operating Range	Operating Voltage
CY22381FC	8-SOIC	Commercial (T _A =0°C to 70°C)	3.3V
CY22381FCT	8-SOIC – Tape and Reel	Commercial (T _A =0°C to 70°C)	3.3V
CY22381FI	8-SOIC	Industrial (T _A =-40°C to 85°C)	3.3V
CY22381FIT	8-SOIC – Tape and Reel	Industrial (T _A =-40°C to 85°C)	3.3V
CY22381SC-xxx ^[7]	8-SOIC	Commercial (T _A =0°C to 70°C)	3.3V
CY22381SC-xxxT ^[7]	8-SOIC – Tape and Reel	Commercial (T _A =0°C to 70°C)	3.3V
CY22381SI-xxx ^[7]	8-SOIC	Industrial (T _A =-40°C to 85°C)	3.3V
CY22381SI-xxxT ^[7]	8-SOIC – Tape and Reel	Industrial (T _A =-40°C to 85°C)	3.3V
CY3672			
Lead-Free			
CY22381FXC	8-SOIC	Commercial (T _A =0°C to 70°C)	3.3V
CY22381FXCT	8-SOIC – Tape and Reel	Commercial (T _A =0°C to 70°C)	3.3V
CY22381FXI	8-SOIC	Industrial (T _A =-40°C to 85°C)	3.3V
CY22381FXIT	8-SOIC – Tape and Reel	Industrial (T _A =-40°C to 85°C)	3.3V
CY22381SXC-xxx ^[7]	8-SOIC	Commercial (T _A =0°C to 70°C)	3.3V
CY22381SXC-xxxT ^[7]	8-SOIC – Tape and Reel	Commercial (T _A =0°C to 70°C)	3.3V
CY22381SXI-xxx ^[7]	8-SOIC	Industrial (T _A =-40°C to 85°C)	3.3V
CY22381SXI-xxxT ^[7]	8-SOIC – Tape and Reel	Industrial (T _A =-40°C to 85°C)	3.3V

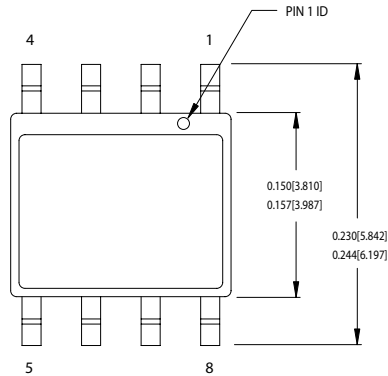
Notes:

7. The CY22381SC-xxx and CY22381SI-xxx are factory programmed configurations. Factory programming is available for high-volume design opportunities of 100Ku/year or more in production. For more details, contact your local Cypress FAE or Cypress Sales Representative.

Package Drawing and Dimensions
8-lead (150-Mil) SOIC S8

1. DIMENSIONS IN INCHES[MM] MIN. MAX.
2. PIN 1 ID IS OPTIONAL, ROUND ON SINGLE LEADFRAME RECTANGULAR ON MATRIX LEADFRAME
3. REFERENCE JEDEC MS-012
4. PACKAGE WEIGHT 0.07gms

PART #
S08.15 STANDARD PKG.
SZ08.15 LEAD FREE PKG.

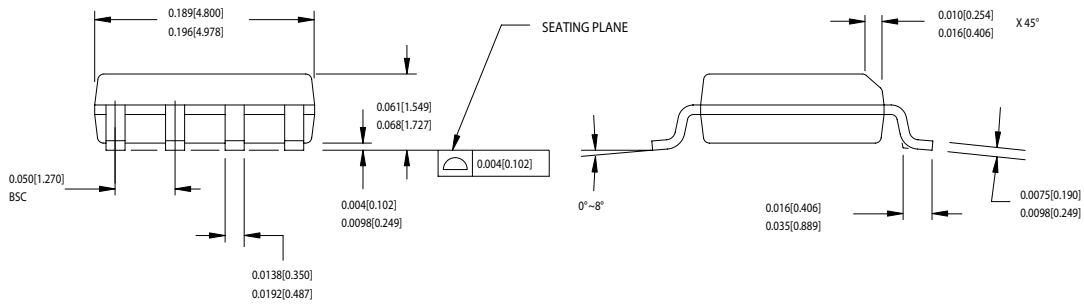

51-85066-°C

CYClocks RT is a trademark of Cypress Semiconductor Corporation. All product and company names are the trademarks of their respective holders.

Document History Page

Document Title: CY22381 Three-PLL General Purpose Flash Programmable Clock Generator				
Document Number: 38-07012				
REV.	ECN NO.	Issue Date	Orig. of Change	Description of Change
**	106737	07/03/01	TLG	New data sheet
*A	108514	08/23/01	JWK	Updated based on characterization results Removed "Preliminary" heading Removed soldering temperature rating Split crystal load into two typical specs representing digital settings range Changed t_5 max to 300 ns Changed t_6 typical to 200 ps Changed t_7 typical to 1.0 ms
*B	110053	12/10/01	CKN	Changed from preliminary to final
*C	121863	12/14/02	RBI	Added power-up requirements to Operating Conditions information
*D	279431	See ECN	RGL	Added lead-free devices