

Features

- Generates standard CCITT R1 MF tones
- Digital input control
- Linear (analog) output
- Power output capable of driving standard line
- 14-pin DIP
- Single 5-Volt supply
- Inexpensive 3.58 MHz time base

Applications

- Telephone systems
- Test equipment

Description

The M-993 is a monolithic CMOS integrated circuit designed to generate multifrequency (MF) tone pairs for use in trunk signaling. The tones generated conform to CCITT R1 signal recommendations and to AT&T MF standards. The M-993 permits design engineers to implement a highly accurate MF sender with a minimum of space, power, and added components. The accuracy of the tone frequencies is assured through use of an easily obtained 3.58 MHz color burst crystal or an external 3.58 MHz clock source.

Ordering Information

Part #	Description
M-993	14-pin plastic DIP

Pin Diagram

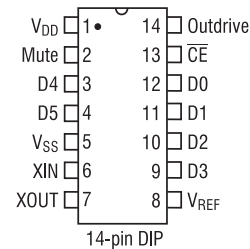

Block Diagram

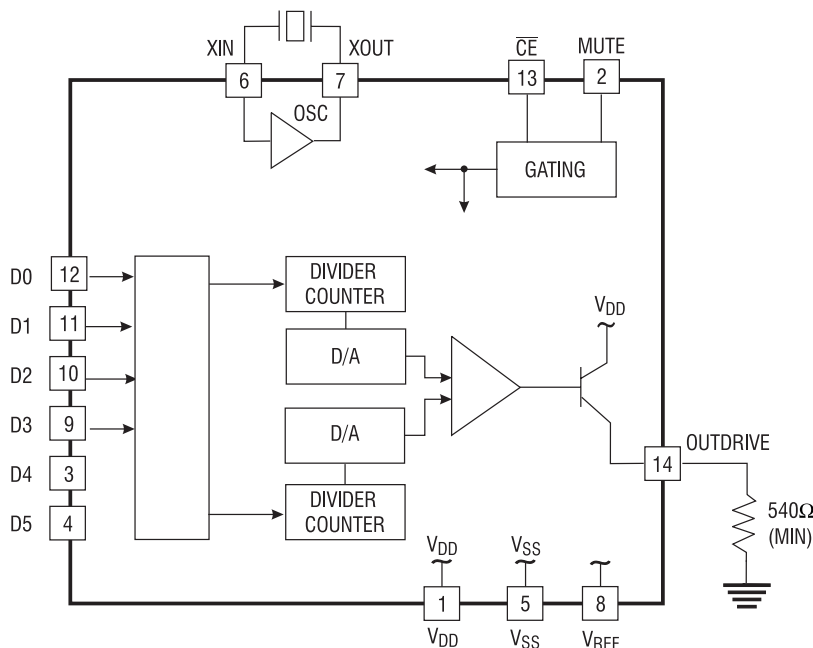

**Absolute Maximum Ratings**

Storage Temperature	-55 to 125°C
Operating Ambient Temperature	-25 to 70°C
V _{DD}	7.0V
Any Input Voltage	V _{SS} - 0.6 to V _{DD} + 0.6V

Note:

- Exceeding these ratings may permanently damage the M-993.

Absolute Maximum Ratings are stress ratings. Stresses in excess of these ratings can cause permanent damage to the device. Functional operation of the device at these or any other conditions beyond those indicated in the operational sections of this data sheet is not implied. Exposure of the device to the absolute maximum ratings for an extended period may degrade the device and effect its reliability.

Specifications

Parameter		Min	Typ	Max	Units	Notes
Power Supply and Reference	V _{DD}	4.75	-	5.25	V	1
	Current Drain, I _{DD}	-	2.0/4.0	-	mA	8
	V _{REF} PIN: Voltage	48% of V _{DD}	-	52% of V _{DD}	%	-
	Internal Resistance from V _{REF} to V _{DD} , V _{SS}	3.25	-	6.75	kΩ	-
Oscillator	Frequency Deviation	-0.01	-	+0.01	%	7
	External CLock: (X _{OUT} open)					
	V _{IL}	0	-	0.2	V	-
	V _{IH}	V _{DD} - 0.2	-	V _{DD}	V	-
	Duty Cycle	40	-	60	%	-
	X _{IN} , X _{OUT} Loading:					
Capacitance	-	-	10	pF	9	
Resistance	20	-	-	MΩ	-	
Tone Output	Frequency Deviation	-1.5	-	1.5	%	-
	Level	110	-	180	mV	2
	Distorting Components	-35	-	-	dB	2, 3
	Idle	-	-	-60	dBm	4
	OUTDRIVE Envelope Rise Time	-	-	4	ms	5
Control	DX, \overline{CE} Pins:					
	V _{IL}	-	-	0.5	V	6
	V _{IH}	2.5	-	-	V	-
	Mute Pins:					
	VOL (ISINK = -100 μA)	-	-	1.5	V	-
VOH (ISOURCE = 100 μA)	V _{DD} - 1.5	-	-	V	-	
Timing	Data Setup (t _{DSRT})	200	-	-	ns	10
	Data Hold (t _{DH})	10	-	-	ns	-
	Chip Enable Fall (t _{PL})	-	-	90	ns	-
	Tone On Delay (t _{TO})	5	-	-	ms	-
	Tone Off Delay (t _{TD})	5	-	-	ms	-
	Mute Delay from Outdrive (t _{MO})	-	-	200	ns	-

Unless otherwise noted, V_{DD} - V_{SS} = 5 VDC, Ta = 25° C

Notes:

- All DC voltages are referenced to V_{SS}.
- Vrms per tone, 540W load.
- Any one frequency relative to the lowest level output tone (f < 4000 Hz).
- 0 dBm = 0.775 Vrms.
- To 90% maximum amplitude.
- For all supply voltages in the operating range.
- At XOUT pin as compared to 3.579545 MHz.
- OUTDRIVE with load > 5 KW/OUTDRIVE with 540W load.
- Crystal oscillator active.
- Measured 90% to 10%.

Pin Function

Pin	Function
$\overline{\text{CE}}$	Latches data and enables output (active low input).
D0 - D3	Data input pins. (See Data/Tone Selection.)
D4-D5	Leave open.
MUTE	Output indicates that a signal is being generated at OUTDRIVE.
OUTDRIVE	Linear buffered tone output.
V_{DD}	Most positive power supply input pin.
V_{REF}	Internally generated mid-power supply voltage (output).
V_{SS}	Most negative power supply input pin.
X_{IN}	Crystal oscillator or digital clock input.
X_{OUT}	Crystal oscillator output.

Data/Tone Selection

D3	D2	D1	D0	Frequency (Hz)		Use
				1	2	
0	0	0	0	1100	1700	Key Pulse (KP)
0	0	0	1	700	900	Digit 1
0	0	1	0	700	1100	Digit 2
0	0	1	1	900	1100	Digit 3
0	1	0	0	700	1300	Digit 4
0	1	0	1	900	1300	Digit 5
0	1	1	0	1100	1300	Digit 6
0	1	1	1	700	1500	Digit 7
1	0	0	0	900	1500	Digit 8
1	0	0	1	1100	1500	Digit 9
1	0	1	0	1300	1500	Digit 0
1	0	1	1	1500	1700	ST
1	1	0	0	900	1700	ST1
1	1	0	1	1300	1700	ST2
1	1	1	0	700	1700	ST3

Power-On Reset Circuit

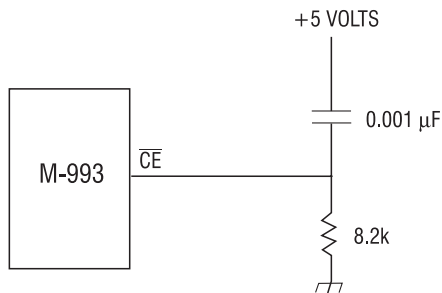

A typical control sequence for the M-993 is: (1) set data lines Selection for data settings for a particular tone pair output).to desired frequency selection, (2) wait for data lines to settle, (3) drive the chip enable (CE) low, (4) maintain CE low for desired tone duration (Note: data lines may be changed after data hold time), and (5) return CE to a logic high.

In a bus-oriented system, noise on the data lines may propagate through the device and appear at the output. To safeguard against this, use an external latch to clock the data into the device. In addition, it is good

practice to bypass the V_{REF} pin to ground with a small capacitor ($\sim 0.01\text{mF}$) to reduce power supply noise. The designer should be aware of device timing requirements and design accordingly. Beware of hard-wiring the data input pins for dedicated tone generation. An RC network like that shown in Power-On Reset Circuit should be used to momentarily reset the device immediately following a power-up to ensure reliable operation.

Timing Diagram

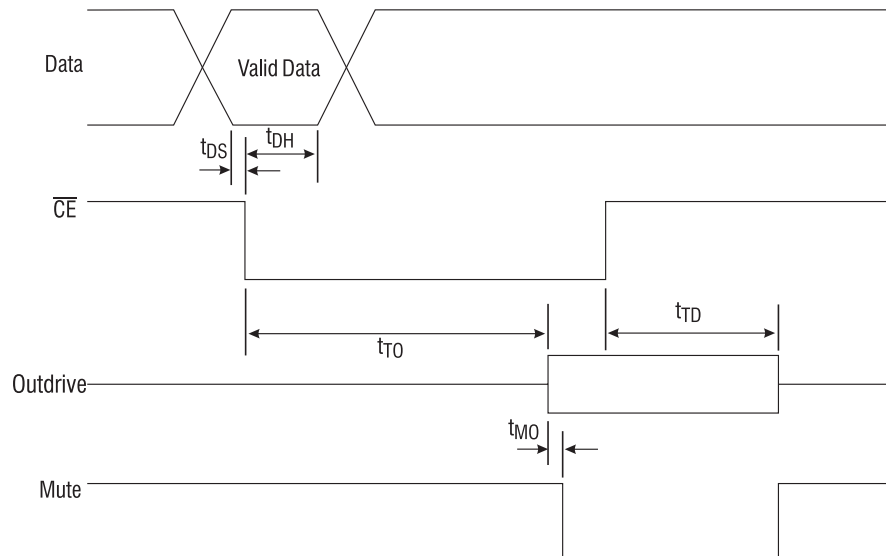

Expanded Timing Diagram

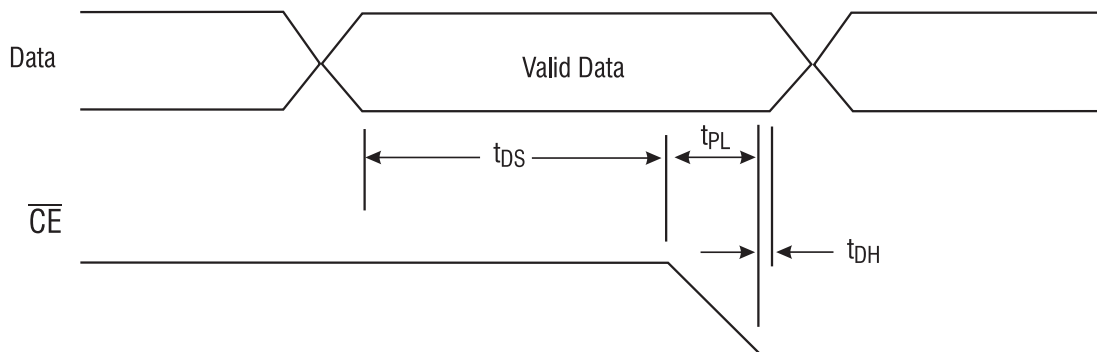

Typical Application

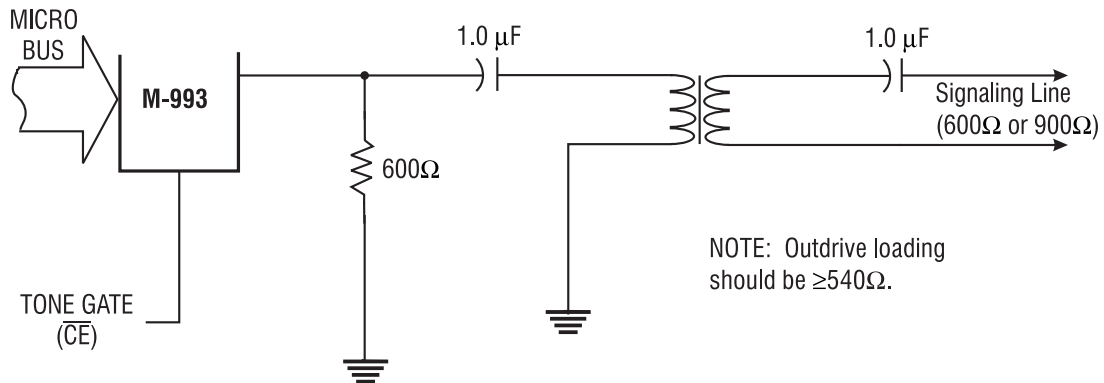

Mechanical Dimensions

14-Pin DIP

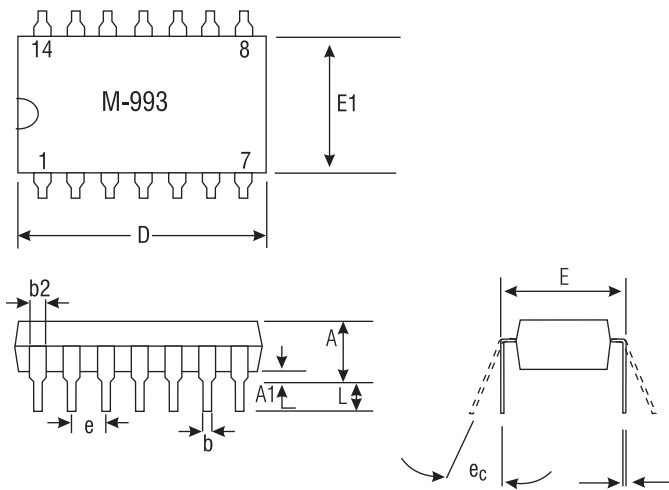

	Tolerances			
	Inches		Metric (mm)	
	Min	Max	Min	Max
A	-	.210	-	5.33
A1	.015	-	.38	-
b	.014	.022	.36	.56
b2	.045	.070	1.1	1.8
C	.008	.014	.20	.36
D	.735	.775	18.7	19.7
E	.300	.325	7.6	8.3
E1	.240	.280	6.1	7.1
e	.100 BSC		2.54 BSC	
ec	0°	15°	0°	15°
L	.115	.150	2.9	4.1

Drawing not to scale.
Does not reflect actual part marking.

Dimensions
mm
(inches)



CLARE LOCATIONS

Clare Headquarters
78 Cherry Hill Drive
Beverly, MA 01915
Tel: 1-978-524-6700
Fax: 1-978-524-4900
Toll Free: 1-800-27-CLARE

Clare Switch Division
4315 N. Earth City Expressway
Earth City, MO 63045
Tel: 1-314-770-1832
Fax: 1-314-770-1812

Clare Micronix Division
145 Columbia
Aliso Viejo, CA 92656-1490
Tel: 1-949-831-4622
Fax: 1-949-831-4628

SALES OFFICES

AMERICAS

Americas Headquarters

Clare
78 Cherry Hill Drive
Beverly, MA 01915
Tel: 1-978-524-6700
Fax: 1-978-524-4900
Toll Free: 1-800-27-CLARE

Eastern Region

Clare
603 Apache Court
Mahwah, NJ 07430
Tel: 1-201-236-0101
Fax: 1-201-236-8685
Toll Free: 1-800-27-CLARE

Central Region

Clare Canada Ltd.
3425 Harvester Road, Suite 202
Burlington, Ontario L7N 3N1
Tel: 1-905-333-9066
Fax: 1-905-333-1824

Western Region

Clare
1852 West 11th Street, #348
Tracy, CA 95376
Tel: 1-209-832-4367
Fax: 1-209-832-4732
Toll Free: 1-800-27-CLARE

Canada

Clare Canada Ltd.
3425 Harvester Road, Suite 202
Burlington, Ontario L7N 3N1
Tel: 1-905-333-9066
Fax: 1-905-333-1824

EUROPE

European Headquarters

CP Clare nv
Bampsplaan 17
B-3500 Hasselt (Belgium)
Tel: 32-11-300868
Fax: 32-11-300890

France

Clare France Sales
Lead Rep
99 route de Versailles
91160 Champlan
France
Tel: 33 1 69 79 93 50
Fax: 33 1 69 79 93 59

Germany

Clare Germany Sales
ActiveComp Electronic GmbH
Mitterstrasse 12
85077 Manching
Germany
Tel: 49 8459 3214 10
Fax: 49 8459 3214 29

Italy

C.L.A.R.E.s.a.s.
Via C. Colombo 10/A
I-20066 Melzo (Milano)
Tel: 39-02-95737160
Fax: 39-02-95738829

Sweden

Clare Sales
Comptronic AB
Box 167
S-16329 Spånga
Tel: 46-862-10370
Fax: 46-862-10371

United Kingdom

Clare UK Sales
Marco Polo House
Cook Way
Bindon Road
Taunton
UK-Somerset TA2 6BG
Tel: 44-1-823 352541
Fax: 44-1-823 352797

ASIA/PACIFIC

Asian Headquarters

Clare
Room N1016, Chia-Hsin, Bldg II,
10F, No. 96, Sec. 2
Chung Shan North Road
Taipei, Taiwan R.O.C.
Tel: 886-2-2523-6368
Fax: 886-2-2523-6369

<http://www.clare.com>

Clare, Inc. makes no representations or warranties with respect to the accuracy or completeness of the contents of this publication and reserves the right to make changes to specifications and product descriptions at any time without notice. Neither circuit patent licenses nor indemnity are expressed or implied. Except as set forth in Clare's Standard Terms and Conditions of Sale, Clare, Inc. assumes no liability whatsoever, and disclaims any express or implied warranty, relating to its products including, but not limited to, the implied warranty of merchantability, fitness for a particular purpose, or infringement of any intellectual property right.

The products described in this document are not designed, intended, authorized or warranted for use as components in systems intended for surgical implant into the body, or in other applications intended to support or sustain life, or where malfunction of Clare's product may result in direct physical harm, injury, or death to a person or severe property or environmental damage. Clare, Inc. reserves the right to discontinue or make changes to its products at any time without notice.

Specification: DS-M-993-R1
©Copyright 2001, Clare, Inc.
All rights reserved. Printed in USA.
7/18/01