

- 1N4153UR-1 AVAILABLE IN JAN, JANTX, AND JANTXV  
PER MIL-PRF-19500/337
- SWITCHING DIODE
- HERMETICALLY SEALED
- METALLURGICALLY BONDED
- DOUBLE PLUG CONSTRUCTION

**1N4153UR-1  
CDLL4153**

**MAXIMUM RATINGS**

Junction Temperature: -65°C to +175°C  
 Storage Temperature: -65°C to +175°C  
 Operating Current: 150 mA @  $T_A = +25^\circ\text{C}$   
 Derating: 1.0 mA dc/°C Above  $T_A = +25^\circ\text{C}$   
 Forward Surge Current: 2A (pk), (tp = 1µs); 0.25A (pk), (tp = 1s)

**ELECTRICAL CHARACTERISTICS @ 25°C, unless otherwise specified.**

Type	$V_{BR}$	$V_{RWM}$	$I_{R1}$	$I_{R2}$	$C$	$t_{rr}$
	$I_R = 5 \mu\text{A}$		$V_R = 50 \text{ V dc}$ $T_A = 25^\circ\text{C}$	$V_R = 50 \text{ V dc}$ $T_A = 150^\circ\text{C}$	$V_R = 0; f = 1 \text{ Mhz};$	
	V dc	V (pk)	nA dc	µA dc	pF	ns
4153UR-1 CDLL4153	75 75	50 50	50 50	50 50	2.0 2.0	4 4

**FORWARD VOLTAGE LIMITS – ALL TYPES**

Limits	$V_{F1}$	$V_{F2}$	$V_{F3}$	$V_{F4}$	$V_{F5}$	$V_{F6}$
	$I_F = 100 \mu\text{A dc}$	$I_F = 250 \mu\text{A dc}$	$I_F = 1 \text{ mA dc}$	$I_F = 2 \text{ mA dc}$	$I_F = 10 \text{ mA dc}$	$I_F = 20 \text{ mA dc}$
	V dc	V dc	V dc	V dc	V dc	V dc
minimum	0.49	0.53	0.59	0.62	0.70	0.74
maximum	0.55	0.59	0.67	0.70	0.81	0.88

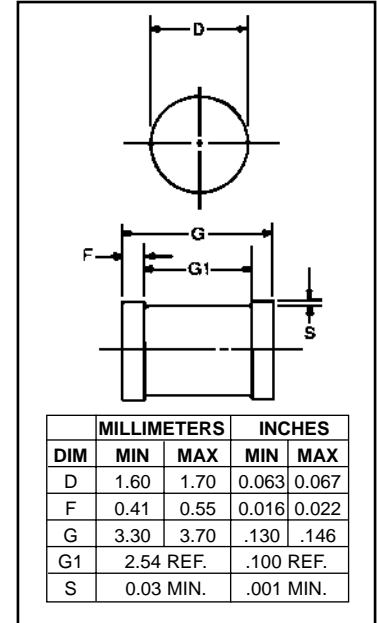

**FIGURE 1**

**DESIGN DATA**

**CASE:** DO-213AA, Hermetically sealed glass case. (MELF, SOD-80; LL34)

**LEAD FINISH:** Tin / Lead

**THERMAL RESISTANCE ( $R_{\theta JEC}$ ):**  
100 °C/W maximum at L = 0

**THERMAL IMPEDANCE: ( $Z_{\theta JX}$ ):** 70 °C/W maximum

**POLARITY:** Cathode end is banded.

**MOUNTING SURFACE SELECTION:**  
The Axial Coefficient of Expansion (COE) of this Device is Approximately +6PPM/°C. The COE of the Mounting Surface System Should Be Selected To Provide A Suitable Match With This Device.



**COMPENSATED DEVICES INCORPORATED**

22 COREY STREET, MELROSE, MASSACHUSETTS 02176  
 PHONE (781) 665-1071 FAX (781) 665-7379  
 WEBSITE: <http://www.cdi-diodes.com> E-mail: [mail@cdi-diodes.com](mailto:mail@cdi-diodes.com)

# IN4153UR-1 and CDLL4153

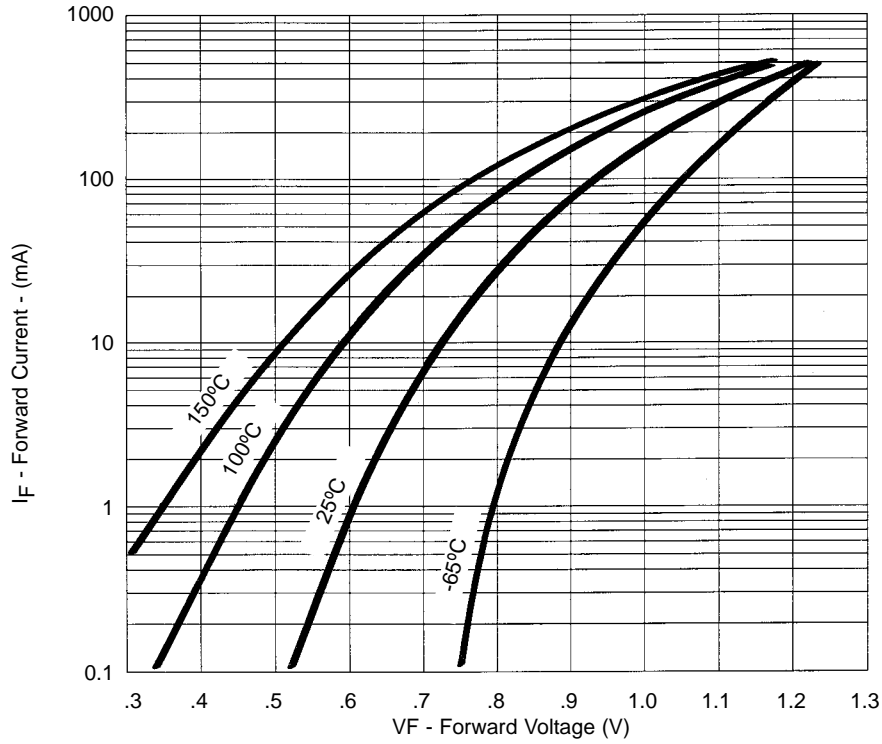

**FIGURE 2**  
Typical Forward Current  
vs Forward Voltage

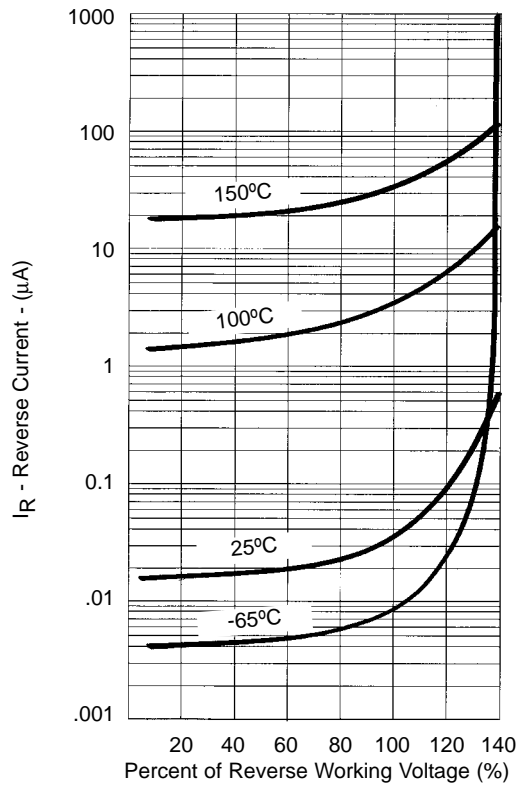

**FIGURE 3**  
Typical Reverse Current  
vs Reverse Voltage

**NOTE :** All temperatures shown on graphs are junction temperatures