

## 1. MECHANICAL DATA

(1) Product No.	<b>AGM3224Y</b>
(2) Module Size	76.8 (W)mm x 103.7 (H)mm x 6.5(D)mm
(3) Dot Size	0.234 (W)mm x 0.068 (H)mm
(4) Dot Pitch	0.249 (W)mm x 0.083 (H)mm
(5) Number of Dots	240 (W) x (320 x RGB (H)) Dots
(6) Duty	1/240
(7) LCD Display Mode	FSTN: Color STN Module REAR POLARIZER: Color Transmissive Type
(8) Viewing Direction	6 O'clock
(9) Backlight	CCFL
(10) Controller	Excluded
(11) DC/DC Converter	Excluded
(12) Weight	65.0 g(approx.)

Revised: August 27, 2001

## 2. ABSOLUTE MAXIMUM RATINGS

### (1) ELECTRICAL ABSOLUTE RATINGS

VSS=0V

ITEM	SYMBOL	MIN	MAX	UNIT	COMMENT
Power Supply for Logic	VDD-VSS	-0.3	7.0	V	
Power Supply for LCD Drive	VEE-VSS	0	42.0	V	
Input Voltage	VI	-0.3	VDD+0.3	V	
Static Electricity	-	-	-	-	Note 1

### (2) ENVIRONMENTAL ABSOLUTE MAXIMUM RATINGS

ITEM	NORMAL TEMP.			
	OPERATING		STORAGE	
	MIN.	MAX.	MIN.	MAX.
Ambient Temperature	0	50	-20	60
Humidity (Without Condensation)	Note 2,4		Note 3,4	

Note 1 LCM should be grounded during handling.

Note 2 Ta  $\leq$  50°C : 85%RH max  
 Ta > 50°C : Absolute humidity must be lower  
 than the humidity of 85%RH at 50°C

Note 3 Ta at -20°C will be < 48 hrs, at 60°C will be < 120 hrs

Note 4 Background will color change slightly depending on ambient temperature.  
 This phenomenon is reversible.

## 3. ELECTRICAL CHARACTERISTICS

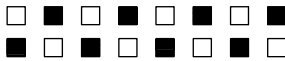
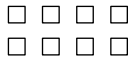
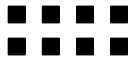
ITEM		SYMBOL	CONDITION		MIN.	TYP.	MAX.	UNIT
Logic Circuit Power Supply		VDD-VSS	Ta= 25°C		3.0	3.3	3.6	V
					4.5	5.0	5.5	
Input Voltage		VIH	H level		0.8VDD	-	VDD	V
		VIL	L level		0	-	0.2VDD	V
Recommended LCD Driving Voltage (Normal Temp. LCM)		VEE-VSS	Duty=1/240 Bias=1/14 VDD=5.0V	0°C	24.9	25.2	25.5	V
				25°C	23.7	24.0	24.3	
				50°C	22.7	23.0	23.3	
Supply Current for Logic		IDD	VDD-VSS = 5.0V VEE-VSS = 24.0V Ta= 25°C		-	2.0	3.5	mA
Supply Current for LCD		IEE	PATTERN: 		-	12.0	18.0	mA
LCM	Surface Luminance	L	VDD-VSS=5.0V VEE-VSS=24.0V Ta= 25°C IL=2.5mArms	PATTERN: (Dots All On of White Color) 	-	89.0	-	cd/m <sup>2</sup>
				PATTERN: (Dots All Off) 	-	7.3	-	cd/m <sup>2</sup>

### CCFL

PARAMETER	SYMBOL	MIN.	TYP.	MAX.	UNIT	REMARK
Lamp Voltage	VL	-	300	-	Vrms	IL = 2.5mArms
Lamp current	IL	1.5	2.5	3	mArms	(*1)
Lamp power consumption	PL	0.5	0.8	1	W	(*2)
Lamp frequency	FL	30	40	50	KHz	
Lamp life time	LL	-	20000	-	hrs	

(\*1) It is recommended that IL be not more than 2.5 mArms so that heat radiation of CCFT backlight may least affect the display quality .

(\*2) Power consumption excludes inverter .

## 4. OPTICAL CHARACTERISTICS

### 4-1 Optical Char. of Normal Temp. Mode

AT Vop

ITEM MODE		Cr(Contrast Ratio)						$\theta$ (Viewing Angle)		$\phi$ (Viewing Angle)	
		0°C		25°C		50°C		25°C		25°C	
		MIN.	TYP.	MIN.	TYP.	MIN.	TYP.	MIN.	TYP.	MIN.	TYP.
T	G	-	29	-	20	-	5.5	-	100	-	±45
NOTE		NOTE 6						NOTE 5			

note:

T: TRANSMISSIVE  
G: NORMALLY BLACK 6 O'CLOCK

AT  $\phi=0^\circ$   $\theta=0^\circ$

ITEM	SYMBOL	CONDITION	MIN.	TYP.	MAX.	UNIT	NOTE
Response Time (rise)	Tr	0℃	-	600	-	ms	NOTE 2
		25℃	-	250	-		
		50℃	-	90	-		
Response Time (fall)	Tf	0℃	-	300	-	ms	NOTE 2
		25℃	-	90	-		
		50℃	-	60	-		

## 4-2 Color of CIE Coordinate

Ta = 25°C

ITEM		SYMBOL	CONDITION	VALUE	BRIGHTNESS (cd/m <sup>2</sup> )
Color of CIE Coordinate	Red	X	$\phi=0^\circ, \theta=0^\circ$	0.49	22.9
		y		0.34	
	Green	X		0.29	61.4
		y		0.53	
	Blue	X		0.17	21.4
		y		0.18	
	White	X		0.29	89.0
		y		0.35	

Tolerance :  $\pm 0.05$

Fig.1

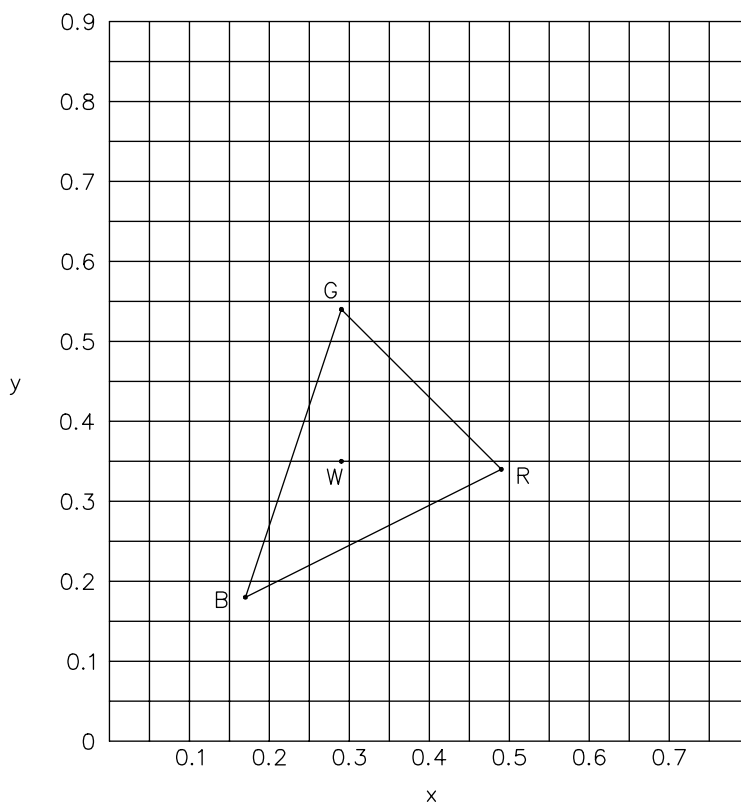

(NOTE 1)

Definition of Operation Voltage( $V_{op}$ )

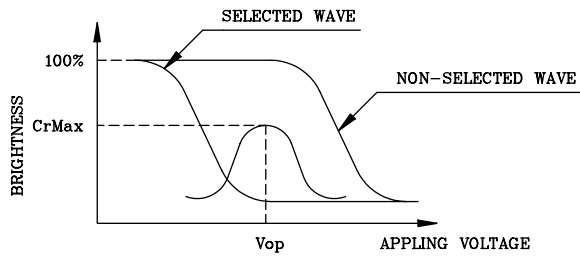

(positive type)

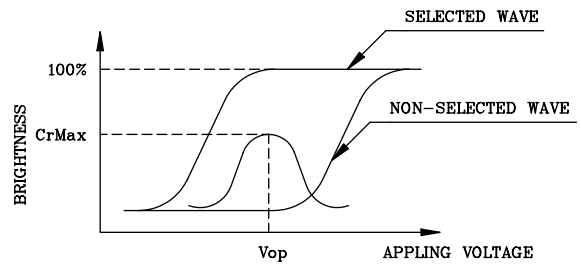

(negative type)

\*Conditions

Viewing Angle : 0  
 Frame Frequency : 70Hz  
 Applying Waveform : I/N duty 1/a bias

(NOTE 2)

Definition of Response Time( $T_r, T_f$ )

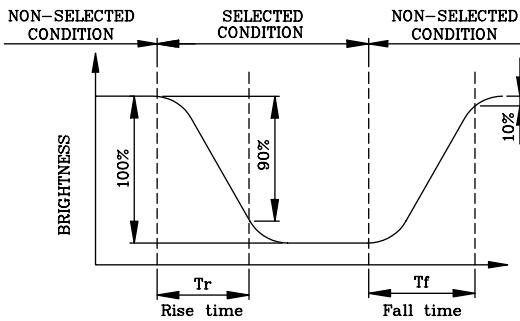

(positive type)

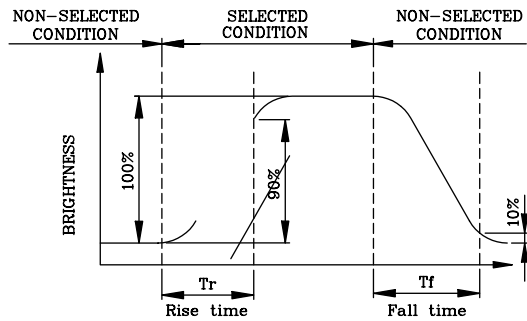

(negative type)

\*Conditions

Operating Voltage :  $V_{op}$   
 Viewing Angle ( $\theta, \theta$ ) : (0,0)  
 Frame Frequency : 70Hz  
 Applying Waveform : I/N duty 1/a bias

(NOTE 3)

Description of Measuring Equipment and Driving Waveforms

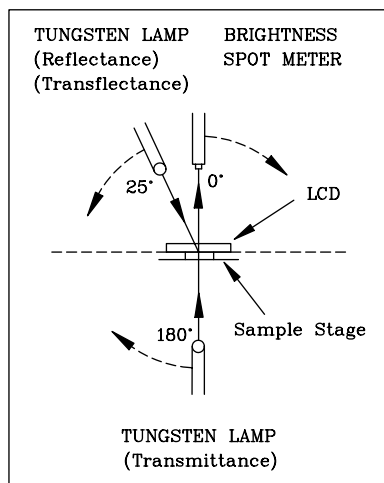

CONST.  
TEMP.  
CHAMBER

Multiplex Driving ( I/N duty 1/a bias )

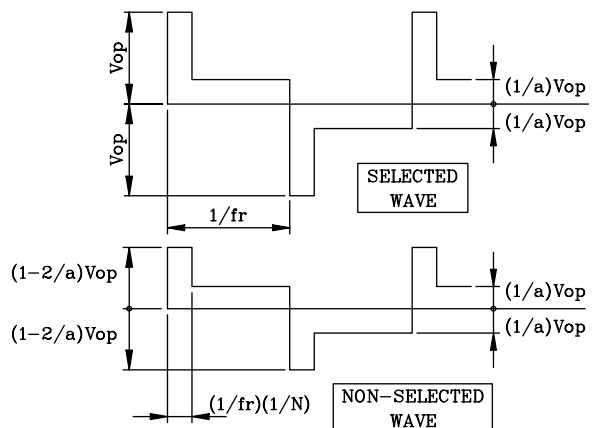

(NOTE 4)

Definition of Viewing Direction

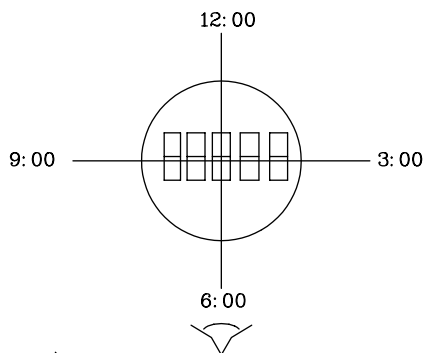

(NOTE 5)

Definition of Viewing Angle

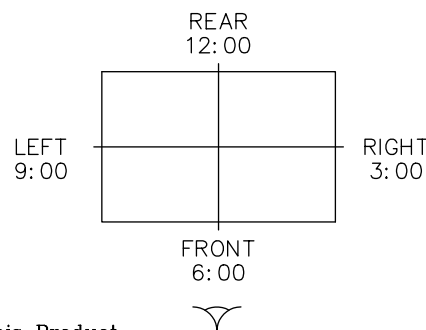
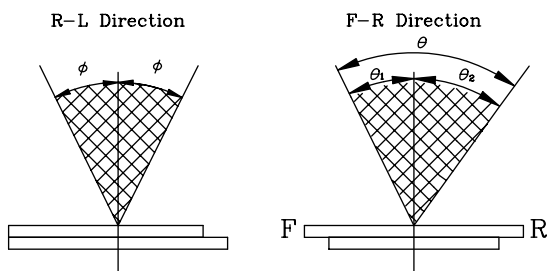

\*For This Product  
The Viewing Direction Is 6 O'clock  
So  $\theta_1 > \theta_2$

$$\theta = \theta_1 + \theta_2$$

\*Conditions

Operating Voltage :  $V_{op}$   
Frame Frequency : 70Hz  
Applying Waveform : 1/N duty 1/a bias  
Contrast Ratio : larger than 2

(NOTE 6)

Definition of Contrast Ratio (Cr)

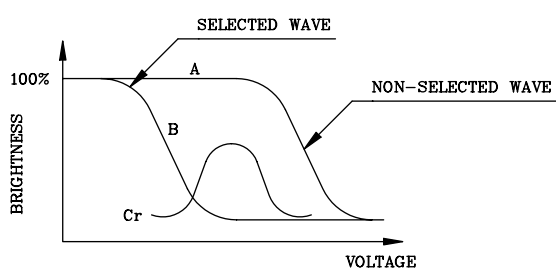

(positive type)

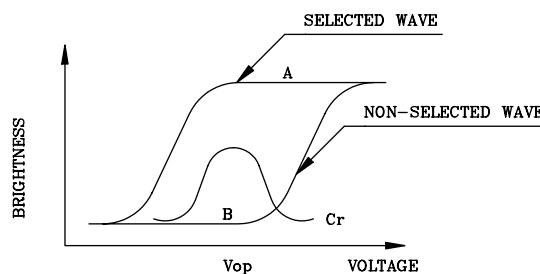

(negative type)

$$\text{Contrast Ratio : } Cr = A/B$$

\*Conditions

Viewing Angle : 0  
Frame Frequency : 70Hz  
Applying Waveform : 1/N duty 1/a bias

## 5. BLOCK DIAGRAM

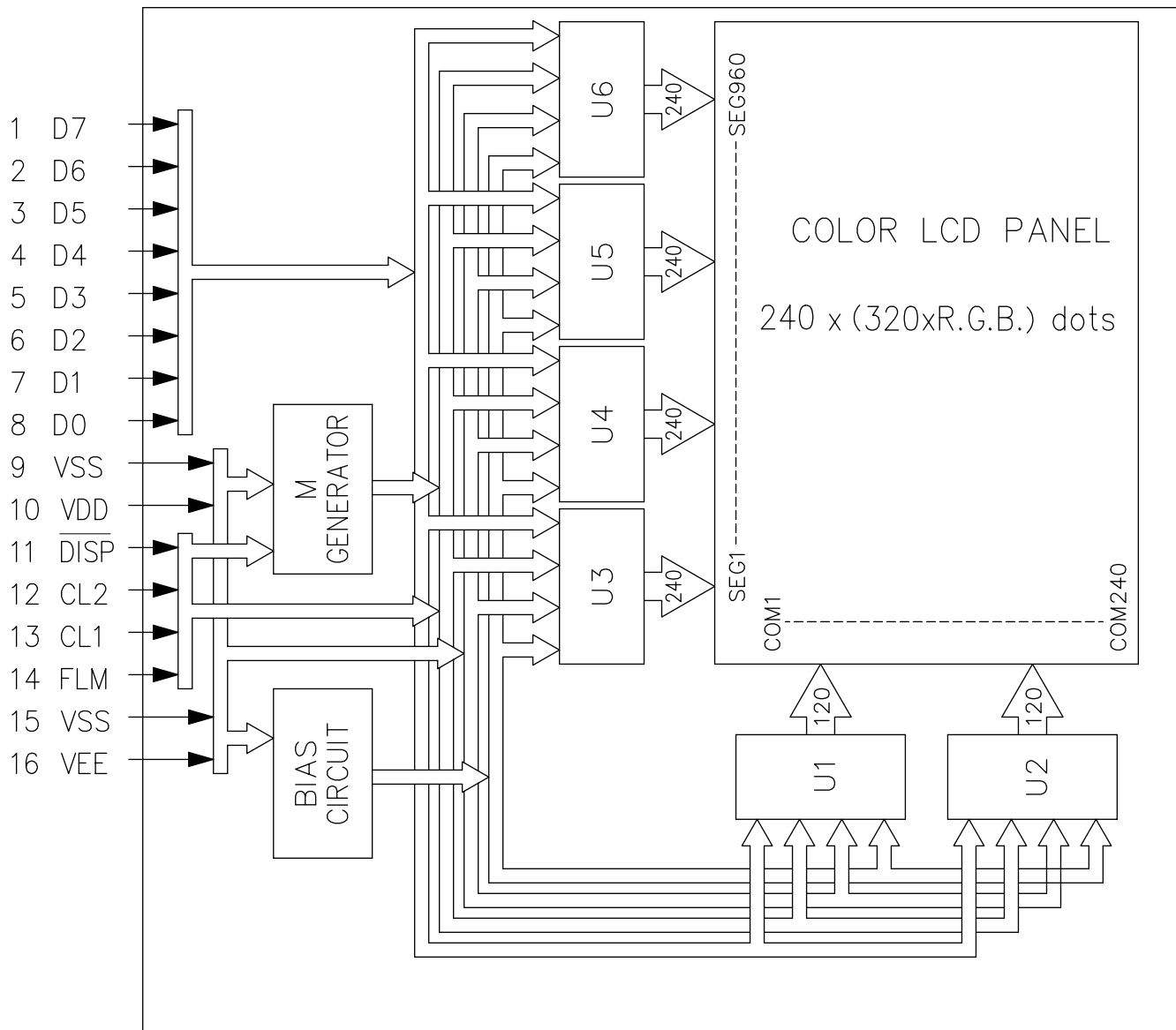

### CCFL

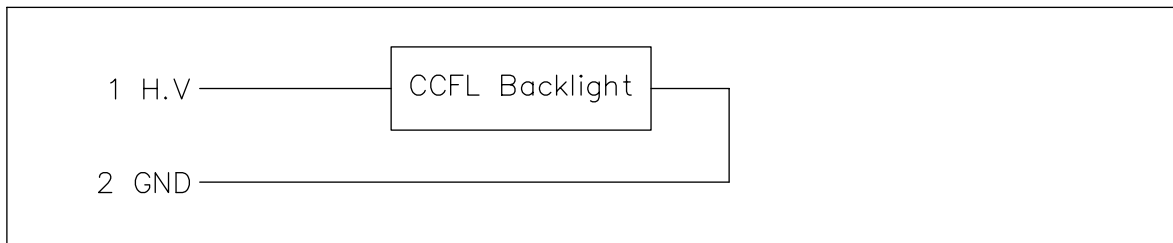



## 6. INTERNAL PIN CONNECTION

### LCD

Pin No.	Symbol	Level	Function
1	D7	H/L	Display Data
2	D6	H/L	Display Data
3	D5	H/L	Display Data
4	D4	H/L	Display Data
5	D3	H/L	Display Data
6	D2	H/L	Display Data
7	D1	H/L	Display Data
8	D0	H/L	Display Data
9	VSS	–	GND
10	VDD	–	Power Supply for Logic
11	$\overline{\text{DISP}}$	H/L	Display Control Signal, H :Display on L :Display off
12	CL2	H/L	Data input clock
13	CL1	H/L	Input data latch signal
14	FLM	H/L	Scan start-up signal
15	VSS	H/L	Power Supply (0V,GND)
16	VEE	–	Power Supply for LCD

### CCFL

Pin No.	Symbol	Level	Function
1	H.V	–	Power Supply for CFL
2	GND	–	CFL GND

### LCD INTERFACE CONNECTOR

FH12-16S-0.5SV (HIROSE)/Suitable FFC :pitch 0.5mm ,width 8.5mm

### CCFL CONNECTOR :

BHSR -02VS-1 (JST)/Suitable Connector :SM02B-BHSS-1-TB (JST)

## 7. POWER SUPPLY

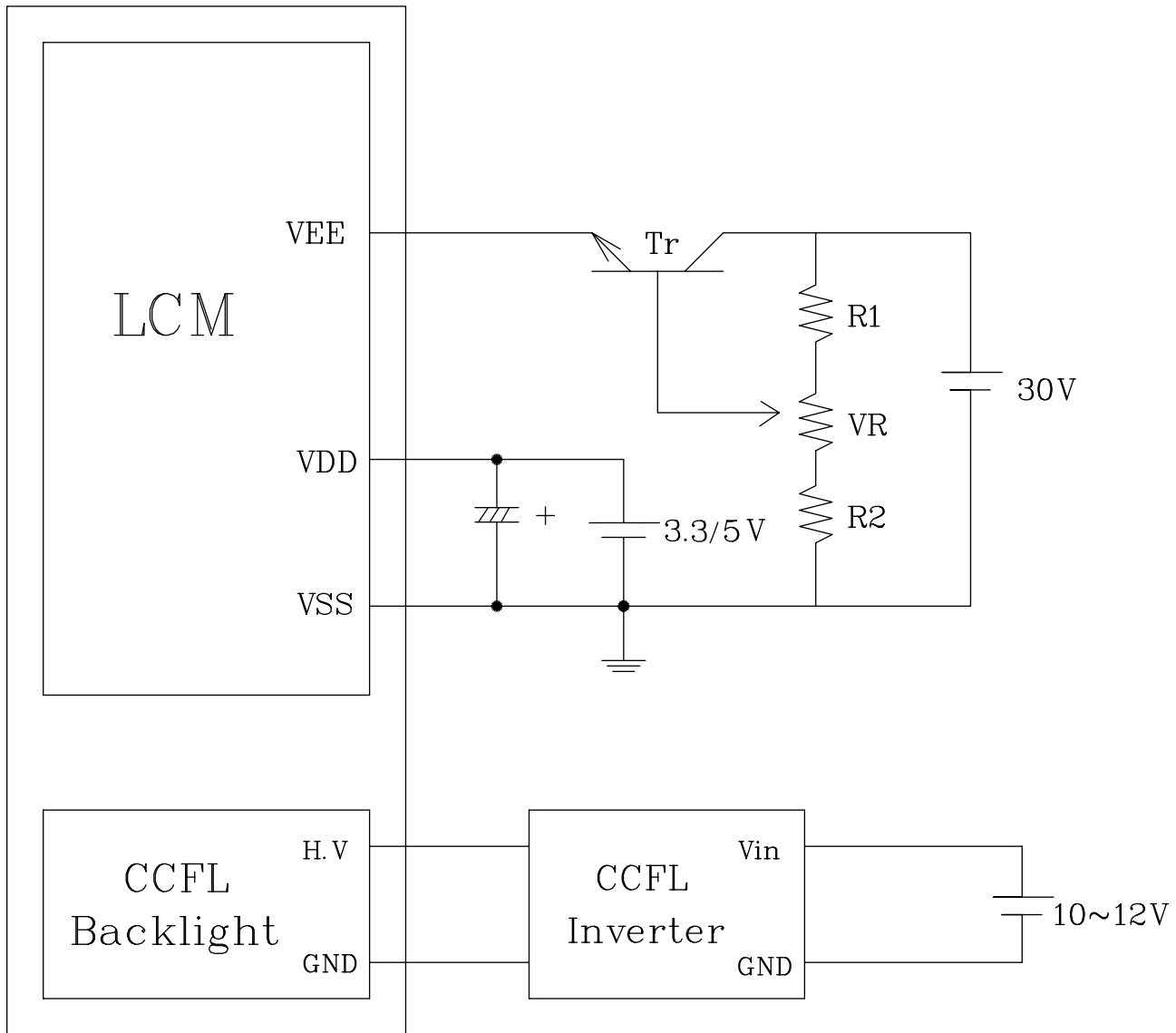

1.  $R1 + R2 + VR = 10 \sim 20K \Omega$
2. RECOMMENDED CCFL INVERTER :  
COTEK INV-B1

## 8. TIMING CHARACTERISTICS

### 8-1 INTERFACE TIMING

VDD=5.0V ± 10%

Parameter	SYMBOL	MIN.	MAX.	UNIT
CLOCK CYCLE TIME	$t_{cyc}$	50	—	ns
CL2 HIGH LEVEL WIDTH	$t_{cwh2}$	15	—	ns
CL2 LOW LEVEL WIDTH	$t_{cwl2}$	15	—	ns
CL1 HIGH LEVEL WIDTH	$t_{cwh1}$	25	—	ns
CL2 SETUP TIME	$t_{scl}$	100	—	ns
CL2 HOLD TIME	$t_{hcl}$	100	—	ns
CL2 - CL1 RISE TIME	$t_{ld}$	5	—	ns
CLOCK RISE / FALL TIME	$t_{ct}$	—	—	ns
DATA SETUP TIME	$t_{ds}$	10	50	ns
DATA HOLD TIME	$t_{dh}$	15	—	ns
FLM SETUP TIME	$t_{fs}$	30	—	ns
DATA HOLD TIME	$t_{fh}$	50	—	$\mu s$
FRAME FREQUENCY	$t_{flm}$	60	—	ns

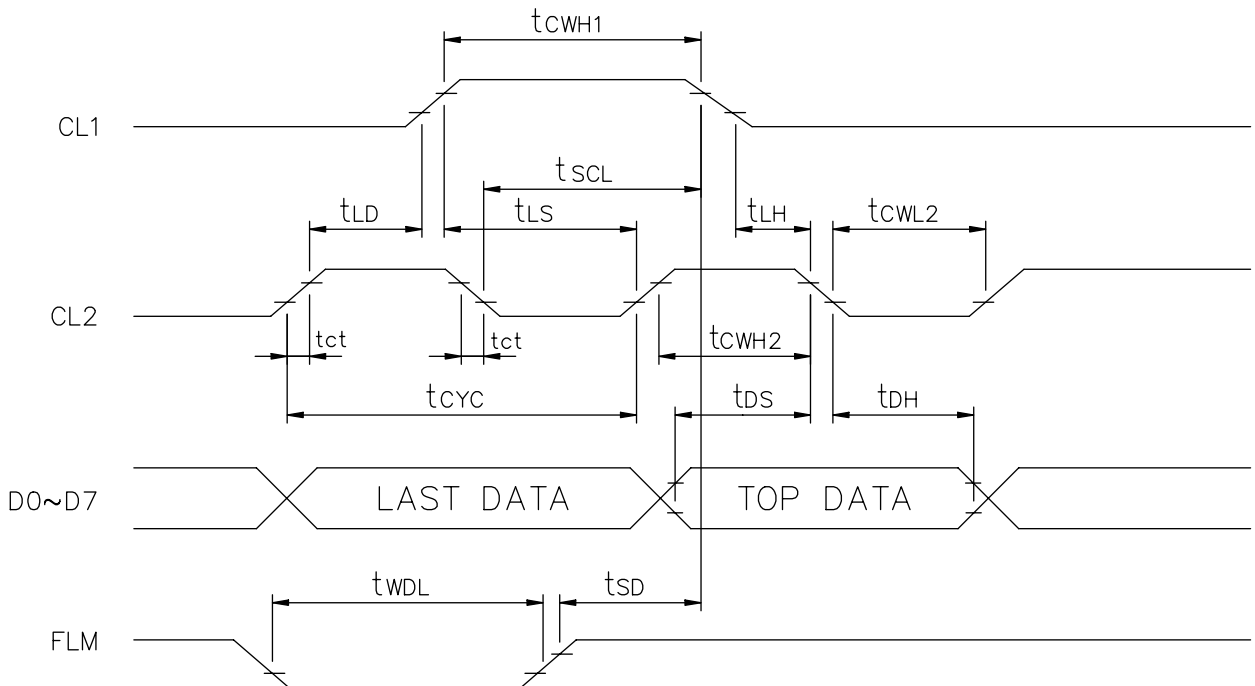

## 8-2 TIMING CHART OF INPUT SIGNAL

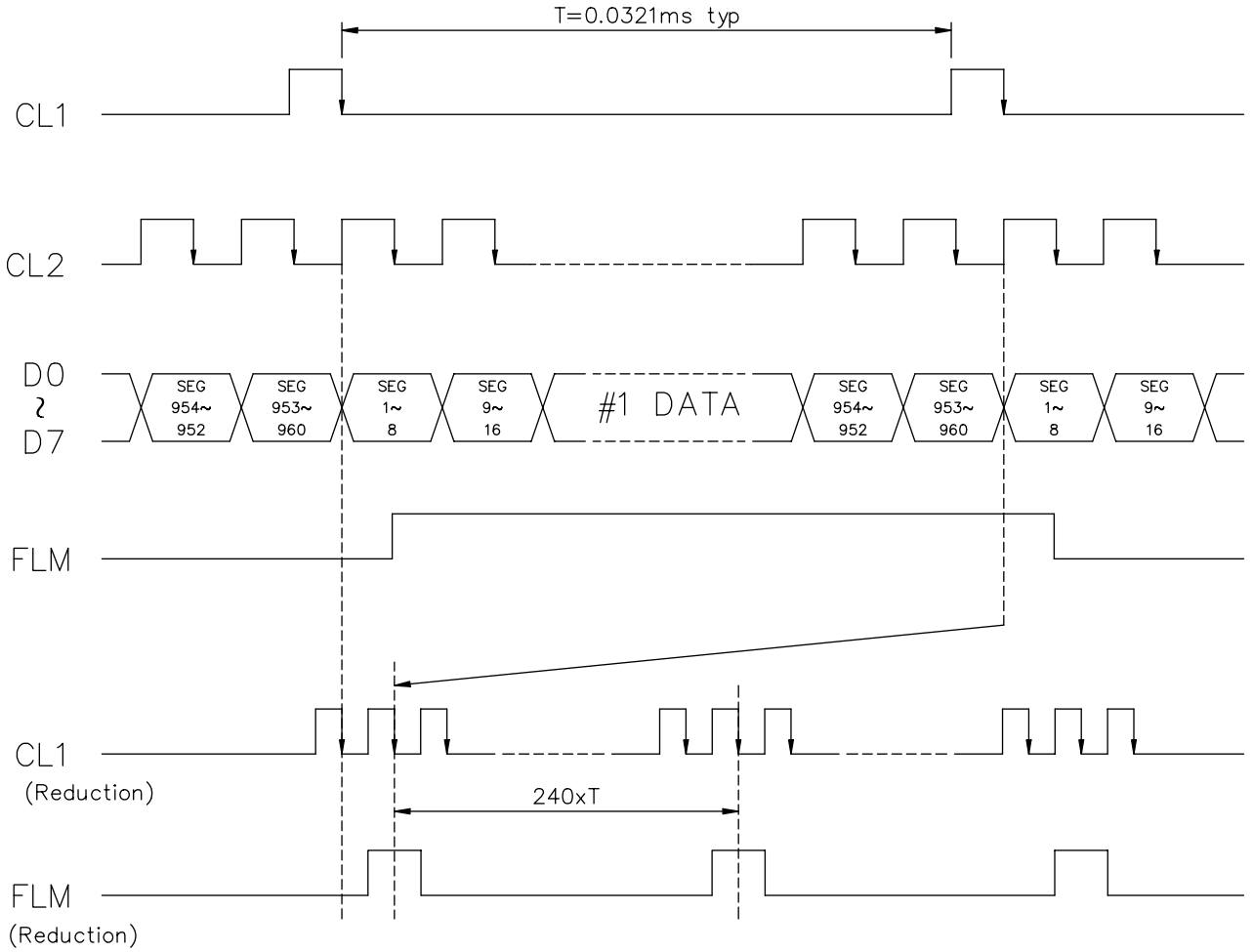

## 8-3 POWER ON/OFF TIMING

### ON SEQUENCE

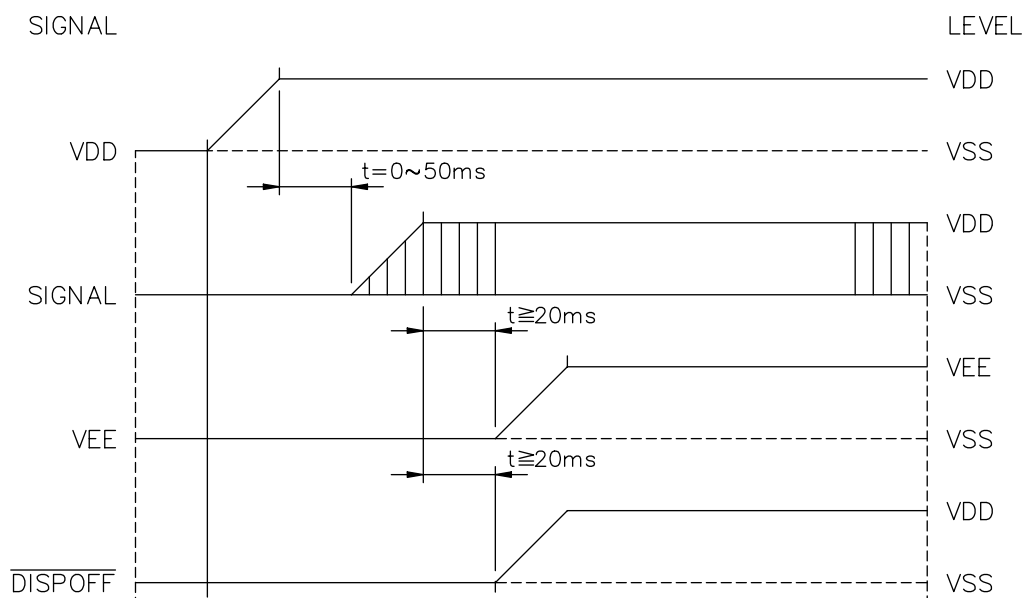

### OFF SEQUENCE

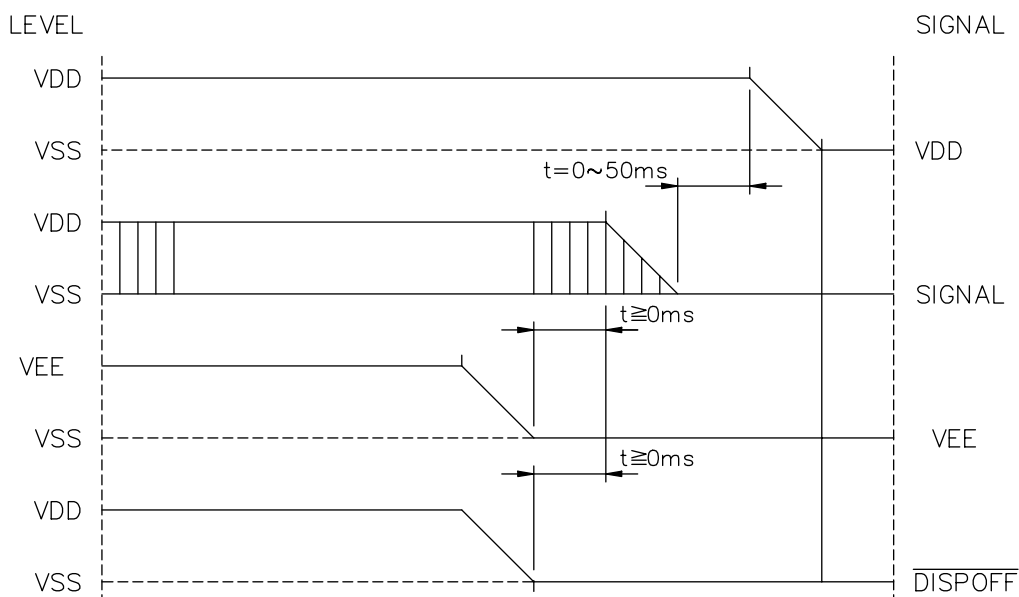

Please maintain the above sequence when turning on and off the power supply of the module. If  $\overline{\text{DISPOFF}}$  is supplied to the module while internal alternate signal for LCD driving(M) is unstable, DC component will be supplied to the LCD panel. This may cause damage to the LCD module.

## 8-4 DISPLAY PATTERN

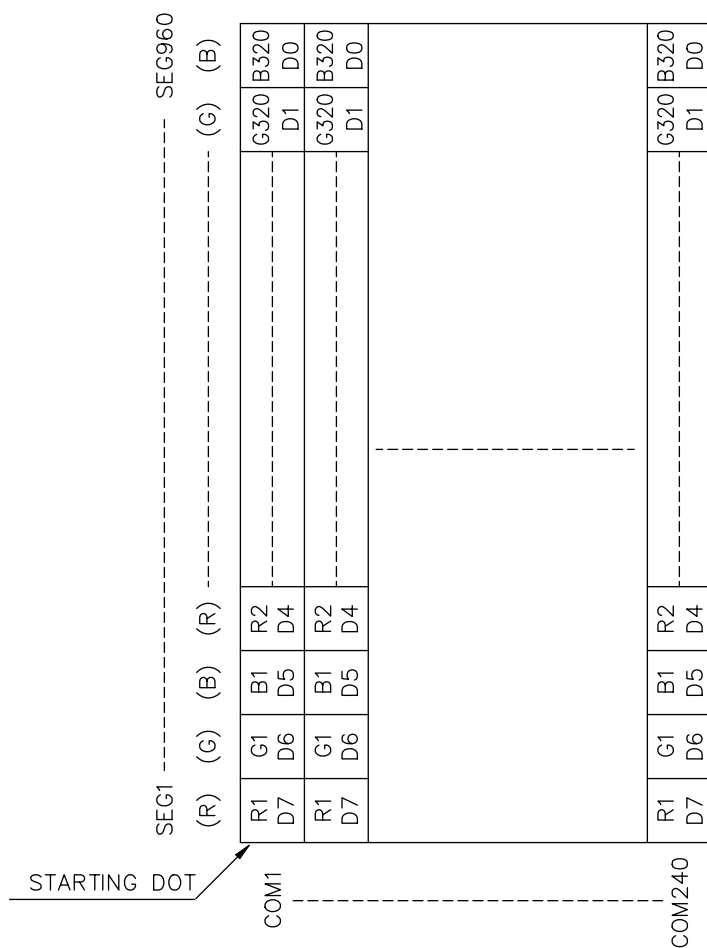

D0~D7 are 8 bits transmitted data, where D0 is LSB and D7 is MSB.

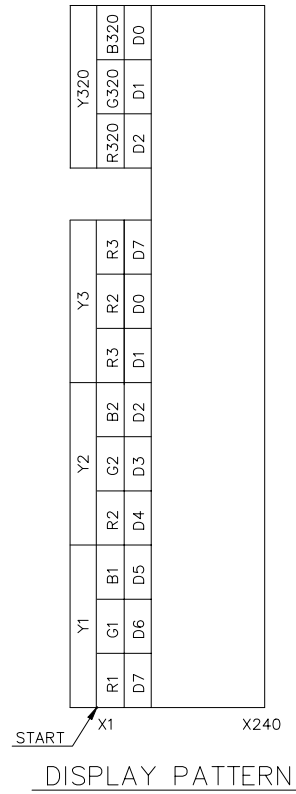
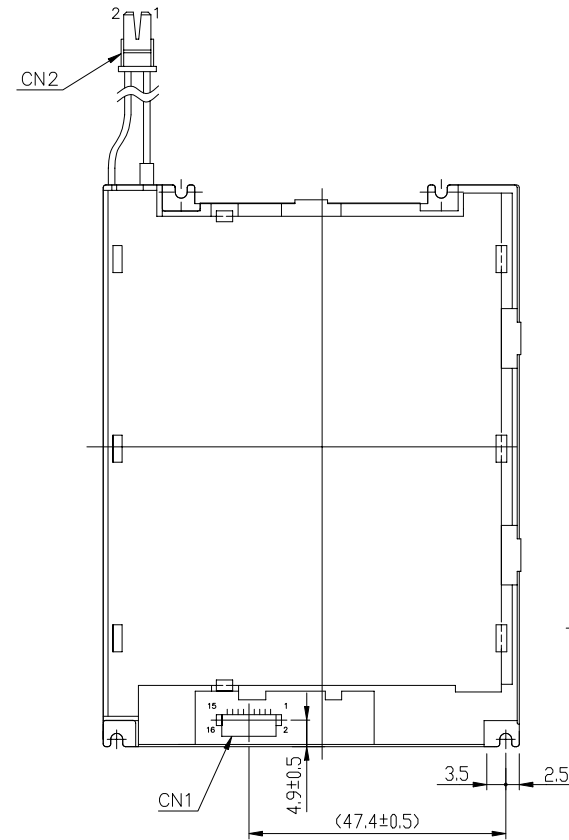
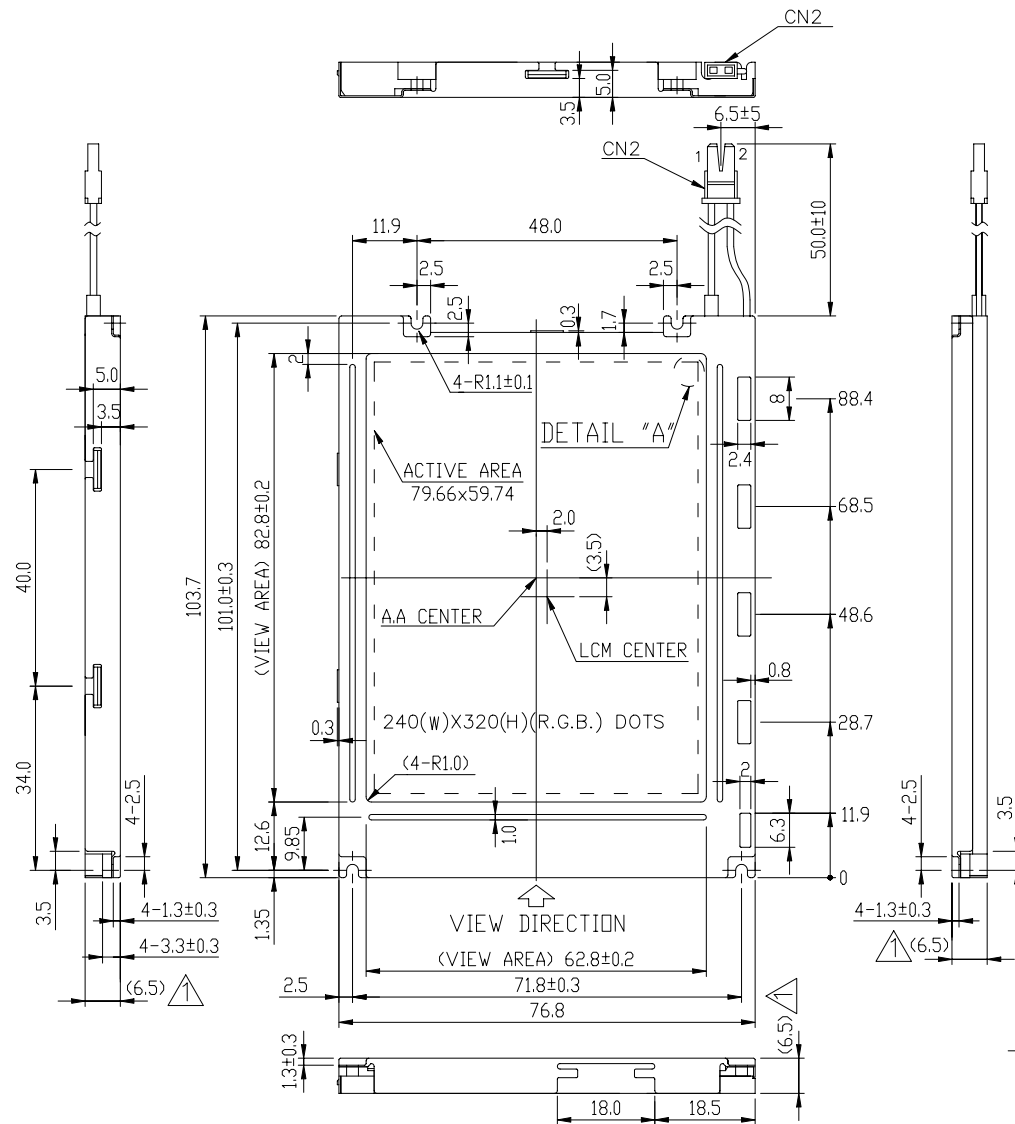

NOTE:  
 1.RESOLUTION: 240 (H) X 320 (V)(R.G.B.) DOTS  
 2.BACKLIGHT: CCFL  
 3.FRAME MATERIAL: SUS304 (0.3mmt)

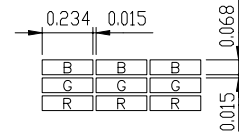

DIMENSION	TOLERANCE
$L \leq 6$	$\pm 0.25$ (mm)
$6 < L \leq 18$	$\pm 0.3$ (mm)
$18 < L \leq 50$	$\pm 0.4$ (mm)
$50 < L \leq 125$	$\pm 0.5$ (mm)
$125 < L$	$\pm 0.6$ (mm)
ANGLE	$\pm 1^\circ$ (DEG)

AZ DISPLAYS, INC.

AGM3224Y

APPROVE	NAME	DATE	THIRD ANGLE P.
APPROVE	TONY CHOU	88.9.13	
CHECK	Louis Lee	88.9.13	
DESIGN	C. J. CHEN	88.9.13	SCALE UNIT
DRAWN	C. J. CHEN	88.9.13	NTS mm

REV. NO.	DESCRIPTION	DATE	DESIGN	CHECK	APPROVE
1	Dimension Modified	88.11.24	M.Y. Lin	Louis Lee	L.C. WU

DWG. NO. M2111-D11A

CN1 : FH12-16S-0.5SV(HRS)/SUITABLE FPC : PITCH 0.5mm WIDTH 8.5mm

PIN NO	SYMBOL	FUNCTION	PIN NO	SYMBOL	FUNCTION
1	D7	DISPLAY DATA	11	DISPOFF	DISPLAY CONTROL L:OFF H:ON
2	D6	DISPLAY DATA	12	CL2	DATA INPUT CLOCK
3	D5	DISPLAY DATA	13	CL1	INPUT DATA LATCH SIGNAL
4	D4	DISPLAY DATA	14	FLM	SCAN START-UP SIGNAL
5	D3	DISPLAY DATA	15	V <sub>SS</sub>	GROUND
6	D2	DISPLAY DATA	16	V <sub>EE</sub>	POWER SUPPLY FOR LCD
7	D1	DISPLAY DATA	SUITABLE CONNECTOR : SM02B-BHSS-1-TB (JST)		
8	D0	DISPLAY DATA	CN2 : BHSR-02VS-1(JST) (PIN1-H.V;PIN2-GND)		
9	V <sub>SS</sub>	GROUND	1	H.V	POWER SUPPLY VOLTAGE FOR CCFL
10	V <sub>DD</sub>	LOGIC SUPPLY VOLTAGE	2	GND	CCFL GND