

Features

- Photo detector and preamplifier in one package
- Enhanced immunity against all kinds of disturbance light
- High performance photo diode and built-in I.C
- High speed response and output
- Low power consumption and easy use

Application

- Light detecting portion of remote control
- TVs, VCRs, Audio equipments, CATV Set Top boxes, Multi-media equipments

Outline Dimensions

unit : mm

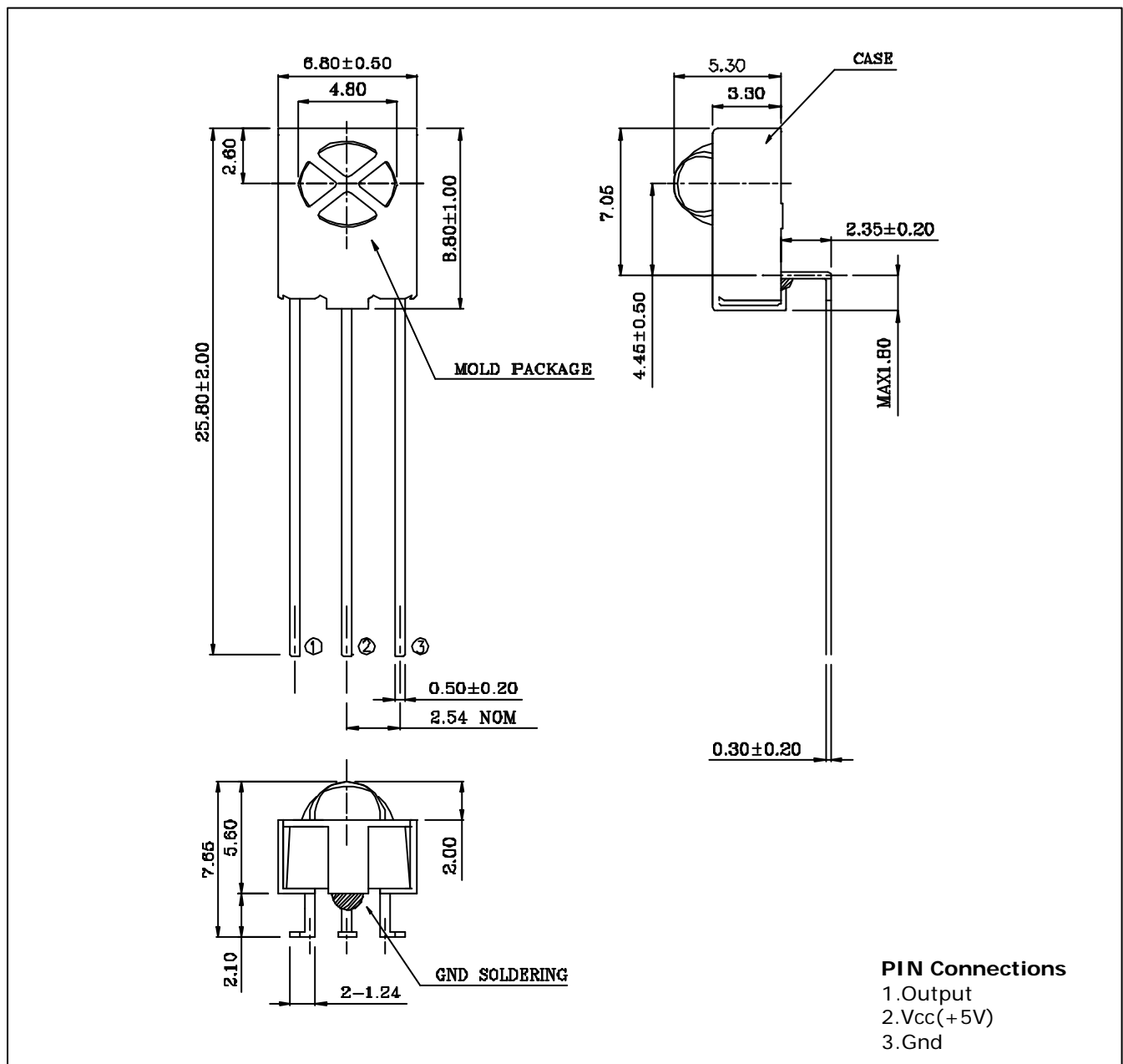

Absolute maximum ratings

Characteristic	Symbol	Ratings	Unit
Supply Voltage	V_{CC}	6.0	V
Power Dissipation	P_D	0.27	W
Operating Temperature	T_{opr}	-10 ~ 60	
Storage Temperature	T_{stg}	-20 ~ 75	
*1Soldering Temperature	T_{sol}	260 within 5 seconds	

*1.Keep the distance more than 2.0mm from PCB to the bottom of package

Electrical Characteristics

($T_a=25^\circ\text{C}$)

Parameter	Symbol	Test Condition	Min.	Typ.	Max.	Unit	
Supply Voltage	V_{CC}	-	4.5	5.0	5.5	V	
Current Consumption	I_{CC}	#1	0.3	-	1.5	mA	
Resonance Frequency	f_C	-	-	38	-	KHz	
Peak sensitivity wavelength	λ_p	-	-	980	-	nm	
H level output voltage	V_{OH}	#2	4.5	5.0	-	V	
L level output voltage	V_{OL}		-	0.2	0.4	V	
H level pules width	T_{wh}		500	-	700	us	
L level pules width	T_{wl}		500	-	700	us	
Arrival distance	L	#2,3,4	$\pm 0^\circ$	-	20	-	m
			$\pm 30^\circ$	-	15	-	
			$\pm 45^\circ$	-	10	-	
Output form	Active low						

Characteristic Diagrams

Fig. 1 Relative Spectral Sensitivity - Wavelength

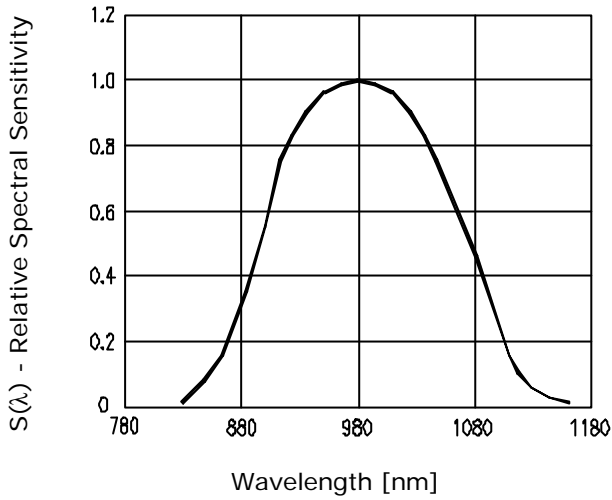
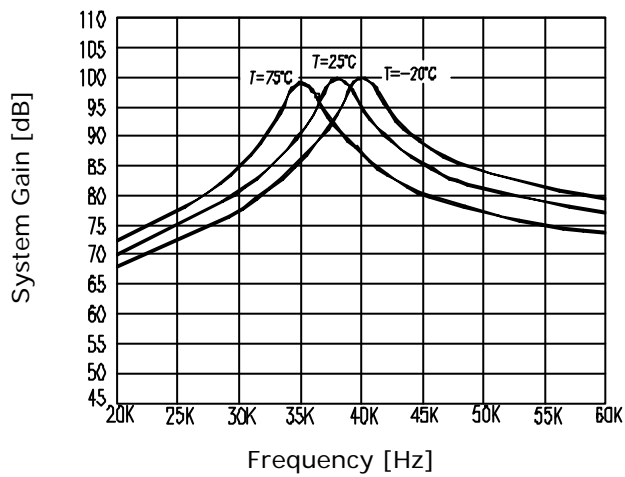
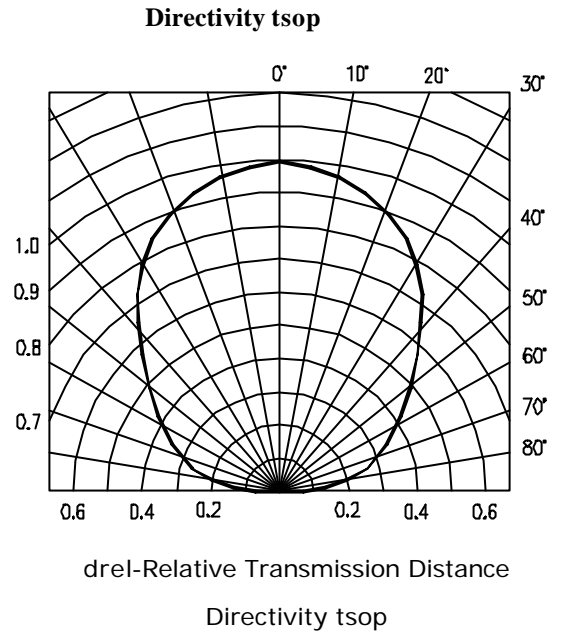

Fig. 2 drel-Relative Transmission Distance



1. No input signal.

2. The burst wave forms shown below in the Fig 1. Shall be transmitted by the standard transmitter.

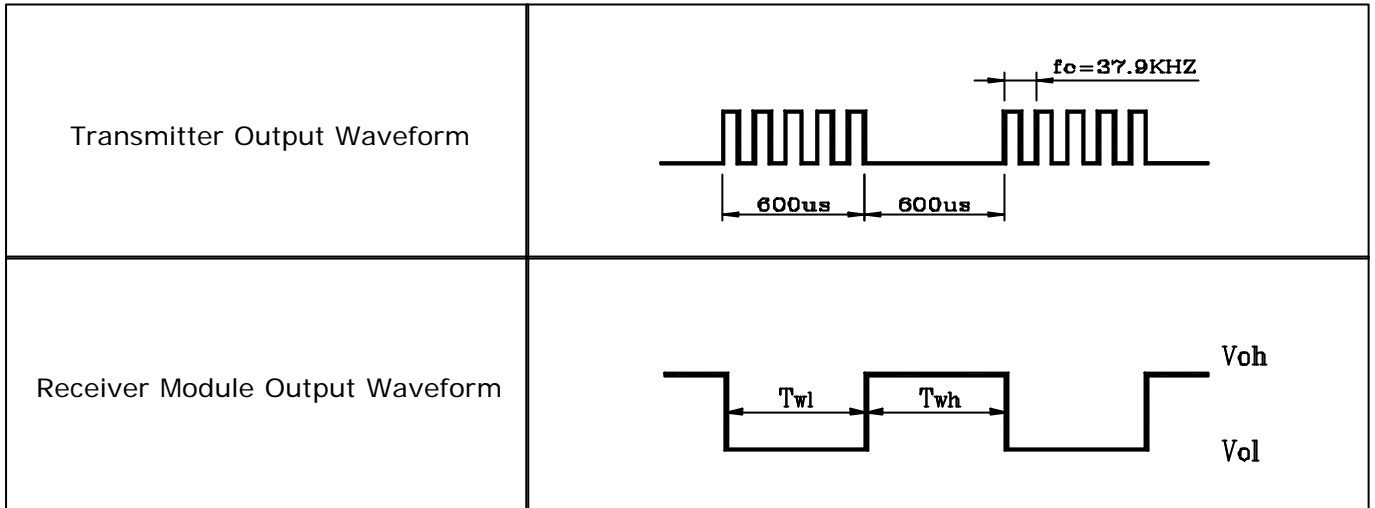
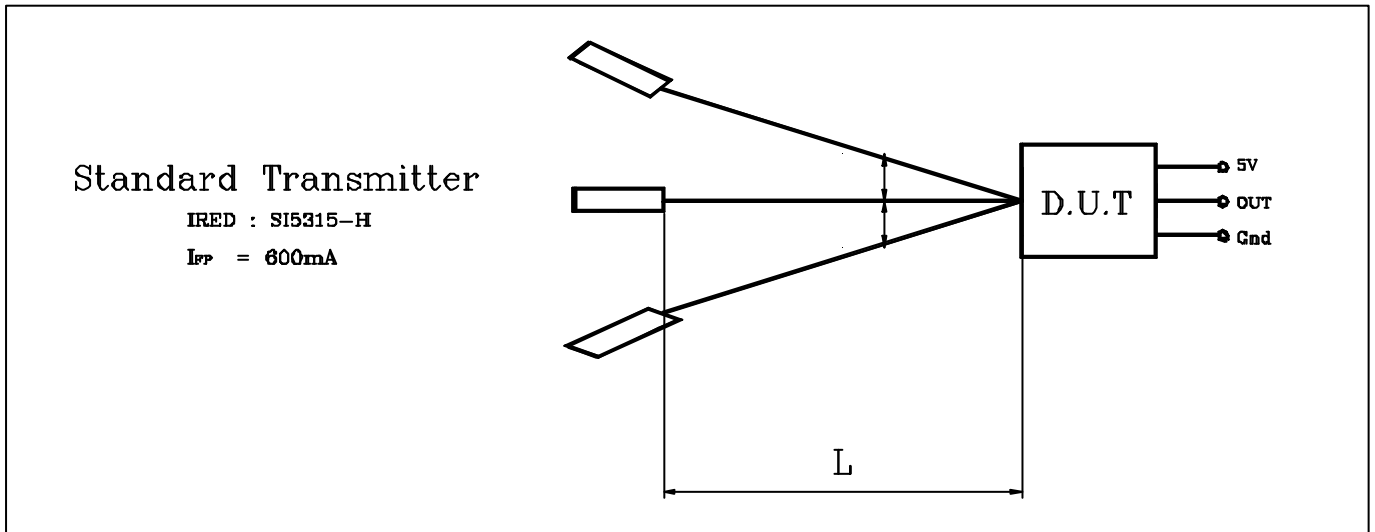

Fig 1. Transmitter & Receiver wave forms

3. The test condition of arrival distance.



#4. The arrival distance is measured in the darkness without disturbing noises.

Reliability Test

Test items	Test condition	Remarks
High temp & High humid	Ta=40 , RH=90%, t=96Hr's	#1, 2
Heat cycle	#2, 3	-
Fall test	#4	-

#1. Supply voltage 5V at the load test.

#2. Electro-optical characteristics shall be satisfied after 2hr's at normal temperature.

#3. Heat cycle test as below Fig2. For 20 cycles under no load.

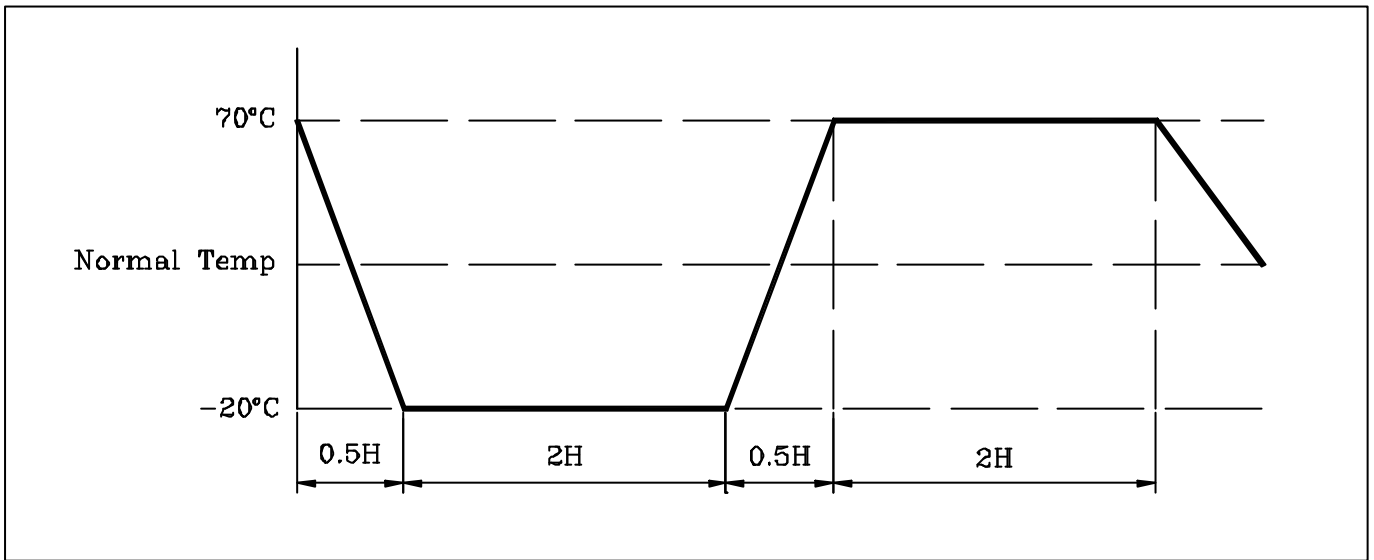

Fig 2. Heat cycle test

#4. Fall test

The test devices to fall three time onto hard wooden board from a level 75 cm

The others

In case of noisy power supply, please serially insert about 47 resistance an about 47 μ F electrolytic capacitance in line as follows.

