

## Features

- Frequency Range 2.4 GHz to 2.5 GHz
- Linear  $P_{out}$  18 dBm Typically
- Gain 20 dB Typically
- $V_{CC}$  from 2.7 V to 3.6 V
- Package: HP-VFQFP-N16 ( $4 \times 4 \text{ mm}^2$ )

## Benefits

- High Efficiency and Biasing Control Extends Battery Life Time
- Reduction of Current Consumption by Power-down Mode
- No External Components for Input Matching
- Space Saving  $4 \times 4 \text{ mm}^2$  Package

Electrostatic sensitive device.  
Observe precautions for handling.



## Description

### Process

The 2.4-GHz power amplifier is designed in Atmel's Silicon-Germanium (SiGe) process and provides excellent noise performance, high gain as well as good power-added efficiency.

### Circuitry

The 802.11b/802.11g PA consists of a two-stage amplifier with a linear output power of 18 dBm. The output stages were realized using an open-collector structure. The IC features  $50\text{-}\Omega$  input matching. Power-up/down and biasing are controlled at the Pin Vcontr. An integrated power detector provides a voltage proportional to the output power.

Figure 1. Block Diagram

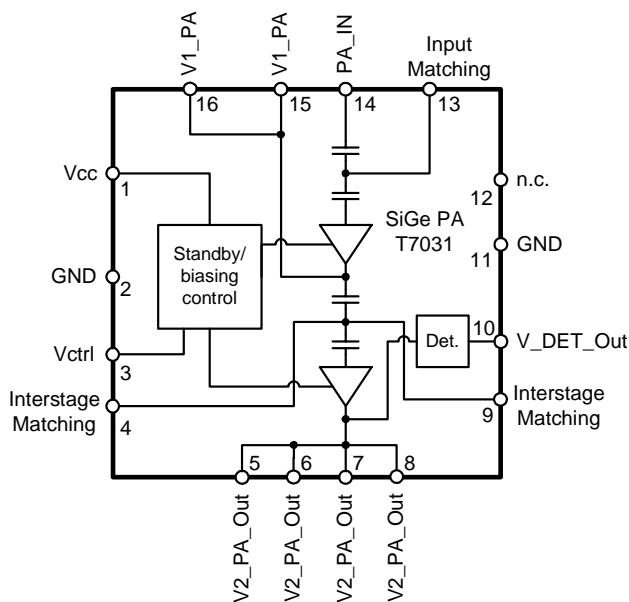

## 2.4-GHz SiGe Power Amplifier for 802.11b and 802.11g WLAN Systems

### T7031

### Preliminary



## Pin Configuration

Figure 2. Pinning HP-VFQFP-N16

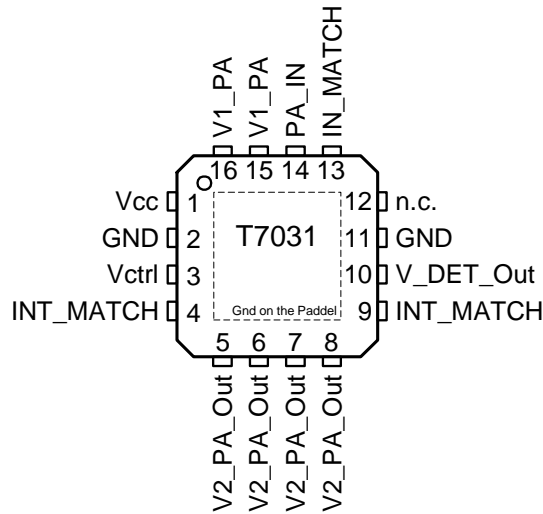

## Pin Description

Pin	Symbol	Function
1	Vcc	Supply voltage
2	GND	Ground
2	Vctrl	Power-up/biasing control voltage
4	INT_MATCH	Interstage matching
5	V2_PA_Out	Power amplifier output and supply voltage for 2nd power amplifier stage
6	V2_PA_Out	Power amplifier output and supply voltage for 2nd power amplifier stage
7	V2_PA_Out	Power amplifier output and supply voltage for 2nd power amplifier stage
8	V2_PA_Out	Power amplifier output and supply voltage for 2nd power amplifier stage
9	INT_MATCH	Interstage matching
10	V_DET_Out	Power detector output
11	GND	Ground
12	n.c.	Not connected
13	IN_MATCH	Input matching
14	PA_IN	Power amplifier input
15	V1_PA	Supply voltage for 1 <sup>st</sup> power amplifier stage
16	V1_PA	Supply voltage for 1 <sup>st</sup> power amplifier stage
Slug	–	Ground

## Absolute Maximum Ratings

Parameters	Symbol	Value	Unit
Supply voltage	$V_{CC}$	6	V
Supply current	$I_{CC}$	200	mA
Junction temperature	$T_j$	150	°C
Storage temperature	$T_{Stg}$	-40 to +125	°C
Input RF power	$P_{in}$	12	dBm
Control voltage power up/down and biasing	$V_{contr}$	0 to 3	V

## Thermal Resistance

Parameters	Symbol	Value	Unit
Junction ambient	$R_{thJA}$	35	K/W

## Operating Range

Parameters	Symbol	Value	Unit
Supply voltage range	$V_{CC}$	2.7 to 3.6	V
Ambient temperature range	$T_{amb}$	-30 to +80	°C

## Electrical Characteristics

No.	Parameters	Test Conditions	Pin	Symbol	Min.	Typ.	Max.	Unit	Type*
	Supply voltage			$V_{CC}$	2.7	3.3	3.6	V	
	Frequency Range			f	2400		2500	MHz	
	P1dB output Power			P1dB		23		dBm	
	Saturated output power	For reference		$P_{sat}$		24		dBm	
	Linear power gain			GI		20		dB	
	Current Consumption	$P_{out} = 18$ dBm		$I_{CC}$		90		mA	
		Power-down mode		$I_{pd}$			15	µA	
	Power added efficiency	$P_{out} = 18$ dBm		PAE		20		%	
	Adjacent channel power rejection	$P_{out} = 18$ dBm <sup>(2)</sup> First side lobe Second side lobe		ACPR1		-33		dBc	
				ACPR2		-55		dBc	
	2nd harmonic	P1dB		2f <sub>out</sub>		-30		dBc	
	Input 50 Ω VSWR			VSWR <sub>in</sub>			2:1		
	Output 50 Ω VSWR	With external matching		VSWR <sub>out</sub>			2:1		
	Reverse isolation	On and off mode		ISO <sub>r</sub>		35		dB	

\*) Type means: A = 100% tested, B = 100% correlation tested, C = Characterized on samples, D = Design parameter

- Notes: 1. The current of the PA can be controlled by the Pin V<sub>contr</sub>. For lower output level demand, the current can be reduced.  
2. With IEEE 802.11b conform modulation.

## Electrical Characteristics (Continued)

No.	Parameters	Test Conditions	Pin	Symbol	Min.	Typ.	Max.	Unit	Type*
	Control voltage range	PA operating mode (Biasing) <sup>(1)</sup>		Vcontr	1		2	V	
		Power down		Vcontr			0.2	V	
<b>Power Detector</b>									
	Maximum power			PDETmax		22		dBm	
	Minimum power			PDETmin		2		dBm	
	Settling time			tset		0.5		μs	
	Maximum voltage			VDETmax		2		V	

\*) Type means: A = 100% tested, B = 100% correlation tested, C = Characterized on samples, D = Design parameter

- Notes: 1. The current of the PA can be controlled by the Pin Vcontr. For lower output level demand, the current can be reduced.  
2. With IEEE 802.11b conform modulation.

**Figure 3.** Application Circuit

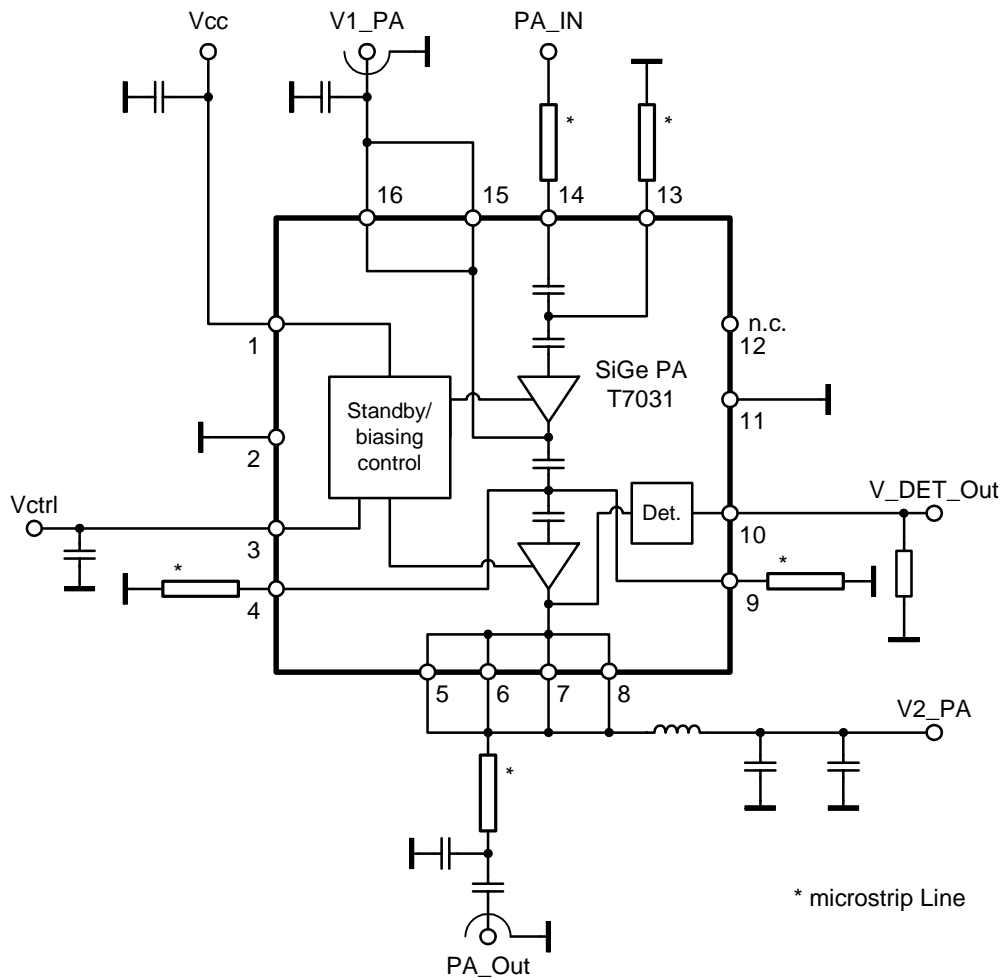

### Ordering Information

Extended Type Number	Package	Remarks	MOQ
T7031M-PEP	HP-VFQFP-N16	Taped and reeled	1500
T7031M-PEQ	HP-VFQFP-N16	Taped and reeled	6000

### Package Information

Package: HP-VFQFP-N16  
 (acc. JEDEC OUTLINE No. MO-220)

Dimensions in mm

Not indicated tolerances  $\pm 0.05$

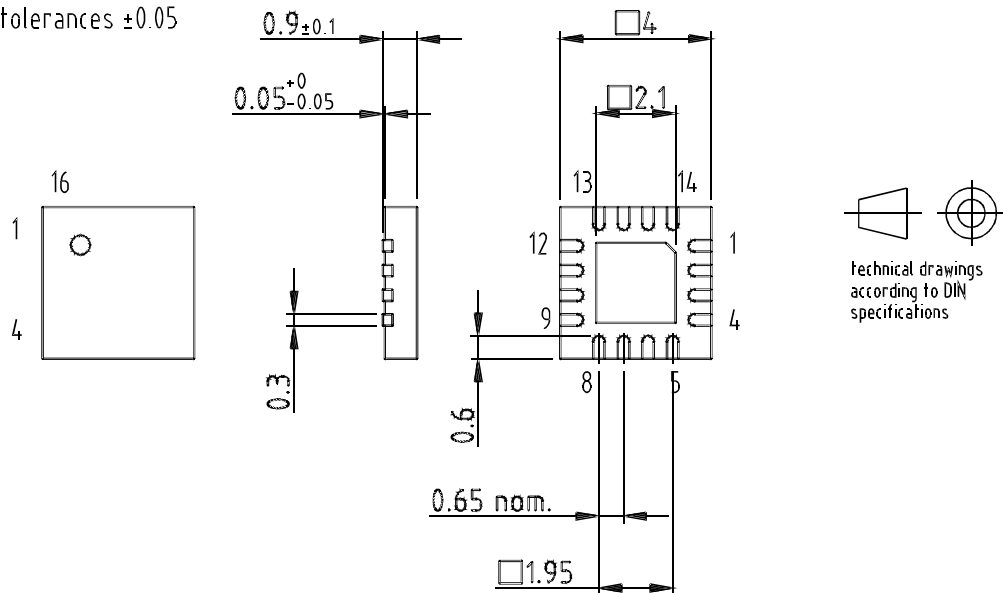

Drawing-No.: 6.543-5090.01-4

Issue: 1; 05.09.02



## Atmel Headquarters

### *Corporate Headquarters*

2325 Orchard Parkway  
San Jose, CA 95131  
TEL 1(408) 441-0311  
FAX 1(408) 487-2600

### *Europe*

Atmel Sarl  
Route des Arsenaux 41  
Case Postale 80  
CH-1705 Fribourg  
Switzerland  
TEL (41) 26-426-5555  
FAX (41) 26-426-5500

### *Asia*

Room 1219  
Chinachem Golden Plaza  
77 Mody Road Tsimhatsui  
East Kowloon  
Hong Kong  
TEL (852) 2721-9778  
FAX (852) 2722-1369

### *Japan*

9F, Tonetsu Shinkawa Bldg.  
1-24-8 Shinkawa  
Chuo-ku, Tokyo 104-0033  
Japan  
TEL (81) 3-3523-3551  
FAX (81) 3-3523-7581

## Atmel Operations

### *Memory*

2325 Orchard Parkway  
San Jose, CA 95131  
TEL 1(408) 441-0311  
FAX 1(408) 436-4314

### *Microcontrollers*

2325 Orchard Parkway  
San Jose, CA 95131  
TEL 1(408) 441-0311  
FAX 1(408) 436-4314

La Chantrerie  
BP 70602  
44306 Nantes Cedex 3, France  
TEL (33) 2-40-18-18-18  
FAX (33) 2-40-18-19-60

### *ASIC/ASSP/Smart Cards*

Zone Industrielle  
13106 Rousset Cedex, France  
TEL (33) 4-42-53-60-00  
FAX (33) 4-42-53-60-01

1150 East Cheyenne Mtn. Blvd.  
Colorado Springs, CO 80906  
TEL 1(719) 576-3300  
FAX 1(719) 540-1759

Scottish Enterprise Technology Park  
Maxwell Building  
East Kilbride G75 0QR, Scotland  
TEL (44) 1355-803-000  
FAX (44) 1355-242-743

### *RF/Automotive*

Theresienstrasse 2  
Postfach 3535  
74025 Heilbronn, Germany  
TEL (49) 71-31-67-0  
FAX (49) 71-31-67-2340

1150 East Cheyenne Mtn. Blvd.  
Colorado Springs, CO 80906  
TEL 1(719) 576-3300  
FAX 1(719) 540-1759

### *Biometrics/Imaging/Hi-Rel MPU/ High Speed Converters/RF Datacom*

Avenue de Rochepleine  
BP 123  
38521 Saint-Egreve Cedex, France  
TEL (33) 4-76-58-30-00  
FAX (33) 4-76-58-34-80

---

### *e-mail*

literature@atmel.com

### *Web Site*

<http://www.atmel.com>

### © Atmel Corporation 2002.

Atmel Corporation makes no warranty for the use of its products, other than those expressly contained in the Company's standard warranty which is detailed in Atmel's Terms and Conditions located on the Company's web site. The Company assumes no responsibility for any errors which may appear in this document, reserves the right to change devices or specifications detailed herein at any time without notice, and does not make any commitment to update the information contained herein. No licenses to patents or other intellectual property of Atmel are granted by the Company in connection with the sale of Atmel products, expressly or by implication. Atmel's products are not authorized for use as critical components in life support devices or systems.

Atmel® is the registered trademark of Atmel.

Other terms and product names may be the trademarks of others.



Printed on recycled paper.