Features

- First-in First-out Dual Port Memory
- 4096-bit x 9 Organization
- Fast Flag and Access Times: 15, 30 ns
- Wide Temperature Range: -55°C to +125°C
- Fully Expandable by Word Width or Depth
- Asynchronous Read/Write Operations
- Empty, Full and Half Flags in Single Device Mode
- Retransmit Capability
- Bi-directional Applications
- Battery Backup Operation: 2V Data Retention
- TTL Compatible
- Single 5V \pm 10% Power Supply
- No Single Event Latch-up below a LET Threshold of 80 MeV/mg/cm²
- Tested up to a Total Dose of 30 krad (Si) according to MIL STD 883 Method 1019
- QML Q and V with SMD 5962-89568
- ESCC B with specification 9301/049

Description

The M67204H implements a first-in first-out algorithm, featuring asynchronous read/write operations. The FULL and EMPTY flags prevent data overflow and underflow. The expansion logic allows unlimited expansion in word size and depth with no timing penalties. Twin address pointers automatically generate internal read and write addresses, and no external address information is required for the Atmel FIFOs. address pointers are automatically incremented with the write pin and read pin. The 9 bits wide data are used in data communications applications where a parity bit for error checking is necessary. The retransmit pin reset the read pointer to zero without affecting the write pointer. This is very useful for retransmitting data when an error is detected in the system.

Using an array of eight transistors (8T) memory cell, the M67204H combines an extremely low standby supply current (typ = 0.1 μ A) with a fast access time at 15 ns over the full temperature range. All versions offer battery backup data retention capability with a typical power consumption at less than 2 μ W.

The M67204H is processed according to the methods of the latest revision of the MIL PRF 38535 (Q and V) or ESA SCC 9000.

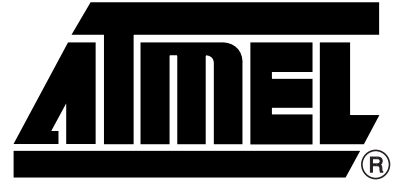

**Rad. Tolerant
High Speed
4 Kb x 9
Parallel FIFO**

M67204H



Block Diagram

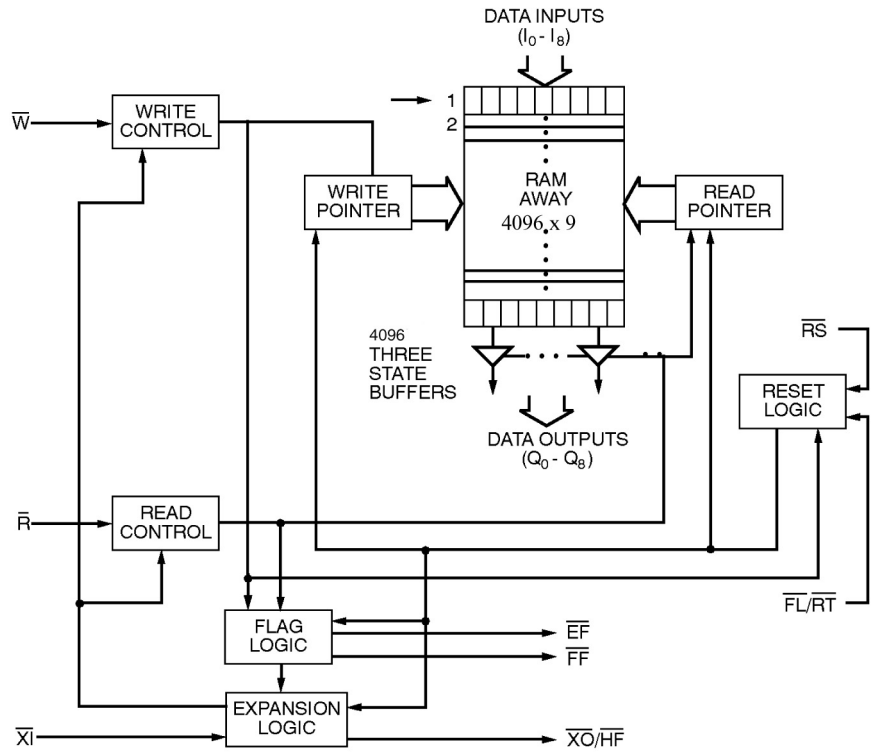

Pin Configuration

DIL ceramic 28-pin 300 mils
 FP 28-pin 400 mils

(top view)

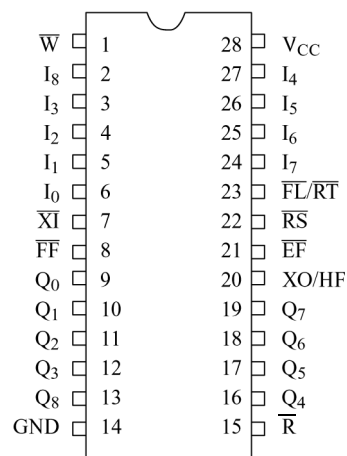

Pin Description

Names	Description
$\overline{\text{FF}}$	Full Flag
$\overline{\text{XO/HF}}$	Expansion Out/Half-Full Flag
$\overline{\text{XI}}$	Expansion IN
$\overline{\text{FL/RT}}$	First Load/Retransmit
VCC	Power Supply
GND	Ground
I0-8	Inputs
Q0-8	Outputs
$\overline{\text{W}}$	Write Enable
$\overline{\text{R}}$	Read Enable
$\overline{\text{RS}}$	Reset
$\overline{\text{EF}}$	Empty Flag

Data In ($I_0 - I_8$)

Data inputs for 9-bit data

Reset ($\overline{\text{RS}}$)

Reset occurs whenever the Reset ($\overline{\text{RS}}$) input is taken to a low state. Reset returns both internal read and write pointers to the first location. A reset is required after power-up before a write operation can be enabled. Both the Read Enable ($\overline{\text{R}}$) and Write Enable ($\overline{\text{W}}$) inputs must be in the high state during the period shown in Figure 1 (i.e. t_{RSS} before the rising edge of $\overline{\text{RS}}$) and should not change until t_{RSR} after the rising edge of $\overline{\text{RS}}$. The Half-Full Flag ($\overline{\text{HF}}$) will be reset to high After Reset (RS).

Figure 1. Reset

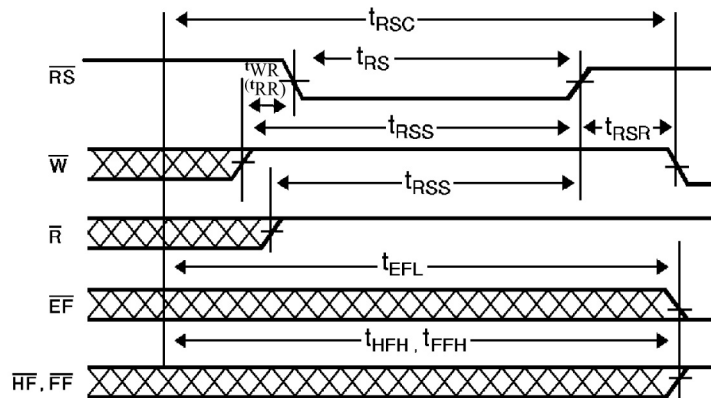

- Notes:
- $\overline{\text{EF}}$, $\overline{\text{FF}}$ and $\overline{\text{HF}}$ may change status during reset, but flags will be valid at t_{RSC} .
 - $\overline{\text{W}}$ and $\overline{\text{R}}$ = VIH around the rising edge of RS.

Write Enable (\overline{W})

A write cycle is initiated on the falling edge of this input if the Full Flag (\overline{FF}) is not set. Data set-up and hold times must be maintained in the rise time of the leading edge of the Write Enable (\overline{W}). Data is stored sequentially in the Ram array, regardless of any current read operation.

Once half the memory is filled, and during the falling edge of the next write operation, the Half-Full Flag (\overline{HF}) will be set to low and remain in this state until the difference between the write and read pointers is less than or equal to half of the total available memory in the device. The Half-Full Flag (\overline{HF}) is then reset by the rising edge of the read operation.

To prevent data overflow, the Full Flag (\overline{FF}) will go low, inhibiting further write operations. On completion of a valid read operation, the Full Flag (\overline{FF}) will go high after TRFF, allowing a valid write to begin. When the FIFO stack is full, the internal write pointer is blocked from \overline{W} , so that external changes to \overline{W} will have no effect on the full FIFO stack.

Read Enable (\overline{R})

A read cycle is initiated on the falling edge of the Read Enable (\overline{R}) provided that the Empty Flag (\overline{EF}) is not set. The data is accessed on a first in/first out basis, not with standing any current write operations. After Read Enable (\overline{R}) goes high, the Data Outputs (Q0 - Q8) will return to a high impedance state until the next Read operation. When all the data in the FIFO stack has been read, the Empty Flag (\overline{EF}) will go low, allowing the "final" read cycle, but inhibiting further read operations whilst the data outputs remain in a high impedance state. Once a valid write operation has been completed, the Empty Flag (\overline{EF}) will go high after tWEF and a valid read may then be initiated. When the FIFO stack is empty, the internal read pointer is blocked from \overline{R} , so that external changes to \overline{R} will have no effect on the empty FIFO stack.

First Load/Retransmit (FL/RT)

This is a dual-purpose input. In the Depth Expansion Mode, this pin is connected to ground to indicate that it is the first loaded (see Operating Modes). In the Single Device Mode, this pin acts as the retransmit input. The Single Device Mode is initiated by connecting the Expansion In (\overline{XI}) to ground.

The M67204H can be made to retransmit data when the Retransmit Enable Control (\overline{RT}) input is pulsed low. A retransmit operation will set the internal read point to the first location and will not affect the write pointer. Read Enable (\overline{R}) and Write Enable (\overline{W}) must be in the high state during retransmit. The retransmit feature is intended for use when a number of writes equals to or less than the depth of the FIFO has occurred since the last RS cycle. The retransmit feature is not compatible with the Depth Expansion Mode and will affect the Half-Full Flag (\overline{HF}), in accordance with the relative locations of the read and write pointers.

Expansion In (\overline{XI})

This input is a dual-purpose pin. Expansion In (\overline{XI}) is connected to GND to indicate an operation in the single device mode. Expansion In (\overline{XI}) is connected to Expansion Out (\overline{XO}) of the previous device in the Depth Expansion or Daisy Chain modes.

Full Flag (\overline{FF})

The Full Flag (\overline{FF}) will go low, inhibiting further write operations when the write pointer is one location less than the read pointer, indicating that the device is full. If the read pointer is not moved after Reset (\overline{RS}), the Full Flag (\overline{FF}) will go low after 4096 writes.

Empty Flag (\overline{EF})

The Empty Flag (\overline{EF}) will go low, inhibiting further read operations when the read pointer is equal to the write pointer, indicating that the device is empty.

Expansion Out/Half-full Flag (XO/HF)

This is a dual-purpose output. In the single device mode, when Expansion In (\overline{XI}) is connected to ground, this output acts as an indication of a half-full memory.

After half the memory is filled and on the falling edge of the next write operation, the Half-Full Flag (\overline{HF}) will be set to low and will remain set until the difference between the write and read pointers is less than or equal to half of the total memory of the device. The Half-Full Flag (\overline{HF}) is then reset by the rising edge of the read operation.

In the Depth Expansion Mode, Expansion In (\overline{XI}) is connected to Expansion Out (\overline{XO}) of the previous device. This output acts as a signal to the next device in the Daisy Chain by providing a pulse to the next device when the previous device reaches the last memory location.

Data Output ($Q_0 - Q_8$)

DATA output for 9-bit wide data. This data is in a high impedance condition whenever Read (\overline{R}) is in a high state.

Functional Description

Single Device Mode

A single M67204H may be used when the application requirements are for 4096 words or less. The M67204H is in a Single Device Configuration when the Expansion In (\overline{XI}) control input is grounded (see Figure 2). In this mode the Half-Full Flag (\overline{HF}), which is an active low output, is shared with Expansion Out (XO).

Figure 2. Block Diagram of Single 4096 bits x 9

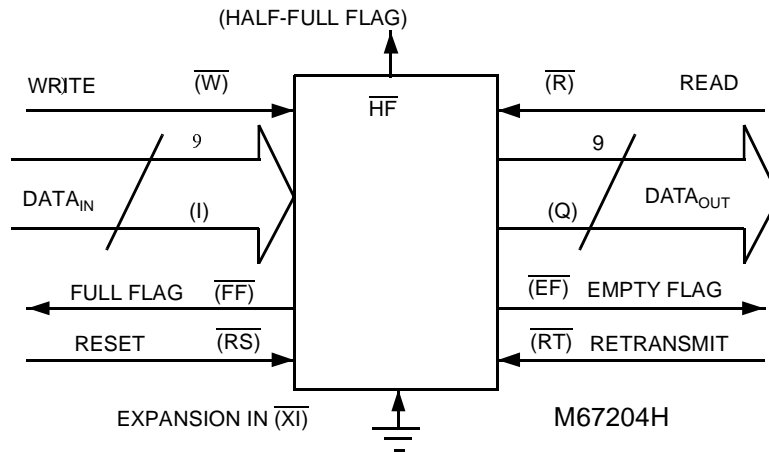

Width Expansion Mode

Word width may be increased simply by connecting the corresponding input control signals of multiple devices. Status flags (\overline{EF} , \overline{FF} and \overline{HF}) can be detected from any device. Figure 3 demonstrates an 18-bit word width by using two M67204H. Any word width can be attained by adding additional M67204H.

Figure 3. Block Diagram of 4096 bits x 18 FIFO Memory Used in Width Expansion Mode

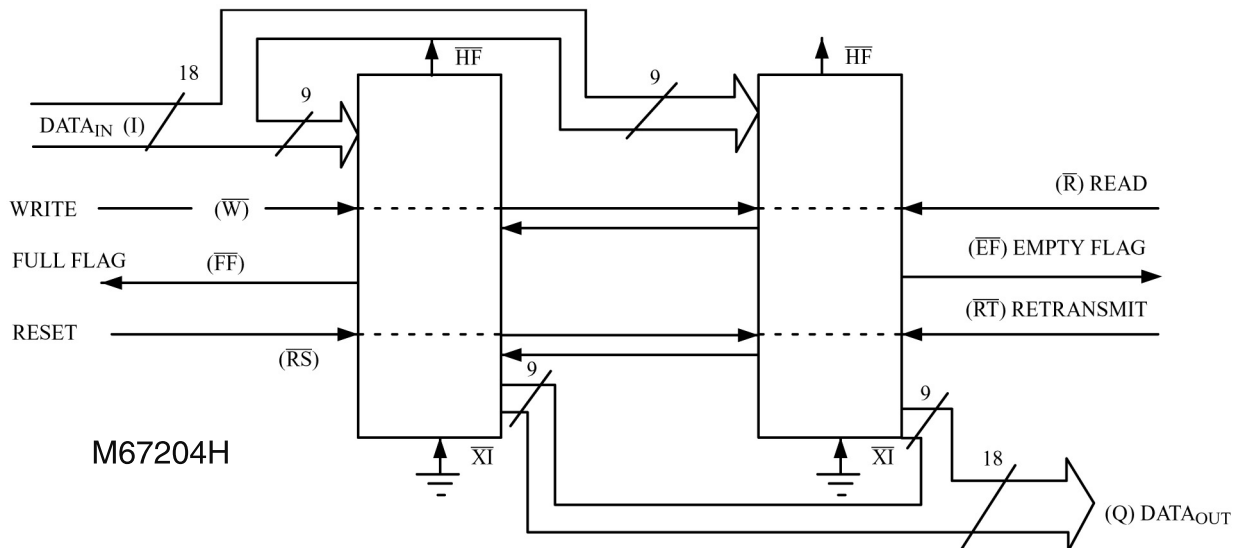

Note: Flag detection is accomplished by monitoring the \overline{FF} , \overline{EF} and the \overline{HF} signals on either (any) device used in the width expansion configuration. Do not connect any output control signals together.

Table 1. Reset and Retransmit
Single Device Configuration/Width Expansion Mode

Mode	Inputs			Internal Status		Outputs		
	RS	RT	XI	Read Pointer	Write Pointer	EF	FF	HF
Reset	0	X	0	Location Zero	Location Zero	0	1	1
Retransmit	1	0	0	Location Zero	Unchanged	X	X	X
Read/Write	1	1	0	Increment	Increment ⁽¹⁾	X	X	X

Note: 1. Pointer will increment if flag is high.

Table 2. Reset and First Load Truth Table
Depth Expansion/Compound Expansion Mode

Mode	Inputs			Internal Status		Outputs	
	RS	RT	XI	Read Pointer	Write Pointer	EF	FF
Reset First Device	0	0	(1)	Location Zero	Location Zero	0	1
Reset All Other Devices	0	1	(1)	Location Zero	Location Zero	0	1
Read/Write	1	X	(1)	X	X	X	X

Note: 1. \overline{XI} is connected to \overline{XO} of previous device.
See Figure 4.

Depth Expansion (Daisy Chain) Mode

The M67204H can be easily adapted for applications which require more than 4096 words. Figure 4 demonstrates Depth Expansion using three M67204H. Any depth can be achieved by adding additional M67204H.

The M67204H operates in the Depth Expansion configuration if the following conditions are met:

1. The first device must be designated by connecting the First Load (\overline{FL}) control input to ground.
2. All other devices must have \overline{FL} in the high state.
3. The Expansion Out (\overline{XO}) pin of each device must be connected to the Expansion In (\overline{XI}) pin of the next device. See Figure 4.
4. External logic is needed to generate a composite Full Flag (\overline{FF}) and Empty Flag (\overline{EF}). This requires that all \overline{EF} 's and all \overline{FF} 's be ORed (i.e. all must be set to generate the correct composite \overline{FF} or \overline{EF}). See Figure 4.
5. The Retransmit (\overline{RT}) function and Half-Full Flag (\overline{HF}) are not available in the Depth Expansion Mode.

Compound Expansion Module

It is quite simple to apply the two expansion techniques described above together to create large FIFO arrays (see Figure 5).

Bidirectional Mode

Applications which require data buffering between two systems (each system being capable of Read and Write operations) can be created by coupling M67204H as shown in Figure 6. Care must be taken to ensure that the appropriate flag is monitored by each system (i.e. \overline{FF} is monitored on the device on which \overline{W} is in use; \overline{EF} is monitored on the device on which \overline{R} is in use). Both Depth Expansion and Width Expansion may be used in this mode.

Data Flow – Through Modes

Two types of flow-through modes are permitted: a read flow-through and a write flow-through mode. In the read flow-through mode (Figure 17) the FIFO stack allows a single word to be read after one word has been written to an empty FIFO stack. The data is enabled on the bus at $(t_{WEF} + t_A)$ ns after the leading edge of \overline{W} which is known as the first write edge and remains on the bus until the \overline{R} line is raised from low to high, after which the bus will go into a three-state mode after t_{RHZ} ns. The \overline{EF} line will show a pulse indicating temporary reset and then will be set. In the interval in which \overline{R} is low, more words may be written to the FIFO stack (the subsequent writes after the first write edge will reset the Empty Flag); however, the same word (written on the first write edge) presented to the output bus as the read pointer will not be incremented if \overline{R} is low. On toggling \overline{R} , the remaining words written to the FIFO will appear on the output bus in accordance with the read cycle timings.

In the write flow-through mode (Figure 18), the FIFO stack allows a single word of data to be written immediately after a single word of data has been read from a full FIFO stack. The \overline{R} line causes the \overline{FF} to be reset, but the \overline{W} line, being low, causes it to be set again in anticipation of a new data word. The new word is loaded into the FIFO stack on the leading edge of \overline{W} . The \overline{W} line must be toggled when \overline{FF} is not set in order to write new data into the FIFO stack and to increment the write pointer.

Figure 4. Block Diagram of 12288 bits \times 9 FIFO Memory (Depth Expansion)

Figure 5. Compound FIFO Expansion

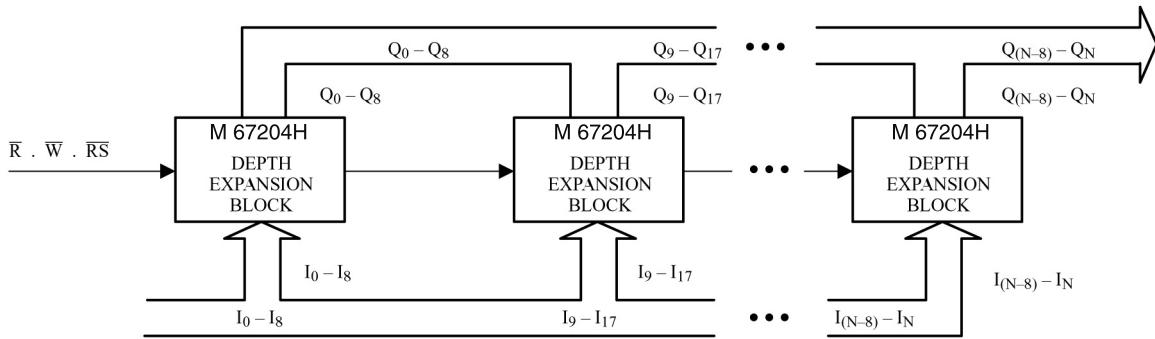

- Notes: 1. For depth expansion block see section on Depth Expansion and Figure 4.
 2. For Flag detection see section on Width Expansion and Figure 3.

Figure 6. Bidirectional FIFO Mode

Electrical Characteristics

Absolute Maximum Ratings

Supply Voltage (VCC - GND):..... - 0.5V to 7.0V
Input or Output Voltage Applied:..(GND - 0.3V) to (Vcc + 0.3V)
Storage Temperature: - 65 °C to + 150 °C

*NOTICE: Stresses beyond those listed under "Absolute Maximum Ratings" may cause permanent damage to the device. This is a stress rating only and functional operation of the device at these or any other conditions beyond those indicated in the operational sections of this specification is not implied. Exposure to absolute maximum rating conditions for extended periods may affect device reliability.

DC Parameters

Table 3. DC Test Conditions

TA = - 55°C to + 125°C; Vss = 0V; Vcc = 4.5V to 5.5V

Parameter	Description	M M67204H-30	M M67204H-15	Unit	Value
I _{CCOP} ⁽¹⁾	Operating supply current	110	120	mA	Max
I _{CCSB} ⁽²⁾	Standby supply current	5	5	mA	Max
I _{CCPD} ⁽³⁾	Power down current	400	400	µA	Max
ILI ⁽⁴⁾	Input leakage current	± 1		µA	Max
ILO ⁽⁵⁾	Output leakage current	± 1		µA	Max
VIL ⁽⁶⁾	Input low voltage	0.8		V	Max
VIH ⁽⁶⁾	Input high voltage	2.2		V	Min
VOL ⁽⁷⁾	Output low voltage	0.4		V	Max
VOH ⁽⁷⁾	Output high voltage	2.4		V	Min
C IN ⁽⁸⁾	Input capacitance	8		pF	Max
C OUT ⁽⁸⁾	Output capacitance	8		pF	Max

1. I_{cc} measurements are made with outputs open.
2. $\bar{R} = \bar{W} = \bar{RS} = \bar{FL/RT} = \bar{VIH}$.
3. All input = V_{cc}.
4. $0.4 \leq V_{in} \leq V_{cc}$.
5. $\bar{R} = \bar{VIH}$, $0.4 \leq \bar{VOUT} \leq \bar{VCC}$.
6. VIH max = V_{cc} + 0.3V. VIL min = -0.3V or -1V pulse width 50 ns. For XI input, VIH= 2.8V
7. V_{cc} min, IOL = 8 mA, IOH = -2 mA.
8. Guaranteed but not tested.

AC Parameters

AC Test Conditions

Input pulse levels: Gnd to 3.0V
 Input rise/Fall times: 5 ns
 Input timing reference levels: 1.5V
 Output reference levels: 1.5V
 Output load: See Figure 7

Figure 7. Output Load

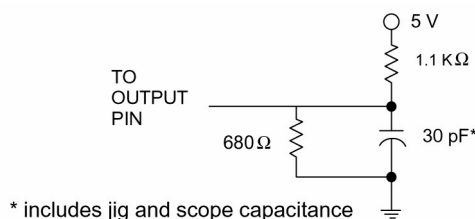

Table 4. AC Test Conditions

Symbol ⁽¹⁾	Symbol ⁽²⁾	Parameter ^{(3) (4)}	M67204H- 15		M67204H- 30		Unit
			Min.	Max.	Min.	Max.	
Read Cycle							
TRLRL	tRC	Read cycle time	25	-	40	-	ns
TRLQV	tA	Access time		15		30	ns
TRHRL	tRR	Read recovery time	10	-	10	-	ns
TRLRH	tRPW	Read pulse width ⁽⁵⁾	15	-	30	-	ns
TRLQX	tRLZ	Read low to data low Z ⁽⁶⁾	0	-	5	-	ns
TWHQX	tWLZ	Write high to data low Z ^{(6) (7)}	3	-	5	-	ns
TRHQX	tDV	Data valid from read high	5	-	5	-	ns
TRHQZ	tRHZ	Read high to data high Z ⁽⁶⁾	-	15	-	20	ns
Write Cycle							
TWLWL	tWC	Write cycle time	25	-	40	-	ns
TWLWH	tWPW	Write pulse width ⁽⁵⁾	15	-	30	-	ns
TWHWL	tWR	Write recovery time	10	-	10	-	ns
TDVWH	tDS	Data set-up time	9	-	18	-	ns
TWHDX	tDH	Data hold time	0	-	0	-	ns
Reset Cycle							
TRSLWL	tRSC	Reset cycle time	25	-	40	-	ns
TRSLRSH	tRS	Reset pulse width ⁽⁵⁾	15	-	30	-	ns
TWHRSH	tRSS	Reset set-up time	20	-	30	-	ns

Table 4. AC Test Conditions (Continued)

Symbol ⁽¹⁾	Symbol ⁽²⁾	Parameter ^{(3) (4)}	M67204H- 15		M67204H- 30		Unit
			Min.	Max.	Min.	Max.	
TRSHWL	tRSR	Reset recovery time	10	–	10	–	ns
Retransmit Cycle							
TRTLWL	tRTC	Retransmit cycle time	25	–	40	–	ns
TRTLRTH	tRT	Retransmit pulse width ⁽⁵⁾	15	–	30	–	ns
TWHRTH	tRTS	Retransmit set-up time ⁽⁶⁾	15	–	30	–	ns
TRTHWL	tRTR	Retransmit recovery time	10	–	10	–	ns
Flags							
TRSLEFL	tEFL	Reset to EF low	–	25	–	30	ns
TRSLFFH	tHFH, tFFH	Reset to HF/FF high	–	25	–	30	ns
TRLEFL	tREF	Read low to EF low	–	25	–	30	ns
TRHFFH	tRFF	Read high to FF high	–	25	–	30	ns
TEFHRH	tRPE	Read width after EF high	15	–	30	–	ns
TWHEFH	tWEF	Write high to EF high	–	15	–	30	ns
TWLFFL	tWFF	Write low to FF low	–	20	–	30	ns
TWLHFL	tWHF	Write low to HF low	–	30	–	30	ns
TRHFFH	tRHF	Read high to HF high	–	30	–	30	ns
TFHWH	tWPF	Write width after FF high	15	–	30	–	ns
Expansion							
TWLXOL	tXOL	Read/Write to XO low	–	15	–	30	ns
TWHXOH	tXOH	Read/Write to XO high	–	15	–	30	ns
TXILXIH	tXI	XI pulse width	15	–	30	–	ns
TXIHXIL	tXIR	XI recovery time	10	–	10	–	ns
TXILRL	tXIS	XI set-up time	10	–	10	–	ns

1. STD symbol.
2. ALT symbol.
3. Timings referenced as in ac test conditions.
4. All parameters tested only.
5. Pulse widths less than minimum value are not allowed.
6. Values guaranteed by design, not currently tested.
7. Only applies to read data flow-through mode.

Figure 8. Asynchronous Write and Read Operation

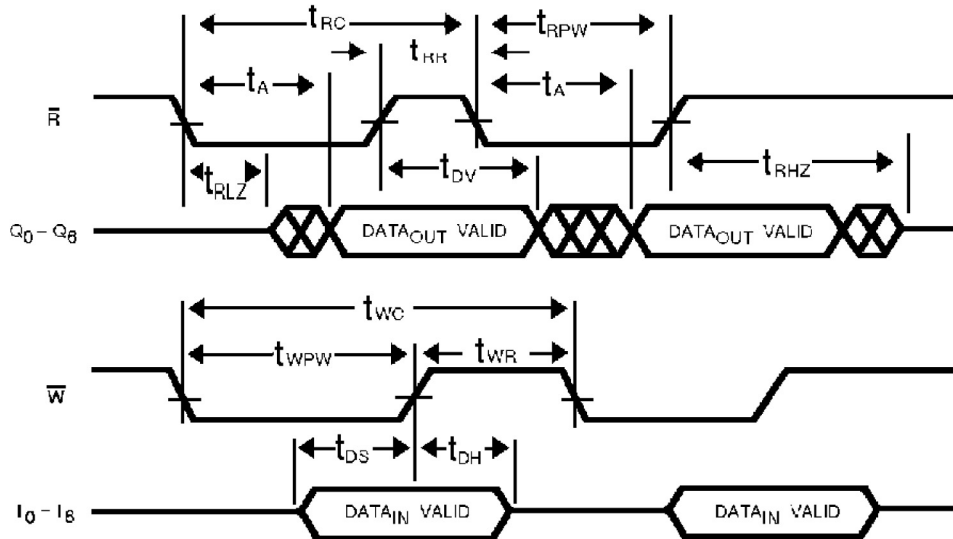

Figure 9. Full Flag from Last Write to First Read

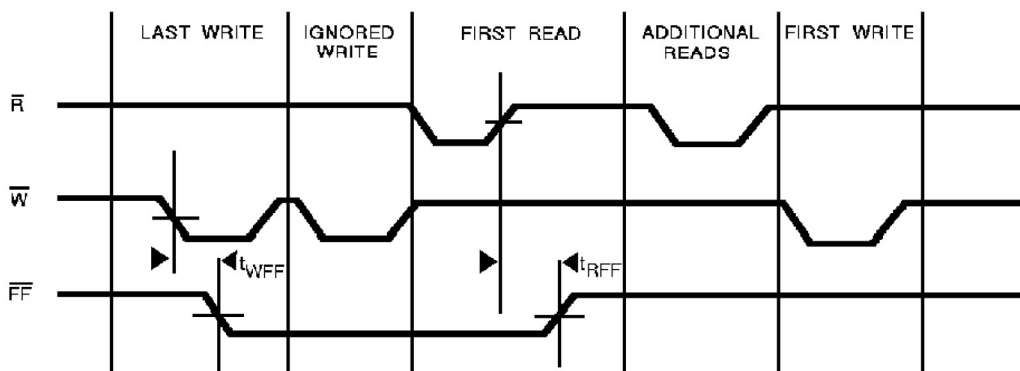

Figure 10. Empty Flag from Last Read to First Write

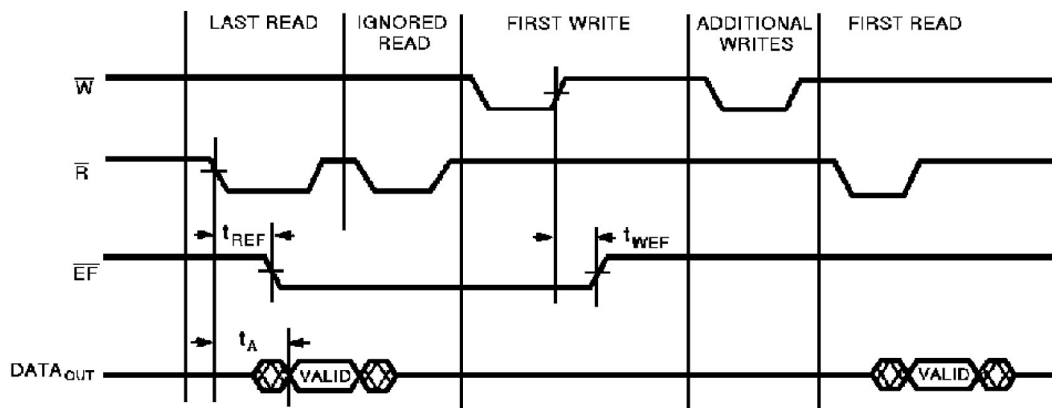

Figure 11. Retransmit

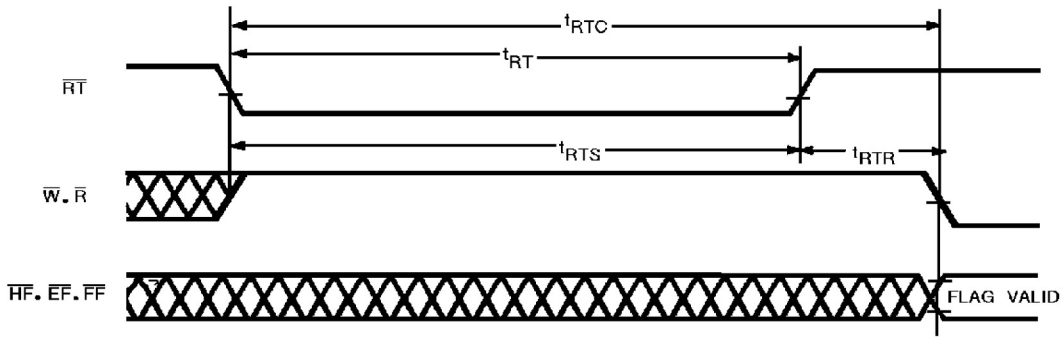

Figure 12. Empty Flag Timing

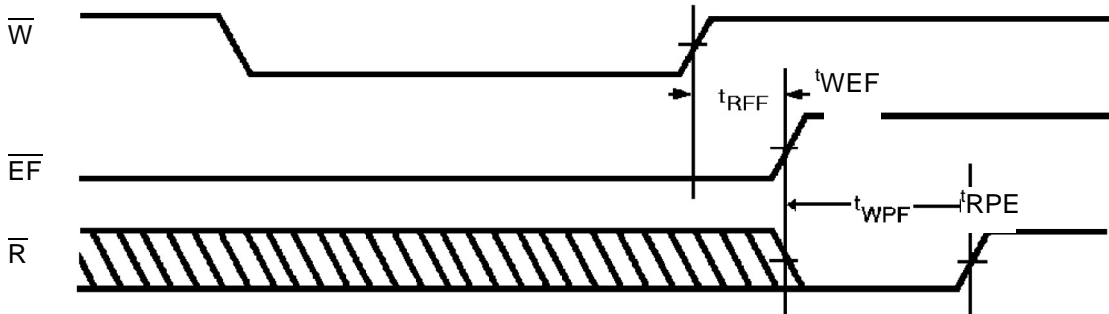

Figure 13. Full Flag Timing

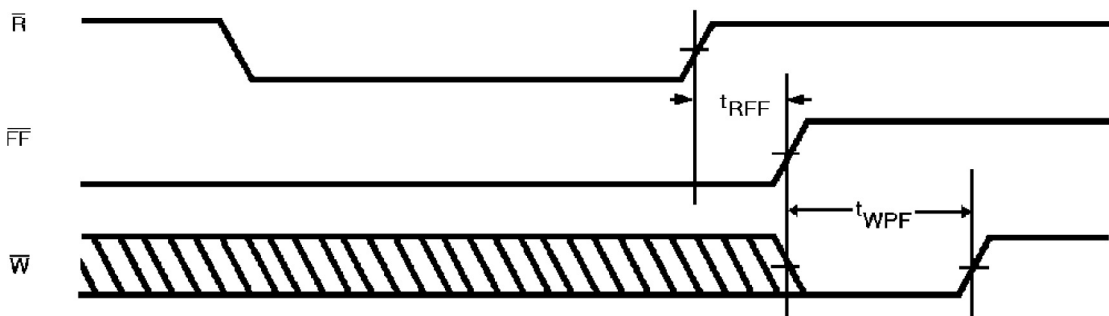

Figure 14. Half-Full Flag Timing

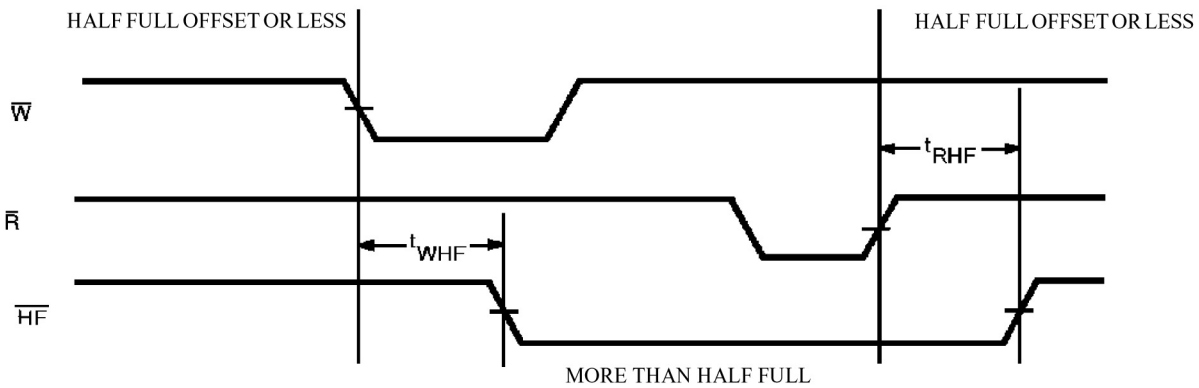

Figure 15. Expansion Out

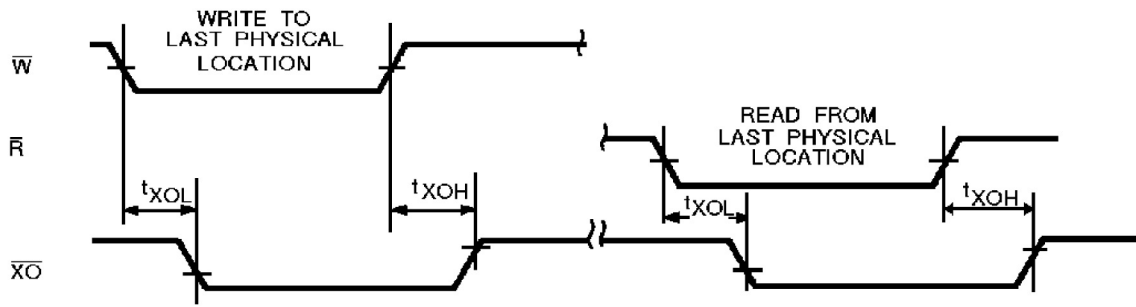

Figure 16. Expansion In

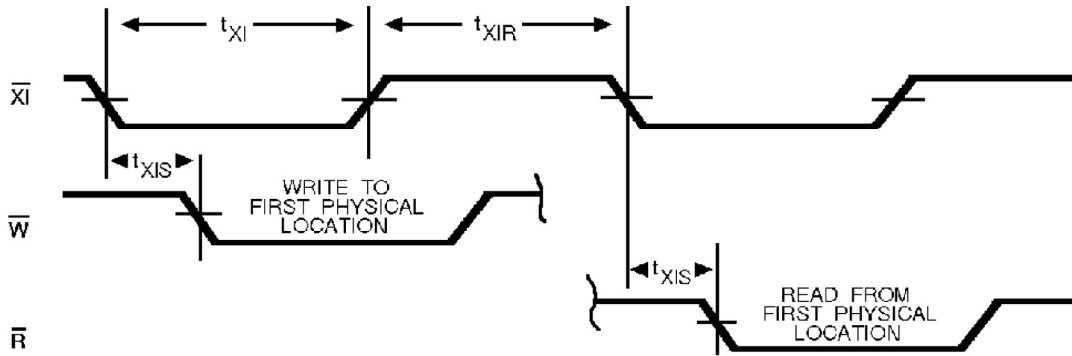

Figure 17. Read Data Flow - Through Mode

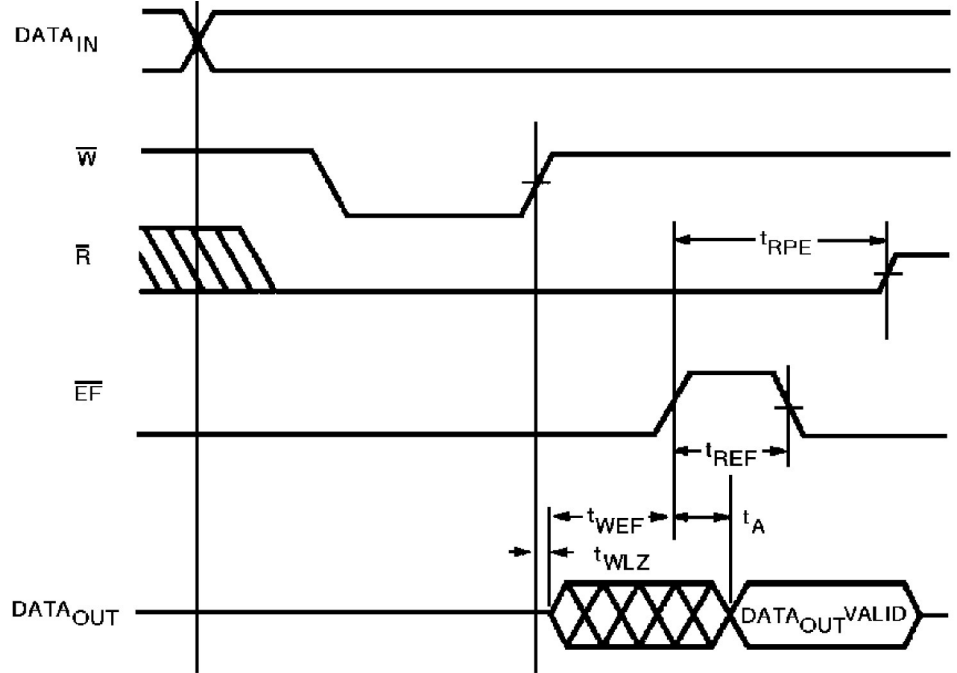
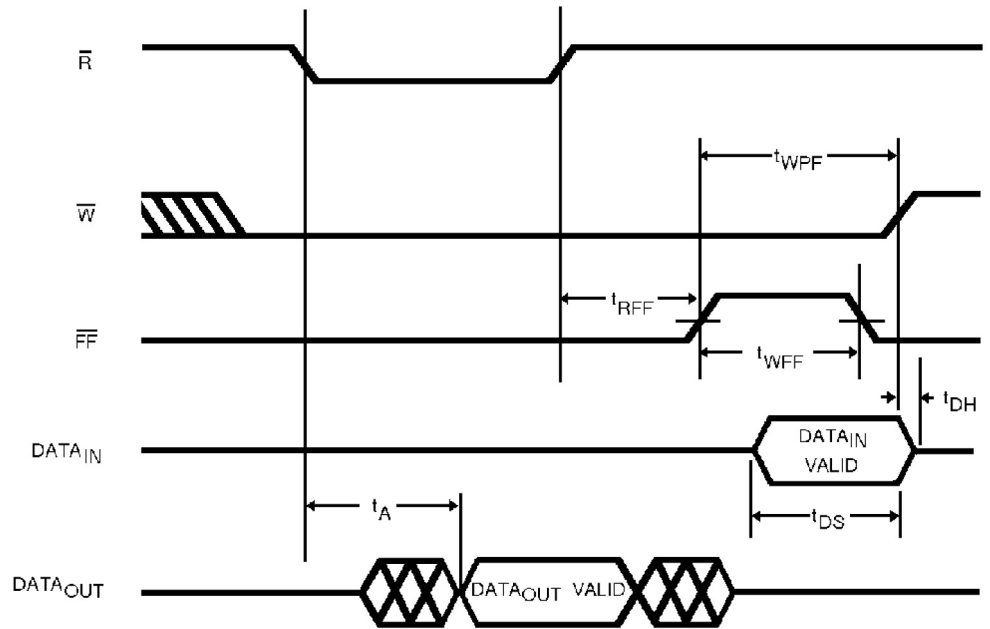

Figure 18. Write Data Flow - Through Mode



Ordering Information

Reference Number	Temperature Range	Speed	Package	Quality Flow
MMCP-67204HV-15-E ⁽¹⁾	25°C	15 ns	SB28.3	Engineering Samples
MMCP-67204HV-15	-55 to +125°C	15 ns	SB28.3	Standard Mil.
MMCP-67204HV-30	-55 to +125°C	30 ns	SB28.3	Standard Mil.
SMCP-67204HV-15SB	-55 to +125°C	15 ns	SB28.3	SCC B
SMCP-67204HV-30SB	-55 to +125°C	30 ns	SB28.3	SCC B
5962-8956810QTC	-55 to +125°C	15 ns	SB28.3	QML Q
5962-8956809QTC	-55 to +125°C	30 ns	SB28.3	QML Q
5962-8956810VTC	-55 to +125°C	15 ns	SB28.3	QML V
5962-8956809VTC	-55 to +125°C	30 ns	SB28.3	QML V
5962D8956810VTC	-55 to +125°C	15 ns	SB28.3	QML V RHA
5962D8956809VTC	-55 to +125°C	30 ns	SB28.3	QML V RHA
MMDP-67204HV-15-E	25°C	15 ns	FP28.4	Engineering Samples
MMDP-67204HV-15	-55 to +125°C	15 ns	FP28.4	Mil.
MMDP-67204HV-30	-55 to +125°C	30 ns	FP28.4	Mil.
SMDP-67204HV-15SB	-55 to +125°C	15 ns	FP28.4	SCC B
SMDP-67204HV-30SB	-55 to +125°C	30 ns	FP28.4	SCC B
5962-8956810QNC	-55 to +125°C	15 ns	FP28.4	QML Q
5962-8956809QNC	-55 to +125°C	30 ns	FP28.4	QML Q
5962-8956810VNC	-55 to +125°C	15 ns	FP28.4	QML V
5962-8956809VNC	-55 to +125°C	30 ns	FP28.4	QML V
5962D8956810VNC	-55 to +125°C	15 ns	FP28.4	QML V RHA
5962D8956809VNC	-55 to +125°C	30 ns	FP28.4	QML V RHA
MM0 -67204HV-15-E ⁽¹⁾	25°C	15 ns	Die	Engineering Samples
5962-8956810Q9A ⁽¹⁾	-55 to +125°C	15 ns	Die	QML Q
5962-8956810V9A ⁽¹⁾	-55 to +125°C	15 ns	Die	QML V

Note: 1. Contact Atmel for availability.

Package Drawings

28-lead Side Braze 300 mils

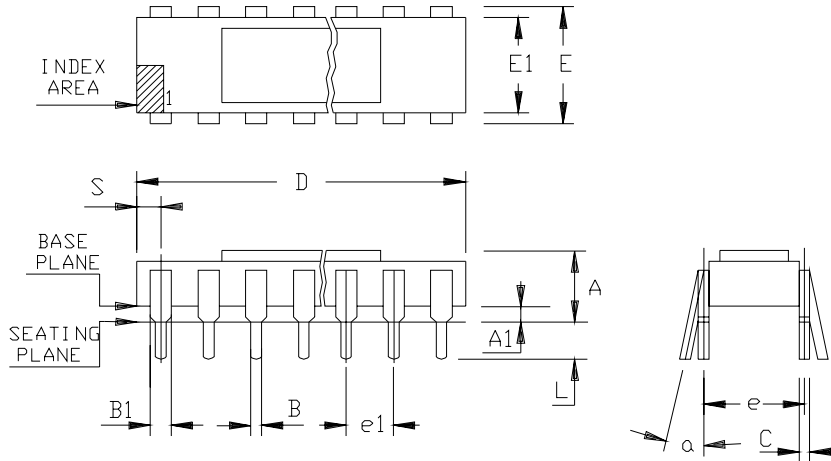

	MM		INCH	
	A	2.82	3.94	.111
A1	0.63	1.14	.025	.045
B	0.38	0.53	.015	.021
B1	0.96	1.52	.038	.060
C	0.20	0.30	.008	.012
D	27.43	28.45	1.080	1.120
E	7.49	8.25	.295	.325
E1	7.11	7.87	.280	.310
L	3.18	4.44	.125	.175
S	1.10	2.03	.043	.080
e	7.62	TYP	.300	TYP
e1	2.54	TYP	.100	TYP
α	0°		15°	

28-lead Flat Pack (400 mils)

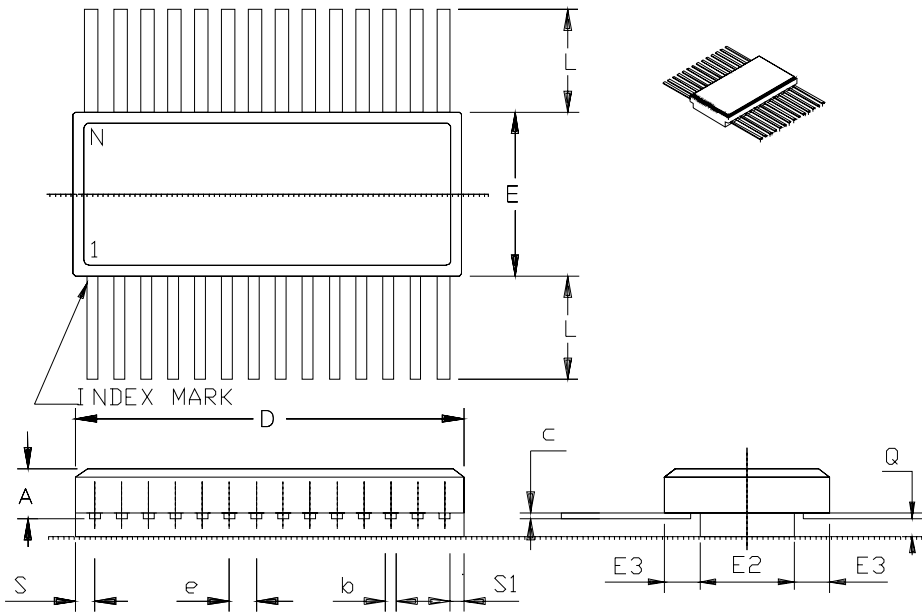

	MM		INCH	
	Min	Max	Min	Max
A	2.29	3.30	.090	.130
b	0.38	0.48	.015	.019
c	0.08	0.15	.003	.006
D	---	18.80	---	.740
E	9.65	10.67	.380	.420
E2	4.57	---	.180	---
E3	0.76	---	.030	---
e	1.27 BSC		.050 BSC	
L	6.35	9.40	.250	.370
Q	0.66	---	.026	---
S	---	1.30	---	.051
S1	0.00	---	.000	---
N	28		28	



Atmel Corporation

2325 Orchard Parkway
San Jose, CA 95131, USA
Tel: 1(408) 441-0311
Fax: 1(408) 487-2600

Regional Headquarters

Europe

Atmel Sarl
Route des Arsenalux 41
Case Postale 80
CH-1705 Fribourg
Switzerland
Tel: (41) 26-426-5555
Fax: (41) 26-426-5500

Asia

Room 1219
Chinachem Golden Plaza
77 Mody Road Tsimshatsui
East Kowloon
Hong Kong
Tel: (852) 2721-9778
Fax: (852) 2722-1369

Japan

9F, Tonetsu Shinkawa Bldg.
1-24-8 Shinkawa
Chuo-ku, Tokyo 104-0033
Japan
Tel: (81) 3-3523-3551
Fax: (81) 3-3523-7581

Atmel Operations

Memory

2325 Orchard Parkway
San Jose, CA 95131, USA
Tel: 1(408) 441-0311
Fax: 1(408) 436-4314

Microcontrollers

2325 Orchard Parkway
San Jose, CA 95131, USA
Tel: 1(408) 441-0311
Fax: 1(408) 436-4314

La Chantrerie
BP 70602
44306 Nantes Cedex 3, France
Tel: (33) 2-40-18-18-18
Fax: (33) 2-40-18-19-60

ASIC/ASSP/Smart Cards

Zone Industrielle
13106 Rousset Cedex, France
Tel: (33) 4-42-53-60-00
Fax: (33) 4-42-53-60-01

1150 East Cheyenne Mtn. Blvd.
Colorado Springs, CO 80906, USA
Tel: 1(719) 576-3300
Fax: 1(719) 540-1759

Scottish Enterprise Technology Park
Maxwell Building
East Kilbride G75 0QR, Scotland
Tel: (44) 1355-803-000
Fax: (44) 1355-242-743

RF/Automotive

Theresienstrasse 2
Postfach 3535
74025 Heilbronn, Germany
Tel: (49) 71-31-67-0
Fax: (49) 71-31-67-2340

1150 East Cheyenne Mtn. Blvd.
Colorado Springs, CO 80906, USA
Tel: 1(719) 576-3300
Fax: 1(719) 540-1759

Biometrics/Imaging/Hi-Rel MPU/ High Speed Converters/RF Datacom

Avenue de Rochepleine
BP 123
38521 Saint-Egreve Cedex, France
Tel: (33) 4-76-58-30-00
Fax: (33) 4-76-58-34-80

Literature Requests

www.atmel.com/literature

Disclaimer: Atmel Corporation makes no warranty for the use of its products, other than those expressly contained in the Company's standard warranty which is detailed in Atmel's Terms and Conditions located on the Company's web site. The Company assumes no responsibility for any errors which may appear in this document, reserves the right to change devices or specifications detailed herein at any time without notice, and does not make any commitment to update the information contained herein. No licenses to patents or other intellectual property of Atmel are granted by the Company in connection with the sale of Atmel products, expressly or by implication. Atmel's products are not authorized for use as critical components in life support devices or systems.

© Atmel Corporation 2004. All rights reserved. Atmel® and combinations thereof are the registered trademarks of Atmel Corporation or its subsidiaries. Other terms and product names may be the trademarks of others.



Printed on recycled paper.