

## Features

- Secure Computation of Public Key Signatures
- Secure Storage and Decryption of Symmetric Keys
- On-chip Cache for Frequently Used Keys
- SMBus Communications Port
- On-board Public Key Computation Engine and Microprocessor
- Physical and Logical Security Measures to Inhibit Attacks
- 20-lead SOIC Package, 0°C to +70°C Operating Range
- 3.3V ±10% Supply Voltage

## Description

The AT90SP0801 is used to perform cryptographic operations, using asymmetric private keys stored in its internal EEPROM. An arbitrary number of private keys can be stored externally and decrypted by the chip when required. Communication to the system processor is via the SMBus.

Figure 1. Pin Configuration

Name	Description
$\overline{\text{RESET}}$	Reset Input, Active-low
SCL	SMBus Clock
SDA	SMBus Data
GND	Ground
CLKIN	Input Clock
VCC	Operating Voltage
TEST	Do Not Connect

28-lead TSSOP

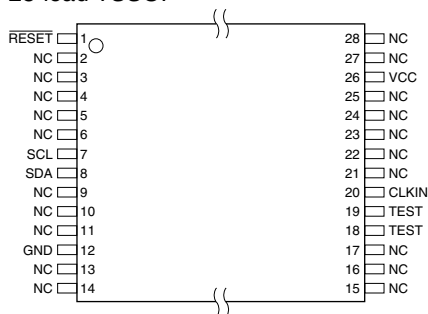

28-lead SOIC

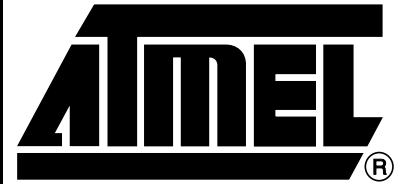
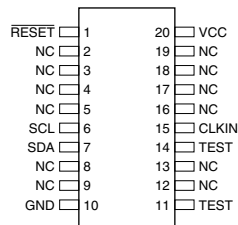

## Secure Signature Generation Chip

### AT90SP0801

## Summary

Rev. 1495AS-01/02



Note: This is a summary document. A complete document is available under NDA. For more information, please contact your local Atmel sales office.

Figure 2. Block Diagram

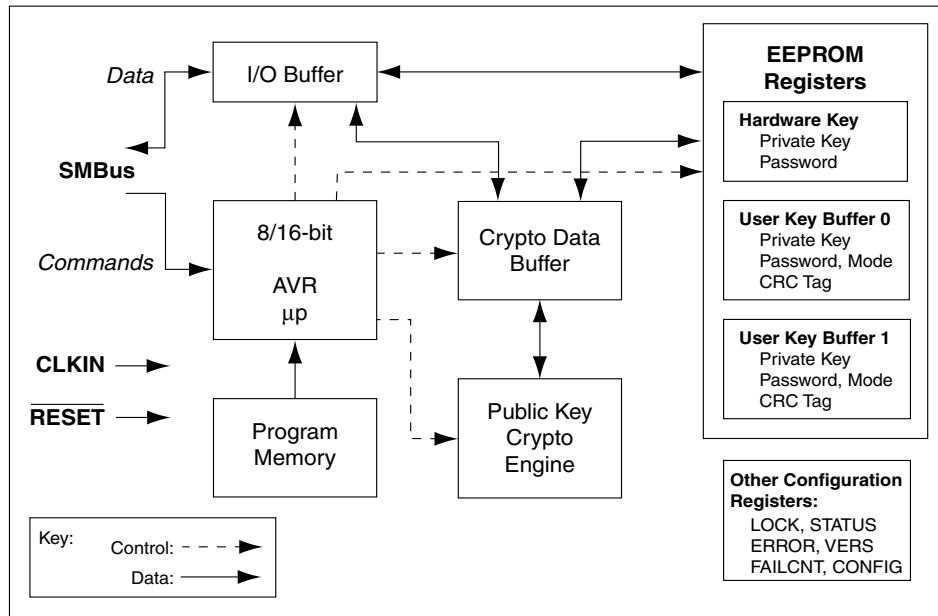

## Serial Interface

Data is transferred to or from the I/O buffer on the chip using the SMBus interface, in a manner similar but not identical to that of standard two-wire serial EEPROMs.

All bits are sent to or read from the chip most significant bit first, in a manner consistent with standard serial EEPROMs. Bit fields listed in this document are correspondingly listed with the MSB on the left and the LSB on the right. Hex numbers are specified with the “0x” prefix.

Multi-byte information sent to the chip is sent most significant byte first, following typical conventions. Within the chip, the first byte sent to the chip is stored in memory at the lowest address, and the address is incremented for subsequent bytes. When a message digest (hash) is sent to the chip, the first byte of the hash value is the first byte to be sent to the chip.

In both the text and graphics, the chip is the slave and the system is the master. The following abbreviations apply:

- A** Acknowledge (bus pulled low, master or slave)
- N** Not Acknowledge (bus left high, master or slave)
- S** Start (High-to-low on SDA with SCL high, master)
- P** Stop (Low-to-high on SDA with SCL high, master)

For the graphical representations, the direction of the data flow is indicated as below:

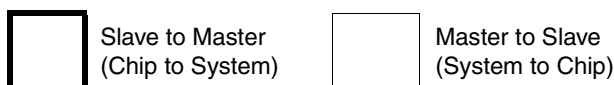

## SMBus Standard Usage

Data transfer to and from the chip follows the SMBus V1.1 standard, using only some of the command protocols.

The “write” command of this chip uses the “Block Write” protocol of the SMBus spec. Note that in this chip the count value can exceed 32. This chip does not support the “Write Byte” and “Write Word” protocols of the SMBus spec.

The “Read” command of this chip uses the “Block Read” protocol of the SMBus spec. Note that in this chip the “Read” command can be optionally executed without the preceding partial block write command. This chip does not support the “Receive Byte”, “Read Byte” and “Read Word” protocols of the SMBus spec.

All other commands of this chip use the “Send Byte” protocol of the SMBus spec. Note that the “Quick Command” and “Process Call” protocols of the SMBus spec are not supported by this chip.

## Two-wire Serial EEPROM Comparison

Some of the differences between this chip and a standard two-wire serial EEPROM are:

1. The slave address of this chip is different from the A0-AF (hex) standard for EEPROMs.
2. The maximum clock rate is 100 kHz and T<sub>dh</sub> is 300 ns. These specs are part of SMBus.
3. The supply voltage is 3.0V to 3.7V.
4. The read address is not specified in the aborted read command.
5. Multi-byte reads and writes are preceded by the number of bytes that will be transferred.

- Multi-byte writes longer than the maximum size of the register (i.e., containing more bytes) cause an error.

### Commands Without Data Transfer

There are a number of commands (described within the following Commands sections) that perform various internal operations on the chip, using data already stored in either the I/O buffer or the internal memories of the chip. All such commands are composed of two bytes sent to the chip according to the following flow:

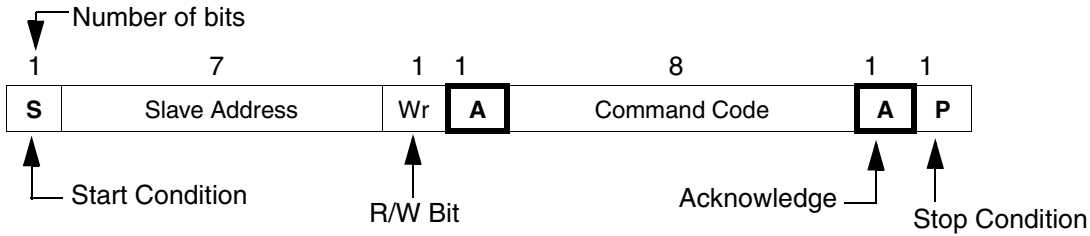

### Write Commands

The write commands permit data to be transferred to the I/O buffer located within the SRAM on the chip. Only block writes are supported, so transfers of 1 or 2 bytes require the same basic sequence as 32 bytes.

The commands are encoded as follows:

Slave Address	Command Code	Description
0 1 0 1 0 0 0 0	$s_1 s_0 0 0 0 0 0 0$	Write buffer, (+data)
0 1 0 1 0 0 1 0	0 1 1 1 1 1 1 1	Write command, ignored
0 1 0 1 0 0 0 0	0 1 1 1 1 1 1 1	Write command, ignored

The following figure shows the structure for block write operations:

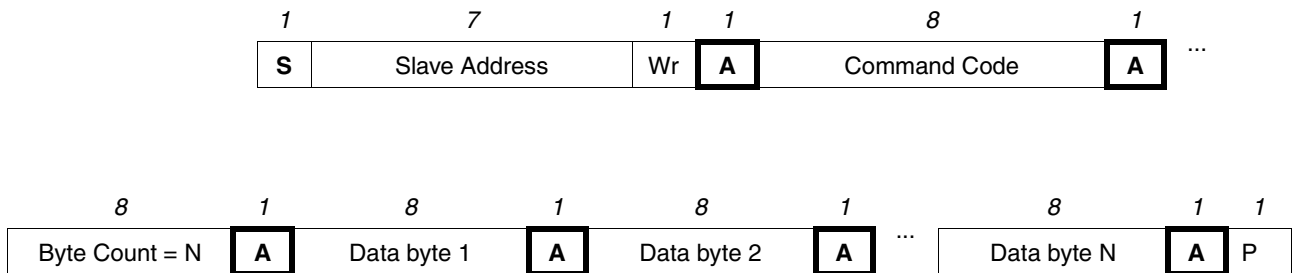

The write buffer command is followed by up to 255 bytes of data. All bytes are sourced by the host and are formatted as follows:

01010000	$s_1 s_0 0 0 0 0 0 0$	count	data0	data1	...	dataN	crc0	crc1
----------	-----------------------	-------	-------	-------	-----	-------	------	------

**Count** denotes the total number of bytes that follows the command, including any CRC bytes. A 0 value is illegal. 255 is the max. number of bytes that may be written per command.

**Data** is sent least significant byte first. In some circumstances, there may be no *data*, only *crc*.

Depending on the value of *ss*, the *crc* bytes may or may not be included.

The two sequence bits  $s_{1-0}$  within the command code tell the chip how to relate this transfer to previous and subsequent transfers.

$S_0$  if set to a 1 indicates that this is the first transfer to the buffer and that *data0* should go into buffer address 0 and so on. If this bit is set to a 0, then *data0* will be stored in the next location within the buffer after that from the previous transfer. When set, this bit also resets the CRC generator.

$S_1$  if set to a 1 indicates that this is the last transfer to the buffer. If set to a 0, the chip must have previously executed a command where  $s_0$  was set to a 1. When  $s_1$  is set to a 1, the last two bytes of the information transferred in this block are a CRC value. The chip will NACK the *crc1* byte, if the value sent does not match that computed on the incoming data. The CRC bytes may not be split across two blocks.

For instance, to write password information (64 bytes) to the chip, the following sequence of three write commands would be used (assuming 32 byte loads). The ACKs, NACKs and STOP conditions have been ignored for clarity.

<b>S</b>	01010000	01000000	00100000	data0	data1	data2	...	data31
<b>S</b>	01010000	00000000	00100000	data32	data33	data34	...	data63
<b>S</b>	01010000	10000000	00000010	crc0	crc1			

For shorter data transfer values, it is perfectly legal for both  $s_0$  and  $s_1$  to be set. This indicates that the entire transfer is taking place in a single block access. As an example of this, the following command would write a single byte to the buffer:

<b>S</b>	01010000	11000000	00000011	data0	crc0	crc1
----------	----------	----------	----------	-------	------	------

The chip will NACK writes that attempt to write into the chip beyond the internal buffer, which may be as short as 320 bytes.



## Read Commands

Block read commands are slightly different than writes and are encoded as follows:

Slave Address	Command Code	Description
0 1 0 1 0 0 1 1	- - - - - - -	Read buffer, first block
0 1 0 1 0 0 0 1	- - - - - - -	Read, subsequent blk

The read command is only one byte long, and the chip (not the host) sends back the count information. The count value will always be the smaller of MAXBLK\_R or the (remaining) number of bytes in the register that have not been read yet.

When there are a large number of bytes in the buffer, multiple read commands must be executed to read all the bytes out of the chip. Using the slave address of 0x53 will cause the chip to start reading at the beginning of the buffer. Using the slave address of 0x51 will cause the chip to continue reading information that is subsequent to the information last read by the chip from the buffer. After a load or crypto operation, the first command may also be a 0x51, which will have the same effect as 0x53.

Block Reads are formatted as follows:

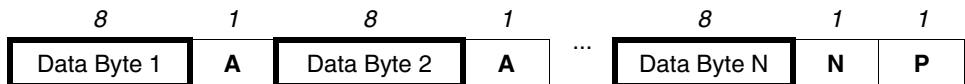
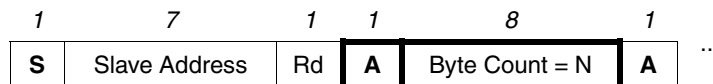

After the last byte has been read from the register, the read pointer is reset back to the beginning of the register, and the system may continue to read from the beginning of the buffer again, if desired. There is no indication from the chip as to when the read pointer has been reset (other than as may be inferred from the values in the count field).

To be compatible with the SMBus specification, the read command may optionally be preceded by the first two bytes of either of the “ignored write” commands, which are then aborted with a new start bit for the read. The two bytes of the write command are completely ignored by the chip in this case, and a different encoding for the second byte (01111111, or 0x7F) must be used. Execution of a block read sequence using a legal write command code for the second byte (00, 0x40, 0x80 or 0xC) is undefined.

The protocol for this is shown below:

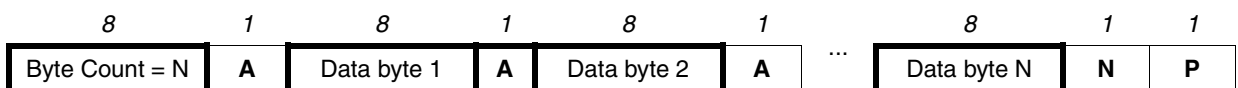
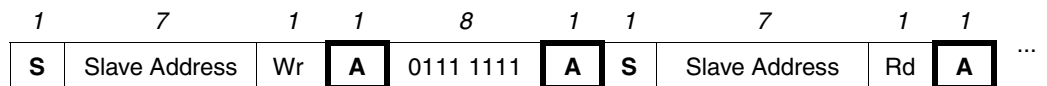

As an example of the read block command, the following would take place to read four bytes of data from the buffer (assuming that the load VERS\_R command had previously been executed).

<b>S</b>	01010011	00000100	data0	data1	data2	data3
----------	----------	----------	-------	-------	-------	-------

or

<b>S</b>	01010010	01111111	<b>S</b>	01010011	00000100	data0	data1	data2	data3
----------	----------	----------	----------	----------	----------	-------	-------	-------	-------

As an example of multiple read block command, the following would take place to read the 1040 bits (130 bytes) of signature data from the buffer (assuming that the “sign” command had previously been executed). As earlier, the two-byte aborted write is an option on each command. Note that the first byte read (data0) is the most significant byte of the signature, while data128 is the most significant byte of the CRC.

<b>S</b>	01010010	01111111	<b>S</b>	01010011	00100000	data0	data1	...	data31
<b>S</b>	01010000	01111111	<b>S</b>	01010001	00100000	data32	data33	...	data63
<b>S</b>	01010000	01111111	<b>S</b>	01010001	00100000	data64	data65	...	data95
<b>S</b>	01010000	01111111	<b>S</b>	01010001	00100000	data96	data97	...	data127
<b>S</b>	01010000	01111111	<b>S</b>	01010001	00000010	data128	data129	...	

## Absolute Maximum Ratings

Operating Temperature.....	0°C to +70°C
Storage Temperature (without bias).....	0°C to +70°C
Voltage on I/O Pins.....	-0.1 to $V_{CC} + 0.3V$
Voltage on VCC with Respect to Ground.....	6.0V
Maximum ESD Voltage.....	2000V

**\*NOTICE:** Stresses beyond those listed under “Absolute Maximum Ratings” may cause permanent damage to the device. This is a stress rating only and functional operation of the device at these or any other conditions beyond those indicated in the operational sections of this specification may cause temporary or permanent failure. Exposure to absolute maximum rating conditions for extended periods may affect device reliability.

## Serial Interface AC Specifications

$C_L = 1$  TTL Gate and 100 pF, except as noted.  $V_{CC} = 3.0V$  to 3.7V.

Name	Min	Max	Units	Notes
$t_{SCL}$		100	kHz	Clock (SCL) Frequency
$t_{LOW}$	4.7		$\mu s$	Clock (SCL) Pulse Low-width
$t_{HIGH}$	4.0		$\mu s$	Clock (SCL) Pulse High-width
$t_I$		100	ns	Noise Suppression, Not Tested
$t_{AA}$	0.1	4.5	$\mu s$	Clock low to Data out valid
$t_{BUF}$	4.7		$\mu s$	Bus free before Transmission, Not Tested
$t_{HD,STA}$	4.0		$\mu s$	Start Hold Time
$t_{SU,STA}$	4.7		$\mu s$	Start Set-up Time
$t_{HD,DAT}$	0		$\mu s$	Data In Hold Time
$t_{SU,DAT}$	200		ns	Data In Set-up Time
$t_R$		1.0	$\mu s$	Inputs Rise Time, Not Tested
$t_F$		300	ns	Inputs Fall time, Not Tested
$t_{SU,STO}$	4.7		$\mu s$	Stop Set-up Time
$t_{DH}$	300		ns	Data Out Hold Time
$t_{WR}$		10	ms	Write Cycle Time, EEPROM Write
$t_{CLKIN}$	69	100	ns	CLKIN Period
$t_{CLKO}, t_{CKH1}$	34	50	ns	CLKIN Low or CLKIN High

**Figure 3.** Timing Diagram for Serial Interface AC Specification

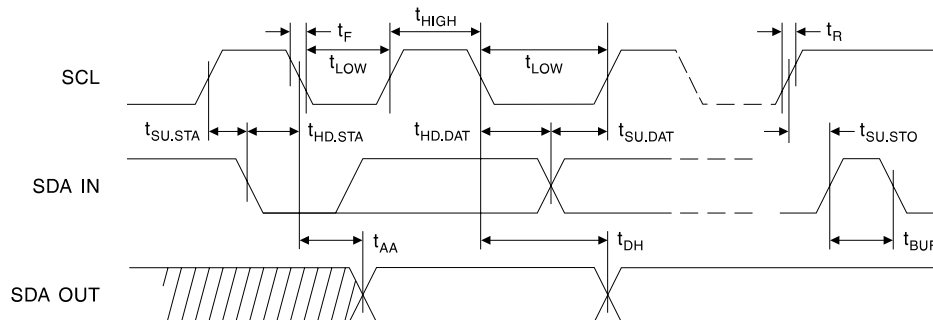



## Serial Interface DC Specifications

Operating Temperature Range = 0° to 70°C.

Name	Min	Typ	Max	Units	Notes
V <sub>CC</sub>	3.0		3.7	V	Operating Voltage, V <sub>CC</sub> Pin
I <sub>CC</sub> <sup>(1)</sup>		18	25	mA	At V <sub>CC</sub> = 3.7V, f <sub>SDA</sub> = 100 kHz
I <sub>SB</sub> <sup>(1)</sup>		50	100	μA	At V <sub>CC</sub> = 3.3V, CLKIN = V <sub>SS</sub>
I <sub>LIO</sub>		0.1	3.0	μA	SDA, SCL. V <sub>IN</sub> = V <sub>CC</sub> or V <sub>SS</sub>
V <sub>IL</sub>	-0.1		V <sub>CC</sub> x 0.3	V	
V <sub>IH</sub>	V <sub>CC</sub> x 0.7		V <sub>CC</sub>	V	
V <sub>OL</sub>			0.4	V	I <sub>OL</sub> = 2.1 mA
C <sub>IO</sub>				pF	SCL, SDA, Not Tested
f <sub>CLKIN</sub>	1	14.318	15	MHz	Duty cycle >48% and <52%

- Notes:
1. The specifications noted as "not tested" denote parameters that are characterized and not 100% tested.
  2. Preliminary data, subject to change.



## Ordering Information

Ordering Code	Package	Operation Range
AT90SP0801-01SC	20S, 20-lead SOIC	Commercial (0°C to 70°C)

Package Type	
20S	20-lead, 0.300 Wide, Plastic Gull Wing Small Outline (SOIC)



## Packaging Information

**20S**, 20 Lead, 0.300" Wide,  
Plastic Gull Wing Small Outline (SOIC)  
Dimensions in Inches and (Millimeters)

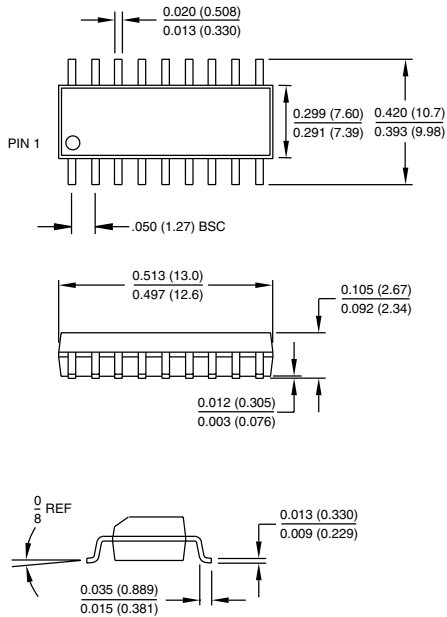

**28A**, 28-lead, 6.1mm Wide, Thin Shrink Small  
Outline Package (TSSOP)  
Dimensions in Inches and (Millimeters)

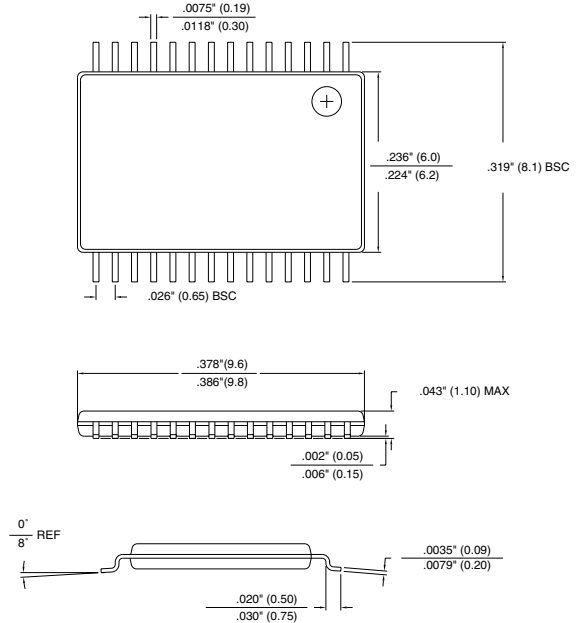



## Atmel Headquarters

**Corporate Headquarters**  
2325 Orchard Parkway  
San Jose, CA 95131  
TEL 1(408) 441-0311  
FAX 1(408) 487-2600

### Europe

Atmel SarL  
Route des Arsenaux 41  
Casa Postale 80  
CH-1705 Fribourg  
Switzerland  
TEL (41) 26-426-5555  
FAX (41) 26-426-5500

### Asia

Atmel Asia, Ltd.  
Room 1219  
Chinachem Golden Plaza  
77 Mody Road Tsimhatsui  
East Kowloon  
Hong Kong  
TEL (852) 2721-9778  
FAX (852) 2722-1369

### Japan

Atmel Japan K.K.  
9F, Tonetsu Shinkawa Bldg.  
1-24-8 Shinkawa  
Chuo-ku, Tokyo 104-0033  
Japan  
TEL (81) 3-3523-3551  
FAX (81) 3-3523-7581

## Atmel Operations

### Memory

Atmel Corporate  
2325 Orchard Parkway  
San Jose, CA 95131  
TEL 1(408) 436-4270  
FAX 1(408) 436-4314

### Microcontrollers

Atmel Corporate  
2325 Orchard Parkway  
San Jose, CA 95131  
TEL 1(408) 436-4270  
FAX 1(408) 436-4314

Atmel Nantes  
La Chantrerie  
BP 70602  
44306 Nantes Cedex 3, France  
TEL (33) 2-40-18-18-18  
FAX (33) 2-40-18-19-60

### ASIC/ASSP/Smart Cards

Atmel Rousset  
Zone Industrielle  
13106 Rousset Cedex, France  
TEL (33) 4-42-53-60-00  
FAX (33) 4-42-53-60-01

Atmel Colorado Springs  
1150 East Cheyenne Mtn. Blvd.  
Colorado Springs, CO 80906  
TEL 1(719) 576-3300  
FAX 1(719) 540-1759

Atmel Smart Card ICs  
Scottish Enterprise Technology Park  
Maxwell Building  
East Kilbride G75 0QR, Scotland  
TEL (44) 1355-803-000  
FAX (44) 1355-242-743

### RF/Automotive

Atmel Heilbronn  
Theresienstrasse 2  
Postfach 3535  
74025 Heilbronn, Germany  
TEL (49) 71-31-67-0  
FAX (49) 71-31-67-2340

Atmel Colorado Springs  
1150 East Cheyenne Mtn. Blvd.  
Colorado Springs, CO 80906  
TEL 1(719) 576-3300  
FAX 1(719) 540-1759

### Biometrics/Imaging/Hi-Rel MPU/ High Speed Converters/RF Datacom

Atmel Grenoble  
Avenue de Rochepleine  
BP 123  
38521 Saint-Egreve Cedex, France  
TEL (33) 4-76-58-30-00  
FAX (33) 4-76-58-34-80

---

### *e-mail*

[literature@atmel.com](mailto:literature@atmel.com)

### *Web Site*

<http://www.atmel.com>

### © Atmel Corporation 2002.

Atmel Corporation makes no warranty for the use of its products, other than those expressly contained in the Company's standard warranty which is detailed in Atmel's Terms and Conditions located on the Company's web site. The Company assumes no responsibility for any errors which may appear in this document, reserves the right to change devices or specifications detailed herein at any time without notice, and does not make any commitment to update the information contained herein. No licenses to patents or other intellectual property of Atmel are granted by the Company in connection with the sale of Atmel products, expressly or by implication. Atmel's products are not authorized for use as critical components in life support devices or systems.

ATMEL® is the registered trademarks of Atmel.



Printed on recycled paper.

1495AS-01/02/xM