

Features

- Operating with Single 5V or 12V Input
- Drives N-Channel MOSFETs
- Simple Single-Loop Control Design
 - Voltage-Mode PWM Control
 - Full 0% to 100% Duty Ratio
 - Fast Transient Response
- $\pm 2\%$ Output Voltage Accuracy Over Temperature
- Under-Voltage Protection for Output
- 200/400kHz Constant Frequency Operation
 - 200kHz for APW7037 & APW7037B
 - 400kHz for APW7037A
- Small size, 8-PIN Package (SOIC or TSSOP)
- Lead Free Available (RoHS Compliant)

Applications

- Graphics Cards
- DDR Memory Power Supply
- DDR Memory Termination Voltage
- Low-Voltage Distributed Power Supplies

General Description

The APW7037 series are designed to provide a low cost synchronous Buck regulator for on-board DC to DC converter applications. The APW7037 series together with dual N-channel MOSFETs such as APM7313, provide a low cost solution for such applications. Each device features an internal 200/400kHz oscillator, Power-On-Reset (POR) for both VCC and VC supplies, an external programmable soft-start function as well as output under-voltage detection that latches off the device when an output short is detected.

Pin Description

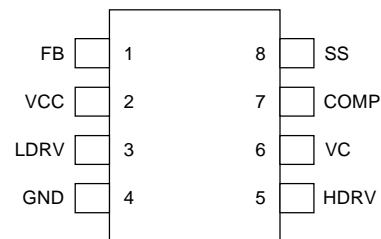

Ordering and Marking Information

<p>APW7037/A/B <input type="checkbox"/> <input type="checkbox"/> - <input type="checkbox"/> <input type="checkbox"/> <input type="checkbox"/></p> <p>Lead Free Code Handling Code Temp. Range Package Code</p>	<p>Package Code K : SO-8 R : TSSOP-8 Operating Junction Temp. Range C : 0 to 70°C Handling Code TU : Tube TR : Tape & Reel Lead Free Code L : Lead Free Device Blank : Original Device</p>
<p>APW7037/A/B K : APW7037/A/B XXXXX</p>	<p>XXXXX - Date Code</p>
<p>APW7037/A/B R :  APW7037/A/B XXXXX</p>	<p>XXXXX - Date Code</p>

Notes: ANPEC lead-free products contain molding compounds/die attach materials and 100% matte in plate termination finish; which are fully compliant with RoHS and compatible with both SnPb and lead-free soldering operations. ANPEC lead-free products meet or exceed the lead-free requirements of IPC/JEDEC J STD-020C for MSL classification at lead-free peak reflow temperature.

Block Diagram

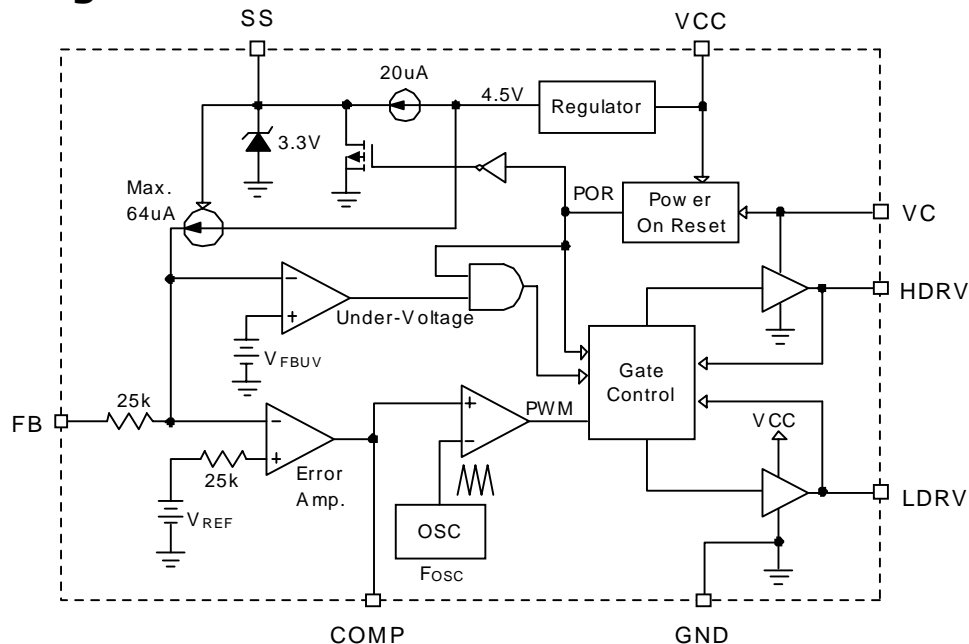

Absolute Maximum Ratings

Description	Rating	Unit
VCC to GND	-0.2~30	V
VC to GND	-0.2~30	V
Operating Junction Temperature	0~125	°C
Storage Temperature	-65~150	°C
Soldering Temperature (10 Seconds)	300	°C
Minimum ESD Rating	±2	kV

Thermal Characteristics

Symbol	Parameter	Value	Unit
θ_{JA}	Thermal Resistance in Free Air		
	8-pin SOIC	160	°C/W
	8-pin TSSOP	124	

Electrical Characteristics

Unless otherwise specified, these specifications apply over VCC=5V, VC=12V and TA=0 to 70°C. Typical values refer to TA=25°.

Symbol	Parameter	Test Conditions	APW7037/A/B			Unit
			Min.	Typ.	Max.	
SUPPLY CURRENT						
I _{CC}	VCC Dynamic Supply Current	F _{OSC} =200KHz, C _L =1500pF	2	3	5	mA
I _C	VC Dynamic Supply Current	F _{OSC} =200KHz, C _L =1500pF	2	5.5	8	mA
I _{CCQ}	VCC Static Supply Current	SS=GND	0.5	1.5	3	mA
I _{CQ}	VC Static Supply Current	SS=GND	0.2	0.4	1	mA
POWER-ON RESET						
	Rising VCC Threshold		4.0	4.2	4.4	V
	VCC POR Hysteresis			0.25		V
	Rising VC Threshold		3.1	3.3	3.5	V
	VC POR Hysteresis			0.2		V
OSCILLATOR						
F _{OSC}	Free Running Frequency	APW7037	180	200	220	KHz
		APW7037A	360	400	440	
		APW7037B	180	200	220	
ΔV_{OSC}	Ramp Amplitude			1.10		V
ERROR AMPLIFIER						
I _{FB1}	FB Pin Input Bias Current	SS=3V, V _{FB} =1V		1		nA
I _{FB2}	FB Pin Input Bias Current	SS=0V, V _{FB} =1V		-64		μA
GM	Transconductance		450	600	750	μmho
REFERENCE VOLTAGE						
V _{FB}	FB Pin Regulation Voltage	APW7037	1.225	1.250	1.275	V
		APW7037A	0.784	0.800	0.816	
		APW7037B	0.784	0.800	0.816	
LREG	V _{FB} Line Regulation	VCC = 5~12V		0.2	0.35	%

Electrical Characteristics (Cont.)

Unless otherwise specified, these specifications apply over VCC=5V, VC=12V and TA=0 to 70°C. Typical values refer to TA=25°C.

Symbol	Parameter	Test Conditions	APW7037/A/B			Unit	
			Min.	Typ.	Max.		
GATE DRIVERS							
	HDRV Rising Time	CL = 1500pF		20	50	nS	
	HDRV Falling Time	CL = 1500pF		15	50	nS	
	LDRV Rising Time	CL = 1500pF		25	50	nS	
	LDRV Falling Time	CL = 1500pF		25	50	nS	
	Dead Band Time		50	150	250	nS	
PROTECTION							
V _{FBUV}	FB Under-Voltage Threshold	V _{FB} Falling	APW7037	0.4	0.6	0.8	V
			APW7037A	0.3	0.4	0.5	
			APW7037B	0.3	0.4	0.5	
V _{SD}	Shutdown Threshold Voltage	Pull the voltage of SS pin		0.5		V	
I _{SS}	Soft-Start Current	SS=0	10	20	30	μA	

Functional Pin Description

FB (Pin 1)

Connect this pin to the output (V_{OUT}) of the PWM converter via an external resistor divider to provide a voltage feedback path for the converter. The output voltage set by the resistor divider is determined using the following formula :

$$V_{OUT} = V_{REF} \times \left(1 + \frac{R_{OUT}}{R_{GND}}\right)$$

where R_{OUT} is the resistor connected from V_{OUT} to FB, and R_{GND} is the resistor connected from FB to ground. The voltage at this pin is also monitored for Under-Voltage protection.

VCC (Pin 2)

Connect this pin to input voltage from 5V to 20V. This pin provides the bias for the control circuitry and the low-side power MOSFET driver (LDRV). The voltage at this pin is monitored for Power-On Reset (POR) purpose.

LDRV (Pin 3)

Connect this pin to the gate of the low-side power MOSFET. This pin provides the gate drive for the MOSFET.

GND (Pin 4)

Signal and power ground for the IC. All voltage levels

are measured with respect to this pin.

HDRV (Pin 5)

Connect this pin to the gate of the high-side power MOSFET. This pin provides the gate drive for the MOSFET.

VC (Pin 6)

This pin provides bias voltage to the high-side MOSFET driver. A bootstrap circuit may be used to pump a boot voltage for enforcing the driving capability of the gate driver and improving the performance of the MOSFET.

COMP (Pin 7)

This pin is the output of the error amplifier. Add an external resistor-capacitor network to provide a loop compensation for the PWM converter.

SS (Pin 8)

Connect a capacitor from this pin to ground. This capacitor, along with an internal 20μA current source, sets the soft-start interval of the PWM converter and prevents the outputs from overshoot as well as limits the input current. Pull this pin below 0.5V can shut-down the converter.

Typical Applications

1. Dual supply voltage(5V and 12V) application

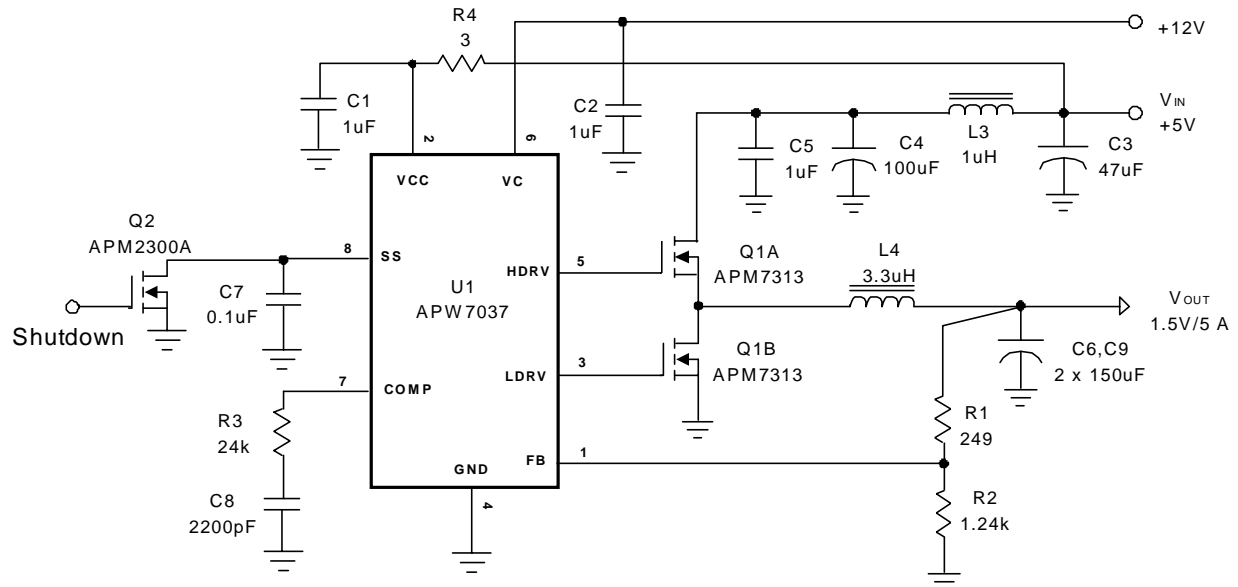

2. Single supply voltage(5V) application

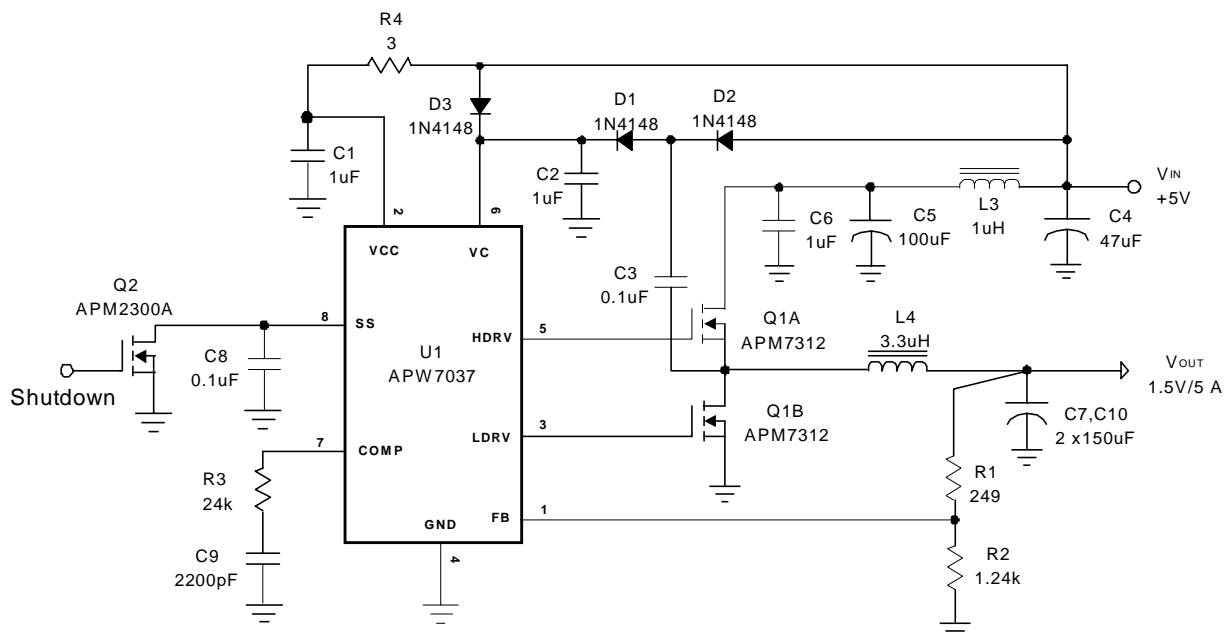

Typical Applications (Cont.)

3. LCD Monitor Application Circuit

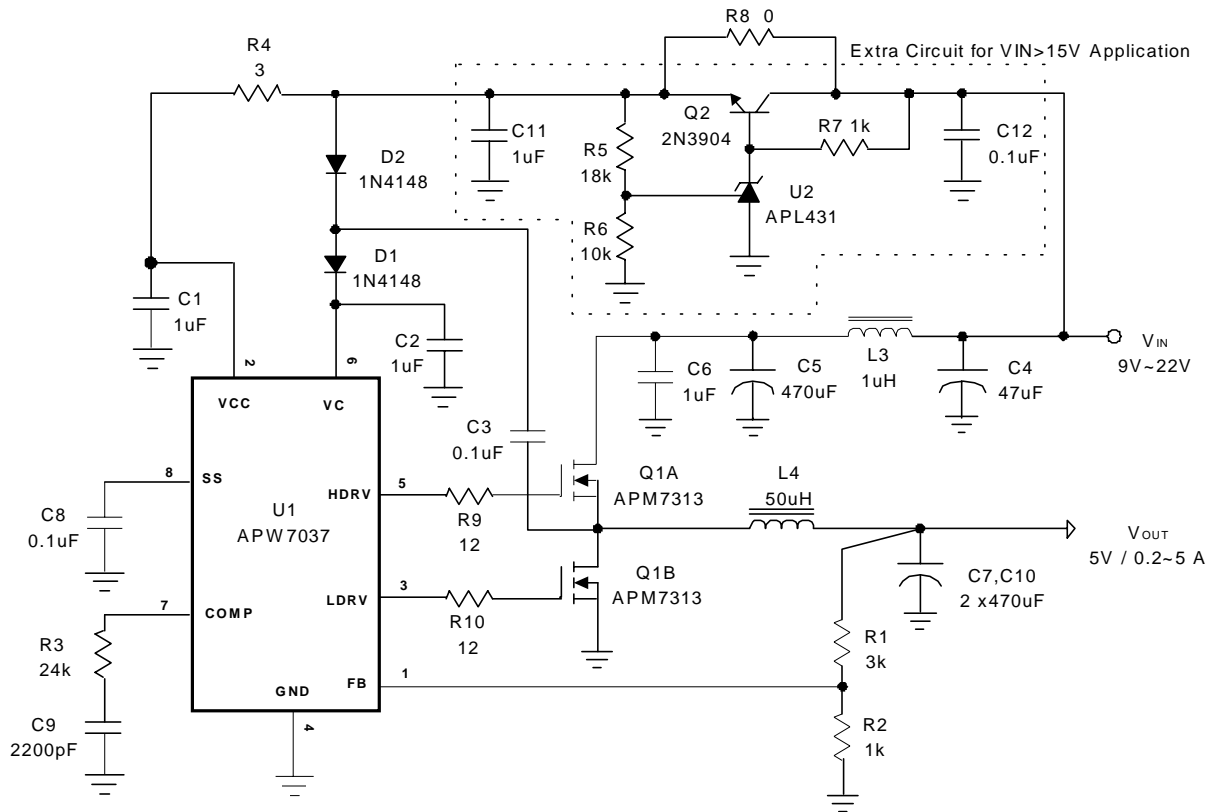

Package Information

SOP-8 pin (Reference JEDEC Registration MS-012)

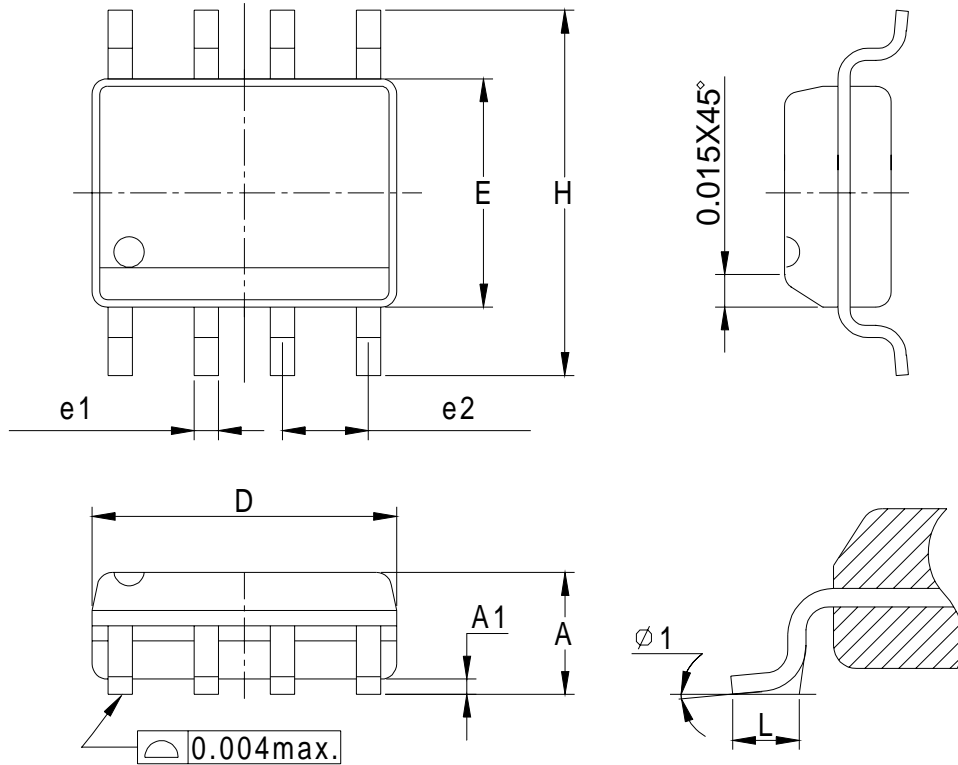

Dim	Millimeters		Inches	
	Min.	Max.	Min.	Max.
A	1.35	1.75	0.053	0.069
A1	0.10	0.25	0.004	0.010
D	4.80	5.00	0.189	0.197
E	3.80	4.00	0.150	0.157
H	5.80	6.20	0.228	0.244
L	0.40	1.27	0.016	0.050
e1	0.33	0.51	0.013	0.020
e2	1.27BSC		0.50BSC	
φ 1	8°		8°	

Package Information

TSSOP-8

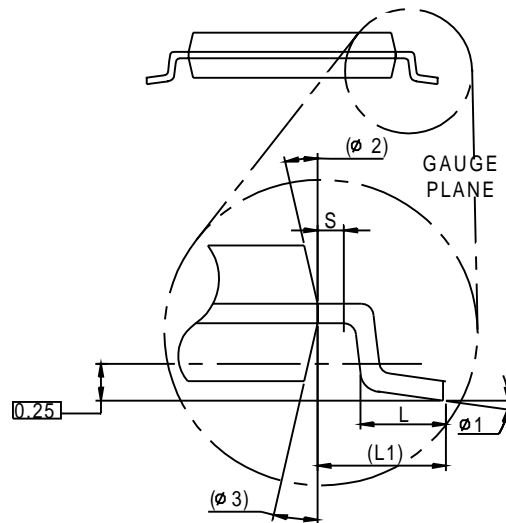
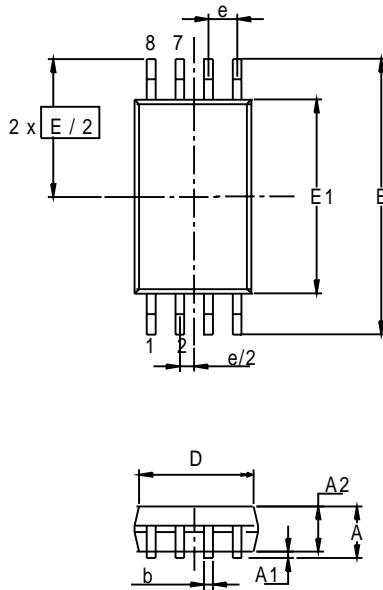

Dim	Millimeters		Inches	
	Min.	Max.	Min.	Max.
A		1.2		0.047
A1	0.00	0.15	0.000	0.006
A2	0.80	1.05	0.031	0.041
b	0.19	0.30	0.007	0.012
D	2.9	3.1	0.114	0.122
e	0.65 BSC		0.026 BSC	
E	6.40 BSC		0.252 BSC	
E1	4.30	4.50	0.169	0.177
L	0.45	0.75	0.018	0.030
L1	1.0 REF		0.039REF	
R	0.09		0.004	
R1	0.09		0.004	
S	0.2		0.008	
phi 1	0°	8°	0°	8°
phi 2	12° REF		12° REF	
phi 3	12° REF		12° REF	

Physical Specifications

Terminal Material	Solder-Plated Copper (Solder Material : 90/10 or 63/37 SnPb), 100%Sn
Lead Solderability	Meets EIA Specification RSI86-91, ANSI/J-STD-002 Category 3.

Reflow Condition (IR/Convection or VPR Reflow)

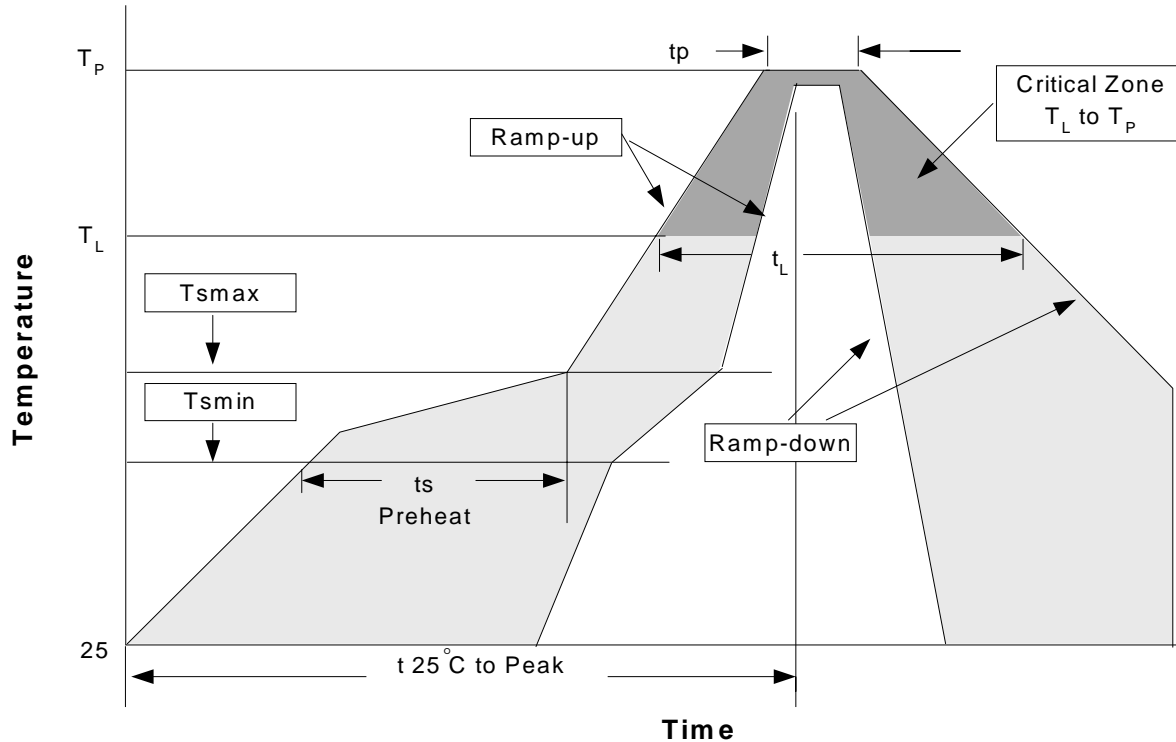

Classification Reflow Profiles

Profile Feature	Sn-Pb Eutectic Assembly		Pb-Free Assembly	
	Large Body	Small Body	Large Body	Small Body
Average ramp-up rate (T _L to T _P)	3°C/second max.		3°C/second max.	
Preheat				
- Temperature Min (T _{smin})	100°C		150°C	
- Temperature Mix (T _{smax})	150°C		200°C	
- Time (min to max)(t _s)	60-120 seconds		60-180 seconds	
T _{smax} to T _L				
- Ramp-up Rate			3°C/second max	
T _{smax} to T _L				
- Temperature(T _L)	183°C		217°C	
- Time (t _L)	60-150 seconds		60-150 seconds	
Peak Temperature(T _p)	225 +0/-5°C	240 +0/-5°C	245 +0/-5°C	250 +0/-5°C
Time within 5°C of actual Peak Temperature(t _p)	10-30 seconds	10-30 seconds	10-30 seconds	20-40 seconds
Ramp-down Rate	6°C/second max.		6°C/second max.	
Time 25°C to Peak Temperature	6 minutes max.		8 minutes max.	

Note: All temperatures refer to topside of the package. Measured on the body surface.

Reliability test program

Test item	Method	Description
SOLDERABILITY	MIL-STD-883D-2003	245°C , 5 SEC
HOLT	MIL-STD-883D-1005.7	1000 Hrs Bias @ 125 °C
PCT	JESD-22-B, A102	168 Hrs, 100 % RH , 121°C
TST	MIL-STD-883D-1011.9	-65°C ~ 150°C, 200 Cycles
ESD	MIL-STD-883D-3015.7	VHBM > 2KV, VMM > 200V
Latch-Up	JESD 78	10ms , I _{tr} > 100mA

Carrier Tape & Reel Dimensions

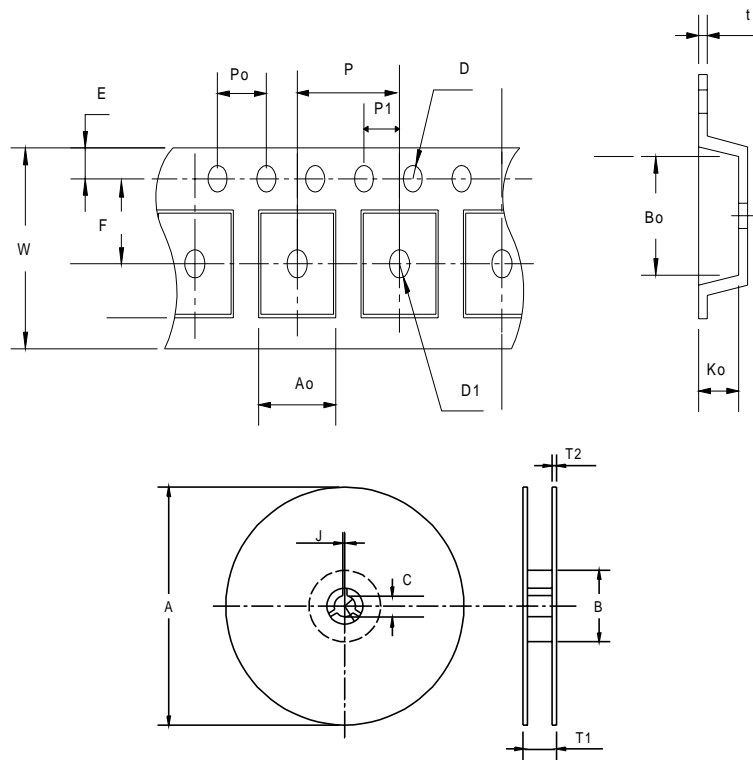

Application	A	B	C	J	T1	T2	W	P	E
SOP-8	330±1	62 ± 1.5	12.75 +0.15	2 + 0.5	12.4 +0.2	2± 0.2	12 + 0.3 - 0.1	8± 0.1	1.75± 0.1
	F	D	D1	Po	P1	Ao	Bo	Ko	t
	5.5 ± 0.1	1.55 ±0.1	1.55+0.25	4.0 ± 0.1	2.0 ± 0.1	6.4 ± 0.1	5.2± 0.1	2.1± 0.1	0.3±0.013
Application	A	B	C	J	T1	T2	W	P	E
TSSOP-8	330 ± 1	62 +1.5	12.75+ 0.15	2 + 0.5	12.4 ± 0.2	2 ± 0.2	12± 0.3	8± 0.1	1.75±0.1
	F	D	D1	Po	P1	Ao	Bo	Ko	t
	5.5 ± 0.1	1.5 + 0.1	1.5 + 0.1	4.0 ± 0.1	2.0 ± 0.1	7.0 ± 0.1	3.6 ± 0.3	1.6 ± 0.1	0.3±0.013

(mm)

Cover Tape Dimensions

Application	Carrier Width	Cover Tape Width	Devices Per Reel
SOP- 8	12	9.3	2500
TSSOP- 8	12	9.3	2500

Customer Service**Anpec Electronics Corp.**

Head Office :

5F, No. 2 Li-Hsin Road, SBIP,

Hsin-Chu, Taiwan, R.O.C.

Tel : 886-3-5642000

Fax : 886-3-5642050

Taipei Branch :

7F, No. 137, Lane 235, Pac Chiao Rd.,

Hsin Tien City, Taipei Hsien, Taiwan, R. O. C.

Tel : 886-2-89191368

Fax : 886-2-89191369