

#### Features

- DC - 6.0 GHz
- 5 Watts
- BeO Ceramic
- Non-Nichrome Resistive Element
- Low VSWR
- 100% Tested

#### General Specifications

<b>Resistive Element:</b>	Thick film
<b>Substrate:</b>	Beryllium oxide ceramic
<b>Terminals:</b>	Thick film silver

#### Electrical Specifications

<b>Resistance Value:</b>	50 ohms, $\pm 2\%$
<b>Frequency Range:</b>	DC - 6.0 GHz
<b>Power:</b>	5 Watts
<b>V.S.W.R.:</b>	1.25:1

**Notes:** Tolerance is  $\pm .010$ , unless otherwise specified. Operating temperature is  $-55^{\circ}\text{C}$  to  $+150^{\circ}\text{C}$  (see chart). Designed to meet or exceed applicable portions of MIL-E-5400. All dimensions are in inches.

**Specifications subject to change without notice.**

#### Outline Drawing

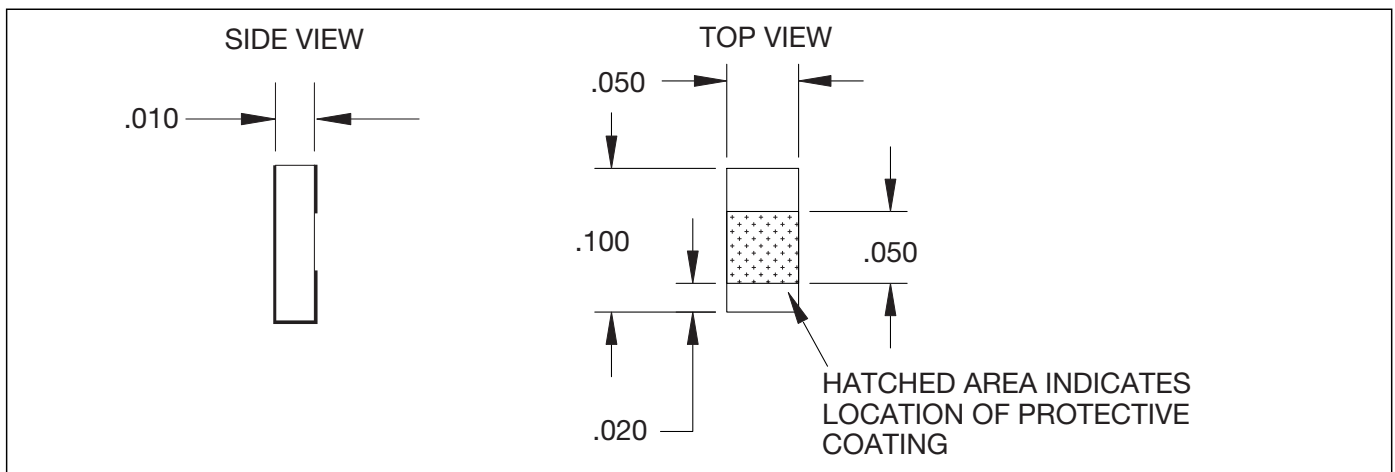

VER. 12/5/01

# Model RFP-050100-1X50-2



**RF Power**

## Typical Performance

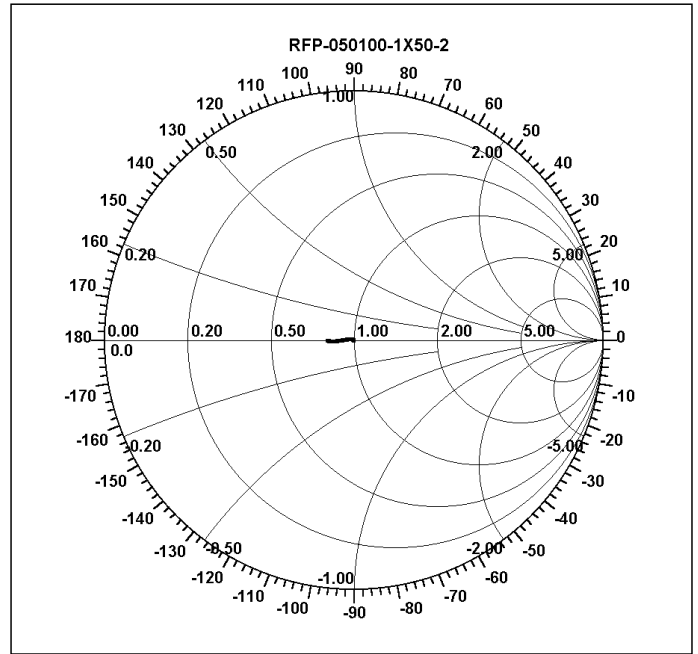
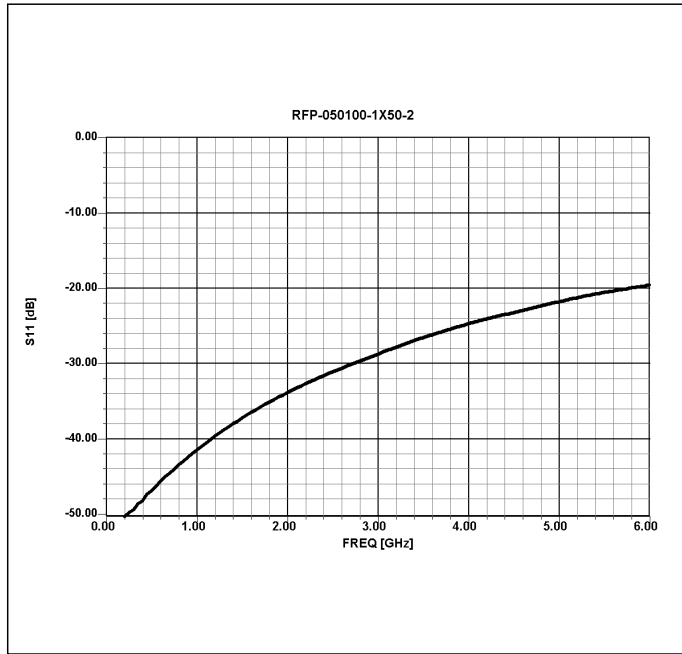

## Power Derating

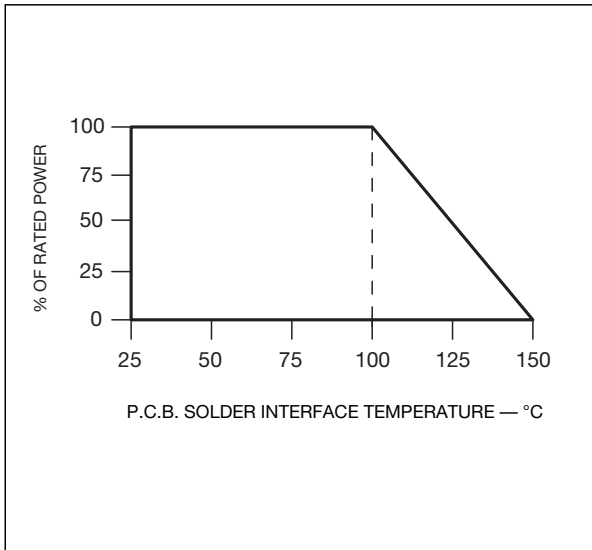

## Suggested Mounting Procedures

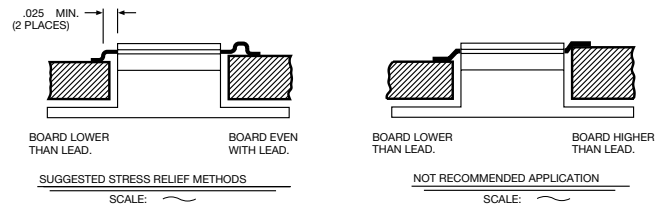

1. Make sure that the devices are mounted on flat surfaces (.001" under the device) to optimize the heat transfer.
2. Position device on mounting surface and solder in place using an indalloy type or a 60/40 type solder.
3. Solder leads in place using a 60/40 type solder with a controlled temperature iron (700°F).