

### Features

- Established Skyworks' Limiter Diode Process
- High Power, Mid-range and Clean-up Designs
- Low Insertion Loss (0.1 dB at 10 GHz)
- Power Handling to 66 dBm
- Tight Control of Basewidth
- Mesa and Planar Chip Designs

### Description

Skyworks' CLA series of silicon limiter diode chips provides passive receiver protection over a wide range of frequencies from 100 MHz to beyond 30 GHz. These devices utilize Skyworks' well established silicon technology for high resistivity and tightly controlled thin base width PIN limiter diodes. Limiter circuits employing these devices will perform with strong limiting action and low loss.

The CLA series consists of eight individual chip designs of different intrinsic region basewidths and capacitances designed to accommodate multi-stage limiter applications. The mesa constructed, thin basewidth, low capacitance CLA4601-000, CLA4602-000, CLA4604-000 and CLA4605-000 are designed for low level and clean-up applications. The CLA4603-000, CLA4606-000 through CLA4608-000 are planar designs designated for high power and mid-range applications.

### Absolute Maximum Ratings

Characteristic	Value
Power Dissipation	$P_{diss} = \frac{175 - T_{amb}}{\theta} \text{ W}$
For CW Signals	$\theta = \theta_{ave}$
For Pulsed Signals	$\theta = DF \times \theta_{ave} + \theta_{pulse}$ ( $\theta_p$ @ 1 $\mu\text{S}$ x Normalized $\theta_p$ from Figure 2)
Operating Temperature	-65°C to +175°C
Storage Temperature	-65°C to +200°C

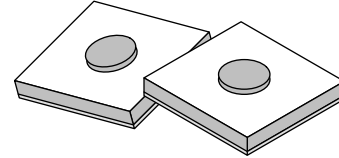

### Outline Drawings

#### 149-801

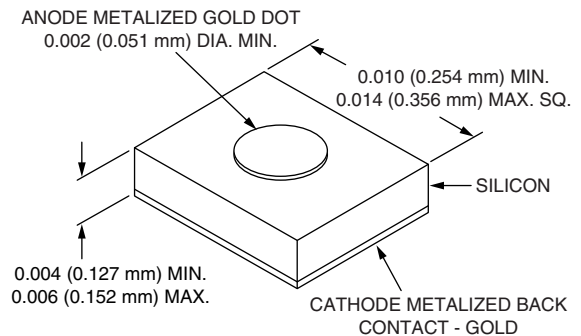

#### 150 Series

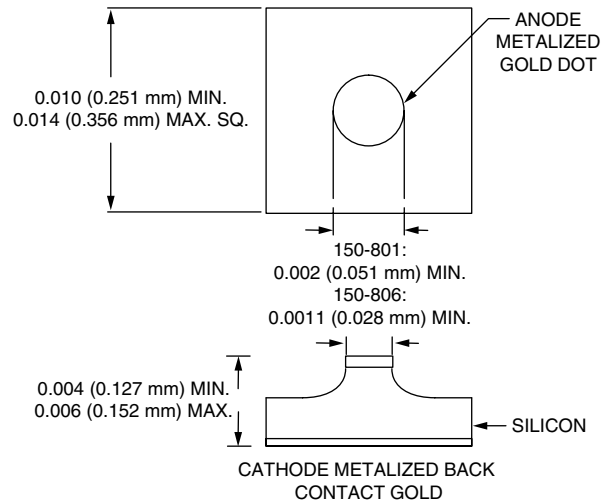

### Electrical Specifications at 25°C

Part Number	Breakdown Voltage (V)	Basewidth (μm)	C <sub>J</sub> @ 0 V (pF)	R <sub>S</sub> @ 10 mA (Ω)	T <sub>L</sub> @ 10 mA (nS)	Thermal Impedance (θ)		Top Contact Diam. (mils/mm)	Outline Drawing
						Average (°C/W)	1 μS Pulse (°C/W)		
	Min. – Max.	Nominal	Max.	Max.	Typ.	Max.	Typ.	Typ.	
CLA4601-000	15–30	1.0	0.15	2.5	5	120	15	1.2/0.030	150-806
CLA4602-000	15–30	1.0	0.2	2.0	5	80	10	1.5/0.038	150-806
CLA4603-000	20–45	1.5	0.2	2.0	5	100	10	1.5/0.038	149-801
CLA4604-000	30–60	2.0	0.15	2.5	7	100	10	1.5/0.038	150-806
CLA4605-000	30–60	2.0	0.2	2.0	7	70	7.0	2.5/0.064	150-801
CLA4606-000	45–75	2.5	0.2	2.0	10	80	7.0	2.5/0.064	150-801
CLA4607-000	120–180	7.0	0.2	2.0	50	40	1.2	3.0/0.076	149-801
CLA4608-000	120–180	7.0	0.6	1.2	100	15	0.3	5.0/0.127	149-801

1. Capacitance, C<sub>J</sub>, measured at 1 MHz.
2. Resistance, R<sub>S</sub>, measured at 100 MHz.
3. CW thermal resistance for infinite heat sink.
4. Pulse thermal resistance for single 1 μS pulse.

### Typical Performance at 25°C

Part Number	Insertion Loss @ -10 dBm (dB)	Input Power for 1 dB Loss (dBm)	Maximum Pulsed Input Power (dBm)	Output at Max. Pulsed Input (dBm)	Maximum CW Input Power (W)	Recovery Time (nS)
CLA4601-000	0.1	7	47	21	2	5
CLA4602-000	0.1	7	50	24	3	5
CLA4603-000	0.1	10	50	22	2	10
CLA4604-000	0.1	12	47	24	3	10
CLA4605-000	0.1	12	50	27	4	10
CLA4606-000	0.1	15	53	27	3	20
CLA4607-000	0.1	20	60	39	6	50
CLA4608-000	0.2	20	66	44	15	100

1. Insertion loss for CLA4601-000 through CLA4607-000 at 10 GHz; insertion loss for CLA4608-000 at 5 GHz.
2. Limiter power results at 1 GHz for shunt connected single limiter diode and DC return in 50 Ω line.
3. Maximum pulsed power for 1 μS pulse and 0.1% duty factor with chip at 25°C heat sink. Derate linearly to 0 W at 175°C.
4. Maximum CW input power at 25°C heat sink. Derate linearly to 0 W at 175°C.
5. Recovery time to insertion loss from limiting state.

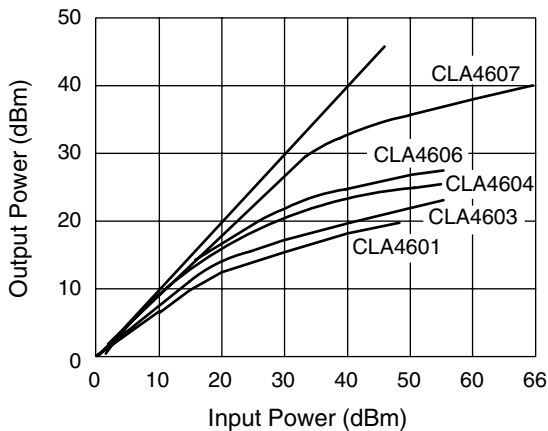

**Figure 1**  
Typical Peak Leakage Power at 1 GHz

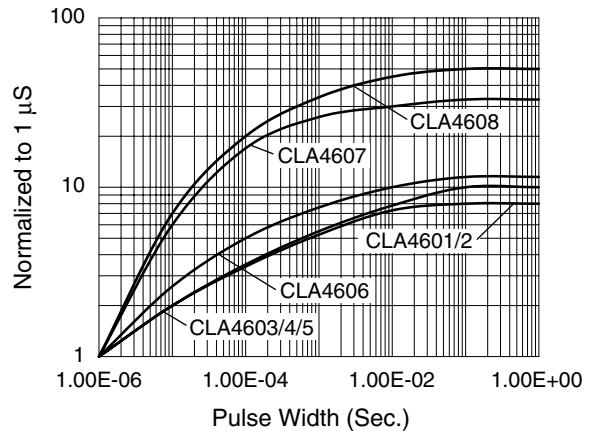

**Figure 2**  
Normalized Pulsed Thermal Impedance