

Optical Reflective Sensors

Technical Data

HBCC-1570
HBCC-1580
HBCC-1590

Features

- **Focused Emitter and Detector in a Single Package**
- **TO-5 Miniature Sealed Package**
- **Photodiode Output**
- **Choice of Resolutions (0.13 mm, 0.178 mm, 0.33 mm)**
- **Two Wavelengths Available; 655 nm, 820 nm (see selection guide)**

Description

The HBCC-15XX series sensors are fully integrated modules designed for applications requiring optical reflective sensing. The modules contain a 655 nm (or 820 nm) LED emitter and a photodiode. A bifurcated aspheric lens is used to image the active areas of the emitter and detector to a single spot 4.27 mm (0.168 in.) in front of the package. The output signal is a current generated by the photodiode.

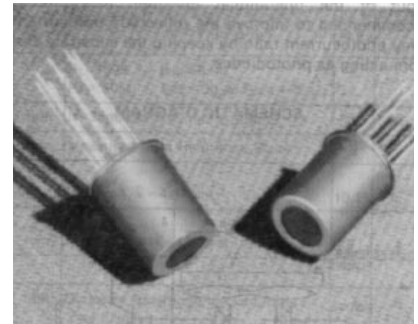

Applications

The HBCC-15XX sensors are intended for use with the Hewlett-Packard HBCC-0500 and HBCC-0600 low current digitizer ICs, or

Selection Guide

Sensor Part Number	HBCC-1570	HBCC-1580	HBCC-1590
LED Resolution	0.33 mm (0.013 in.)	0.185 mm (0.007 in.)	0.13 mm (0.005 in.)
LED Wavelength	655 nm	655 nm	820 nm

Package Dimensions

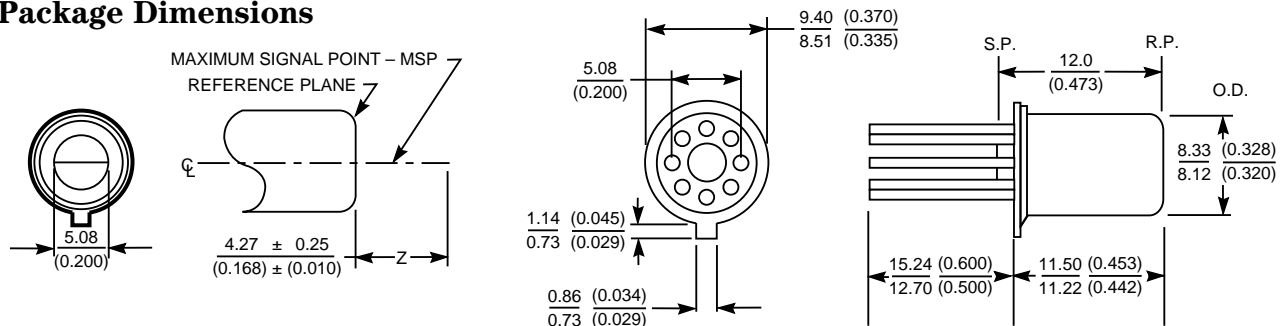

NOTES:

- ALL DIMENSIONS IN MILLIMETERS AND (INCHES).
- ALL UNTOLERANCED DIMENSIONS ARE FOR REFERENCE ONLY.
- THE REFERENCE PLANE (R.P.) IS THE TOP SURFACE OF THE PACKAGE.
- NICKEL CAN AND GOLD PLATED LEADS.

- S.P. = SEATING PLANE.
- THE LEAD DIAMETER IS 0.45 mm (0.018 in.) TYP.
- O.D. = OUTSIDE DIAMETER OF CAN MEASURED IN REGION ABOVE WELD FLANGE TO MIDWAY OF CAN LENGTH.

with suitable PCB assemblies provided by HP for use with these sensors. The HBCC-15XX sensors have been characterized for use only with Hewlett-Packard's digitizer IC technology. Use of these sensors in designs or applications other than those stated is at the customer's risk.

Mechanical Considerations

The HBCC-15XX series are packaged in a high profile 8 pin TO-5 metal can with a glass window. The LED and photodiode are mounted on a header at the base of the package. Positioned above these active elements is a bifurcated aspheric acrylic lens that focuses them to the same point.

The sensor can be rigidly secured by commercially available TO-5 style heat sinks or 8 pin 0.200 inch diameter pin circle sockets. These fixtures provide a stable reference platform for affixing the HBCC-15XX sensors to a circuit board.

In applications requiring contact scanning (such as bar code reading), protective focusing tips are available. Focusing tips are available in either metal or polycarbonate packages using a sapphire ball as the contact surface. The Hewlett-Packard part numbers are HBCS-2999, HBCS-4999, HBCS-A998, and HBCS-A999.

Electrical Operation

The sensor detector is a pn photodiode. The LED cathode is physically and electrically connected to the case-substrate of the sensor.

HBCC-1570, 1580 Optical System

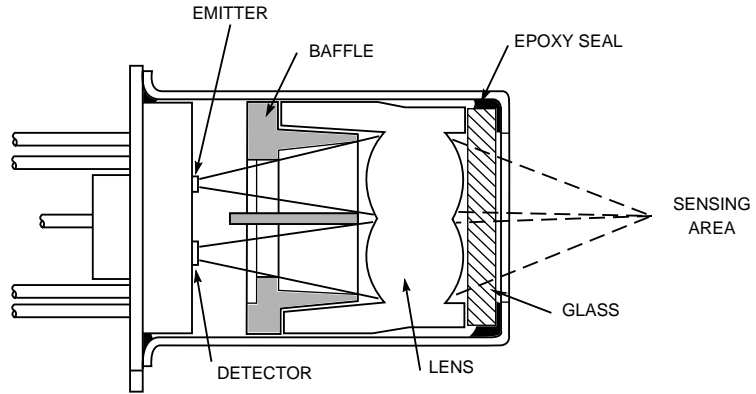

HBCC-1590 Optical System

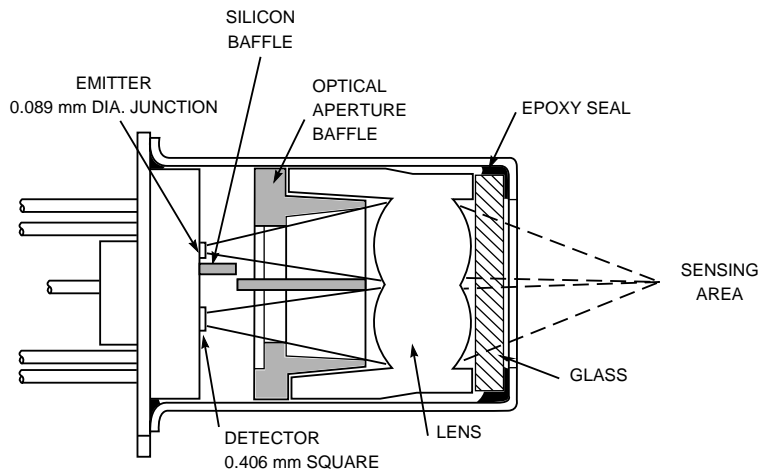

The HBCC-15XX sensors are characterized for use with Hewlett-Packard's low current digitizer ICs. The digitizer IC part numbers are HBCC-0500 and HBCC-0600. Data Sheets including circuit diagrams are available.

Absolute Maximum Ratings

$T_A = 25^\circ\text{C}$ unless specified otherwise (unless specified separately, data applies to all sensors)

Parameter	Symbol	Min.	Max.	Units	Notes
Storage Temperature	T_S	-40	+75	$^\circ\text{C}$	
Operating Temperature	T_A	-20	+75	$^\circ\text{C}$	
Lead Soldering Temperature (1.6 mm from Seating Plane)			260 (for 10 seconds)	$^\circ\text{C}$	1
Average LED Forward Current	I_f				2
Peak LED Forward Current	I_{fp}		125 100 40	mA mA mA	3 (HBCC-1570) 3 (HBCC-1580) 4 (HBCC-1590)
Reverse LED Input Voltage	V_R		5.0 2.5	V V	HBCC-1590 Only
Photodiode Bias	V_d	-0.3	6.0	V	5

Notes:

- CAUTION: The thermal constraints of the acrylic lens will not permit conventional wave soldering procedures. The typical preheat and post-soldering cleaning procedures and dwell times can subject lens to thermal stresses beyond the absolute maximum ratings and can cause it to defocus.
- These sensors are specified for use with the drive conditions provided by the HBCC-0500 and HBCC-0600 Digitizer IC ONLY.
- When used with HBCC-0500 or HBCC-0600 digitizer ICs.
- At all combinations of pulse width and duty cycle.
- Voltage differential between Pin 1 and Pin 8 with Pin 8 taken as reference. Exceeding maximum conditions may cause permanent damage to photodiode or to chip metallization.

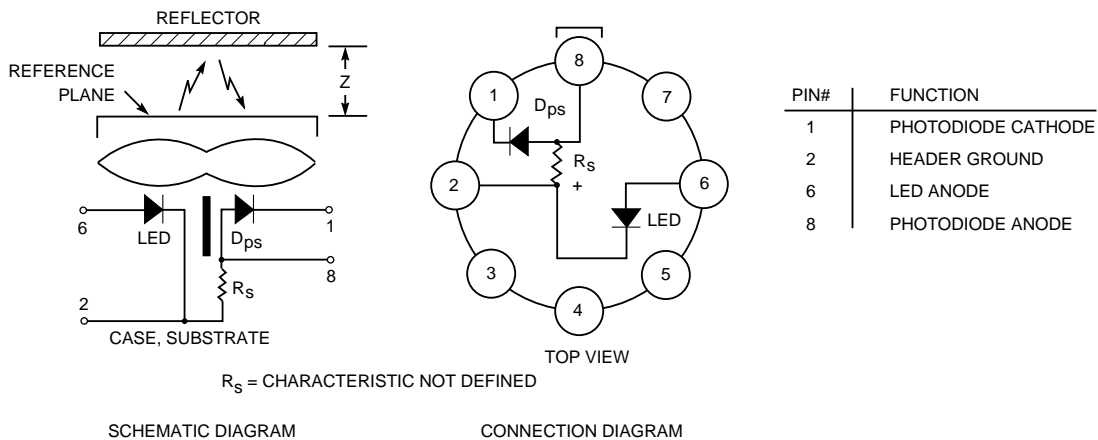

HBCC-1570 and HBCC-1580: Electrical and Optical Characteristics

T_A = 25°C

Parameter	Symbol	Min.	Typ.	Max.	Units	Conditions	Note	Figure
Reflected Photocurrent	I _{pr}	(see Bin Table)			nA	I _f = 70 mA peak	6,7	1,2A, 4A, 4B, 5
Quality Factor	<Q>	0.82	0.95	1.0	-	I _f = 70 mA peak	6,8	
Maximum Signal Point (MSP)	Z	4.11 (0.162)	4.27 (0.168)	4.42 (0.174)	mm (in.)	I _f = 70 mA peak	6,9	1, 4A, 4B
LED Forward Voltage	V _f	1.5	1.75	2.0	V	I _f = 70 mA		3
LED Reverse Breakdown Voltage	BVR	5.0	-	-	V	I _r = 100 μA		
Photodiode Dark Current	I _d	-	60	1000	pA	V _d = 5 V		
Photodiode Capacitance	C _d	-	100 60	- -	pF pF	V _d = 0 V V _d = 1 V		
LED Peak Wavelength	λ	-	650	670	nm	I _f = 35 mA DC		6A
I _{pr} Temperature Coefficient	K _e	-	-0.006	-	1/°C	I _f = 35 mA DC	10	
System Optical Step Response (OSR) HBCC-1570	d	-	0.268 (0.0106)	-	mm (in.)	4.27 mm (Target from sensor)	11	7A
(OSR) HBCC-1580	d	-	0.154 (0.0061)	-	mm (in.)	4.27 mm (Target from sensor)	11	7B

Notes:

6. Measured from a reflector coated with 99% diffuse reflective white paint (Kodak 6080) positioned 4.27 mm (0.168 in.) from the reference plane. Measured physically is the total photocurrent, I_{pt}, which consists of a signal (reflected from target) component, I_{pr}, and a component induced by reflections internal to the sensor (stray), I_{ps}. I_{pt} = I_{pr} + I_{ps}. Specified is the reflected signal component, I_{pr}.
7. See Bin Table
8. <Q> = I_{pr}/I_{pt}
9. Measured from reference plane (R.P.) of sensor.
10. Photocurrent variation with temperature varies with LED output which follows a natural exponential law:

$$I_p(T) = I_p(T_0) \cdot \exp[K_e(T - T_0)]$$
11. OSR is defined as the distance for a 10%-90% "step" response of I_{pr} as the sensor moves over an abrupt black-white edge, or from opaque white to free space (no reflection).

HBCC-1590: Electrical and Optical Characteristics

$T_A = 25^\circ\text{C}$

Parameter	Symbol	Min.	Typ.	Max.	Units	Conditions	Note	Figure
Reflected Photocurrent	I_{pr}	(see Bin Table)			nA	$I_f = 30\text{ mA peak}$	6,7	1,2B, 4C, 5
Quality Factor	$\langle Q \rangle$	0.82	0.95	1.0	-	$I_f = 30\text{ mA peak}$	6,8	
Maximum Signal Point (MSP)	Z	4.01 (0.158)	4.27 (0.168)	4.62 (0.182)	mm (in.)	$I_f = 30\text{ mA peak}$	6,9	1, 4C
LED Forward Voltage	V_f	1.3	1.45	1.8	V	$I_f = 30\text{ mA}$		3
LED Reverse Breakdown Voltage	BVR	2.5	-	-	V	$I_r = 100\text{ }\mu\text{A}$		
Photodiode Dark Current	I_d	-	60	1000	pA	$V_d = 5\text{ V}$		
Photodiode Capacitance	C_d	-	100 60	-	pF pF	$V_d = 0\text{ V}$ $V_d = 1\text{ V}$		
LED Peak Wavelength	λ	805	820	835	nm	$I_f = 35\text{ mA DC}$		6B
I_{pr} Temperature Coefficient	K_e	-	-0.005	-	$1/^\circ\text{C}$	$I_f = 35\text{ mA DC}$	10	
System Optical Step Response (OSR)	d	-	0.140 (0.0055)	-	mm (in.)	4.27 mm (Target from sensor)	11	7C

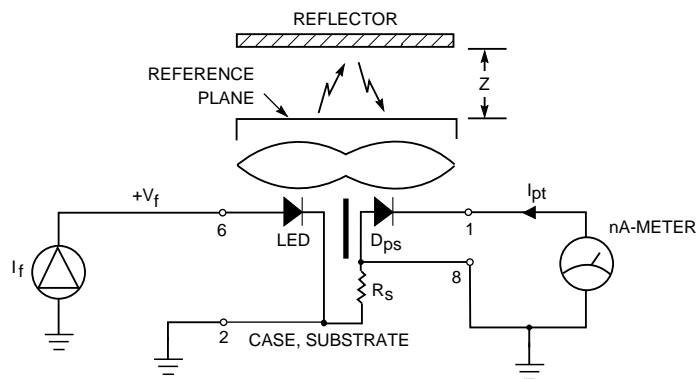

Figure 1. Photocurrent Test Circuit.

Bin Table

Bin#	Ipr Limits (nA)	
	Min.	Max.
1	160	225
2	215	270
3	255	313
4	300	375
5	360	440
6	430	555

Product Marking

The photocurrent binning of the sensor is incorporated as part of the product marking format. The Bin # is represented as the last number (N) on the last line of marking.

HP
HBCC-15XX
XXXXXXXXN

N = bin number

Bin Availability

The entire available distribution of parts, appropriately marked, will be shipped. Requests for individual bin selections cannot be honored.

Binning and Temperature Effects

Test algorithm bins units to the lower bin number if a unit is in the bin overlap region. Such units can cross bin boundaries as temperature changes. (Ambient temperature affects LED efficiency slightly and may cause several percentage changes in Ipr.) Bin numbers are for “reference only” and do not constitute an absolute guarantee. The output of all LEDs degrades with time, depending on drive

conditions and temperature. LED degradation is minimized by the drive conditions generated by both the HBCC-0500 and HBCC-0600, (when used as specified).

Warranty and Service

HP Optical Reflective Sensors are warranted for a period of one year after purchase covering defects in material and workmanship. Hewlett-Packard will repair or, at its option, replace products that prove to be defective in material or workmanship under proper use during the warranty period.

NO OTHER WARRANTIES ARE EXPRESSED OR IMPLIED, INCLUDING BUT NOT LIMITED TO THE IMPLIED WARRANTIES OF MERCHANTABILITY AND FITNESS FOR A PARTICULAR PURPOSE. HEWLETT-PACKARD IS NOT LIABLE FOR CONSEQUENTIAL DAMAGES.

For additional warranty or service information please contact your local Hewlett-Packard sales representative or authorized distributor.

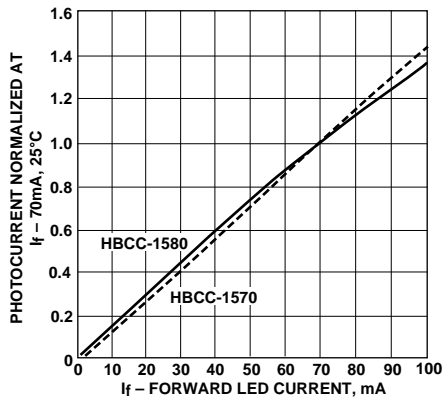

Figure 2A. Typical Reflected Photocurrent.

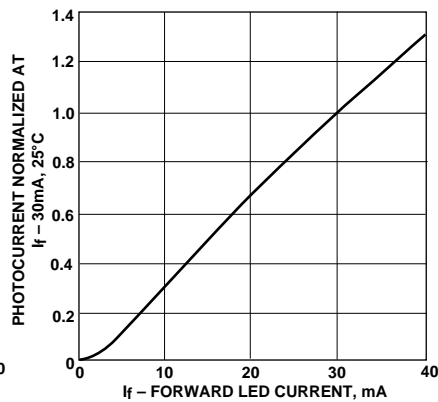

Figure 2B. Typical HBCC-1590 Reflected Photocurrent.

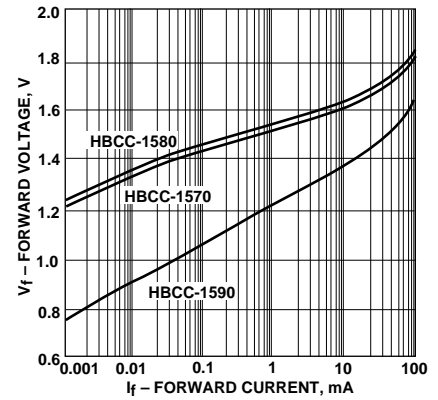

Figure 3. Typical LED Forward Voltage vs. Forward Current.

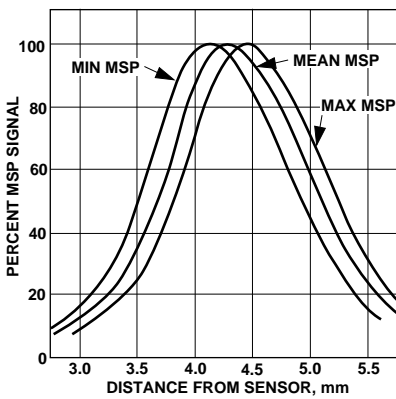

Figure 4A. HBCC-1570 Signal vs. Distance from Sensor.

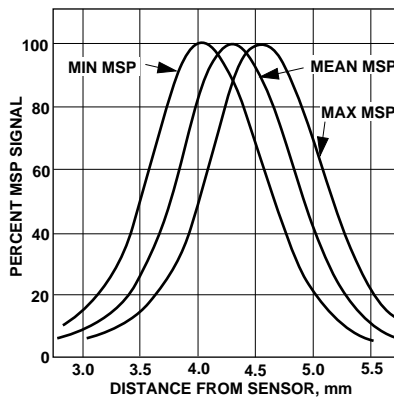

Figure 4B. HBCC-1580 Signal vs. Distance from Sensor.

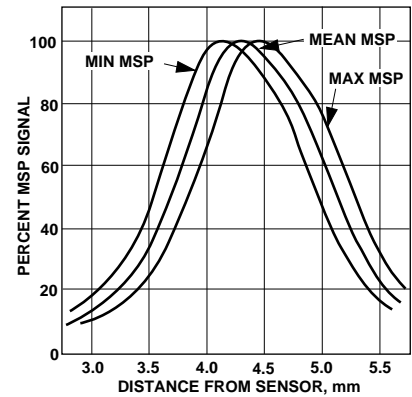

Figure 4C. HBCC-1590 Signal vs. Distance from Sensor.

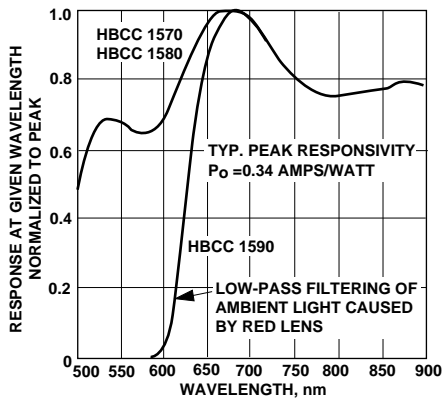

Figure 5. Relative Spectral Response of Sensors.

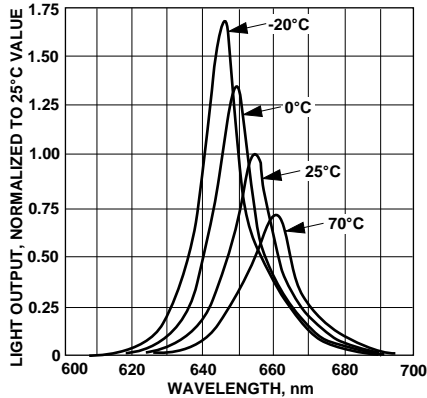

Figure 6A. Typical Spectral Distribution of 655 nm LED.

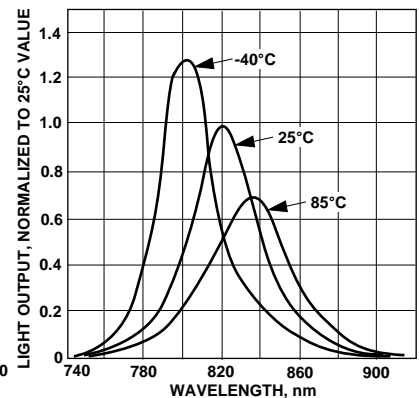

Figure 6B. Typical Spectral Distribution of 820 nm LED.

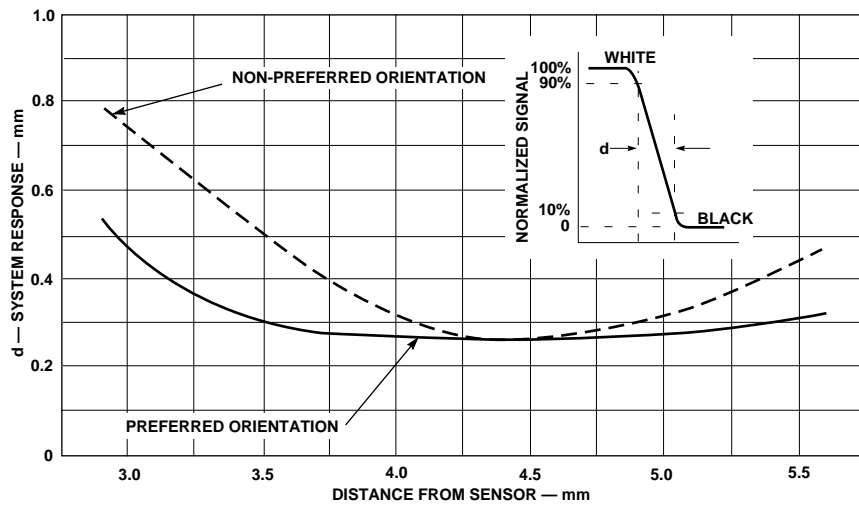
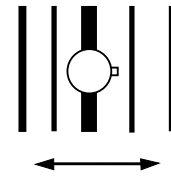

Figure 7A. HBCC-1570, System Optical Step Response Variation with Distance.

Preferred Orientation



At maximum signal point (MSP) when the sensor is in focus, the orientation of the sensor is unimportant. However, as one moves away from MSP (either by distance or angle), the preferred orientation indicated above is recommended to maintain a higher resolution spot size.

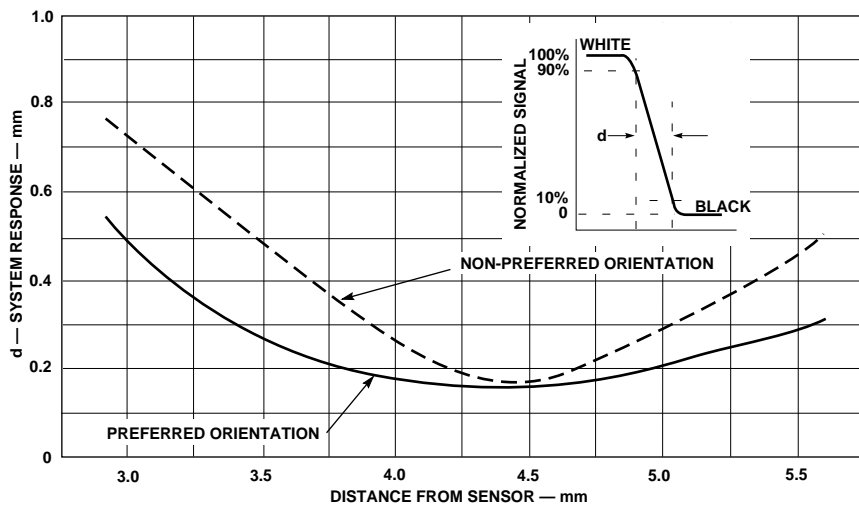

Figure 7B. HBCC-1580, System Optical Step Response Variation with Distance.

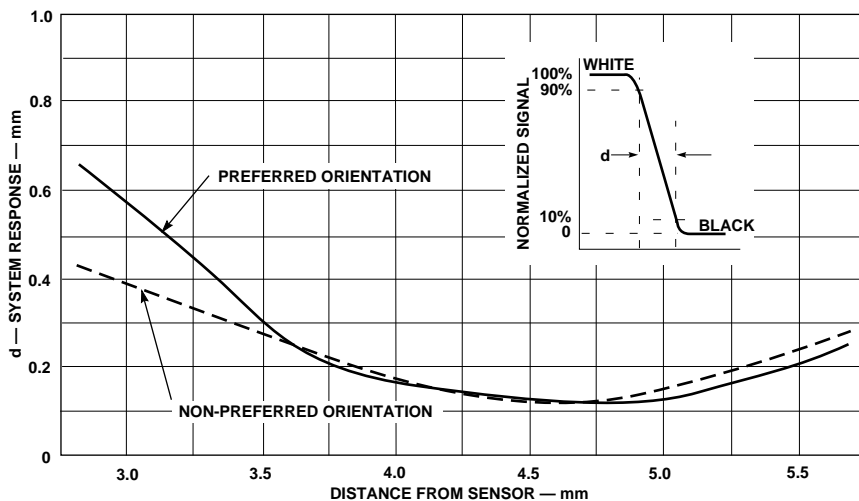

Figure 7C. HBCC-1590, System Optical Step Response Variation with Distance.