

## CA16-Type 2.5 Gbits/s *Translight*<sup>TM</sup> DWDM Transponder with 16-Channel 155 Mbits/s Multiplexer/Demultiplexer



The *Translight* Transponders integrate up to 15 discrete ICs and optical components, including a 2.5 Gbits/s optical transmitter and receiver pair, all in a single, compact package.

### Features

- 2.5 Gbits/s optical transmitter and receiver with 16-channel 155 Mbits/s multiplexer/demultiplexer.
- Available with 1.55  $\mu\text{m}$  cooled DFB laser transmitter and an APD receiver for long-reach applications.
  - Offers 45 standard ITU wavelengths with 100 GHz spacing.
  - Each module is capable of two wavelengths under user control.
- Pigtailed, low-profile package.
- Differential LVPECL data interface.
- Operating case temperature range: 0 °C to 65 °C.
- Automatic transmitter optical power control.
- Laser bias monitor output.
- Transmitter laser disable input.
- Line loopback and diagnostic loopback capability.

- Multiple alarms:
  - Loss of signal.
  - Loss of reference clock.
  - Loss of framing.
  - Laser degrade alarm.

### Applications

- Telecommunications
  - Inter- and intraoffice SONET/SDH
  - Subscriber loop
  - Metropolitan area networks
- High-speed data communications

### Description

The CA16-type transponder performs the parallel-to-serial-to-optical transport and optical transport-to-serial-to-parallel function of the section and photonic layers of the SONET/SDH protocol. The CA16 transmitter section performs the bit serialization and optical transmission of SONET/SDH OC-48/STM-16 data that has been formatted into standard SONET/SDH compliant 16-bit parallel format. The CA16 receiver performs the optical-to-electrical conversion function and is then able to detect frame and byte boundaries and demultiplex the serial data into 16-bit parallel OC-48/STM-16 format.

The CA16 transponder does not perform byte-level multiplexing or interleaving.

## Table of Contents

<b>Contents</b>	<b>Page</b>	<b>Tables</b>	<b>Page</b>
Features .....	1	Table 1. CA16-Type Transponder Pinout .....	6
Applications .....	1	Table 2. CA16-Type Transponder Input Pin Descriptions .....	10
Description .....	1	Table 3. CA16-Type Transponder Output Pin Descriptions .....	11
Absolute Maximum Ratings .....	3	Table 4. OC-48/STM-16 Transmitter Optical Characteristics .....	15
Block Diagram.....	4	Table 5. OC-48/STM-16 Receiver Optical Characteristics .....	15
Pin Information .....	5	Table 6. Power Supply Characteristics .....	16
Pin Descriptions .....	6	Table 7. Transmitter Electrical I/O Characteristics... ..	16
Functional Description .....	12	Table 8. Receiver Electrical I/O Characteristics .....	17
Receiver .....	12	Table 9. Transmitter ac Timing Characteristics .....	24
Transmitter .....	12	Table 10. Receiver ac Timing Characteristics .....	24
Loopback Modes .....	13	Table 11. Ordering Information .....	29
Transponder Interfacing .....	13	Table 12. Related Product Information .....	29
Optical Characteristics .....	15		
Electrical Characteristics .....	16	<b>Figures</b>	<b>Page</b>
Timing Characteristics .....	18	Figure 1. CA16-Type Transponder Block Diagram....	4
Transmitter Data Input Timing .....	18	Figure 2. CA16-Type Transponder Pinout .....	5
Input Timing Mode 1 .....	19	Figure 3. Transponder Interfacing.....	13
Input Timing Mode 2 .....	20	Figure 4. Interfacing to the TXREFCLK Input .....	14
Forward Clocking .....	21	Figure 5. Block Diagram Timing Mode 1.....	19
PCLK-to PICLK Timing .....	22	Figure 6. Block Diagram Timing Mode 2.....	20
PHERR/PHINIT .....	23	Figure 7. Forward Clocking of the CA16 Transponder .....	21
Receiver Framing .....	25	Figure 8. PCLK-to PICLK Timing.....	22
Wavelength Selection .....	26	Figure 9. PHERR/PHINIT Timing.....	23
Qualification and Reliability .....	27	Figure 10. ac Input Timing .....	24
Laser Safety Information .....	27	Figure 11. Receiver Output Timing Diagram .....	24
Class I Laser Product.....	27	Figure 12. Frame and Byte Detection .....	25
Electromagnetic Emissions and Immunity .....	27	Figure 13. OOF Timing (FRAMEN = High) .....	25
Outline Diagram .....	28	Figure 14. FRAMEN Timing.....	26
Ordering Information .....	29		
Related Product Information .....	29		

## Description (continued)

Figure 1 shows a simplified block diagram of the CA16-Type transponder. This device is a bidirectional module designed to provide a SONET or SDH compliant electro-optical interface between the SONET/SDH photonic physical layer and the electrical section layer. The module contains a wavelength-tunable (two channels at 100 GHz) 2.5 Gbits/s optical transmitter and a 2.5 Gbits/s optical receiver in the same physical package along with the electronics necessary to multiplex and demultiplex sixteen 155 Mbits/s electrical channels. Clock synthesis, clock recovery, and SONET/SDH frame detection circuits are also included within the module.

In the transmit direction, the transponder module multiplexes sixteen 155 Mbits/s PECL electrical data signals into an optical signal at 2488.32 Mbits/s for launching into optical fiber. An internal 2.488 GHz reference oscillator is phase-locked to an external 155.52 MHz data timing reference.

The optical transmitter is available at any ITU grid wavelength with a 1.55  $\mu\text{m}$  cooled DFB laser for long-reach applications. The optical output signal is SONET and ITU compliant for OC-48/STM-16 applications as shown in Table 4, OC-48/STM-16 Transmitter Optical Characteristics.

In the receive direction, the transponder module receives a 2488.32 Mbits/s optical signal and converts it to an electrical signal, and then extracts a clock signal and demultiplexes the data into sixteen 155 Mbits/s differential LVPECL data signals. When enabled, the module can also detect SONET/SDH frame boundaries. The optical receiver is available with an APD photodetector. The receiver operates over the wavelength range of 1.1  $\mu\text{m}$  to 1.6  $\mu\text{m}$  and is fully compliant to SONET/SDH OC-48/STM-16 physical layer specifications as shown in Table 5, OC-48/STM-16 Receiver Optical Characteristics.

## Absolute Maximum Ratings

Stresses in excess of the absolute maximum ratings can cause permanent damage to the device. These are absolute stress ratings only. Functional operation of the device is not implied at these or any other conditions in excess of those given in the operations sections of the data sheet. Exposure to absolute maximum ratings for extended periods can adversely affect reliability.

Parameter	Symbol	Min	Max	Unit
Operating Case Temperature Range	T <sub>c</sub>	0	75	°C
Storage Case Temperature Range	T <sub>s</sub>	-40	85	°C
Supply Voltage	—	-0.5	5.5	V
Voltage on Any LVPECL Pin	—	0	V <sub>cc</sub>	—
High-speed LVPECL Output Source Current	—	—	50	mA
Static Discharge Voltage <sup>1</sup>	ESD	—	500	V
Relative Humidity (noncondensing)	RH	—	85	%
Receiver Optical Input Power—Biased APD	P <sub>IN</sub>	—	0	dBm
Minimum Fiber Bend Radius	—	1.25 (31.8)	—	in. (mm)

1. Human body model.

Block Diagram

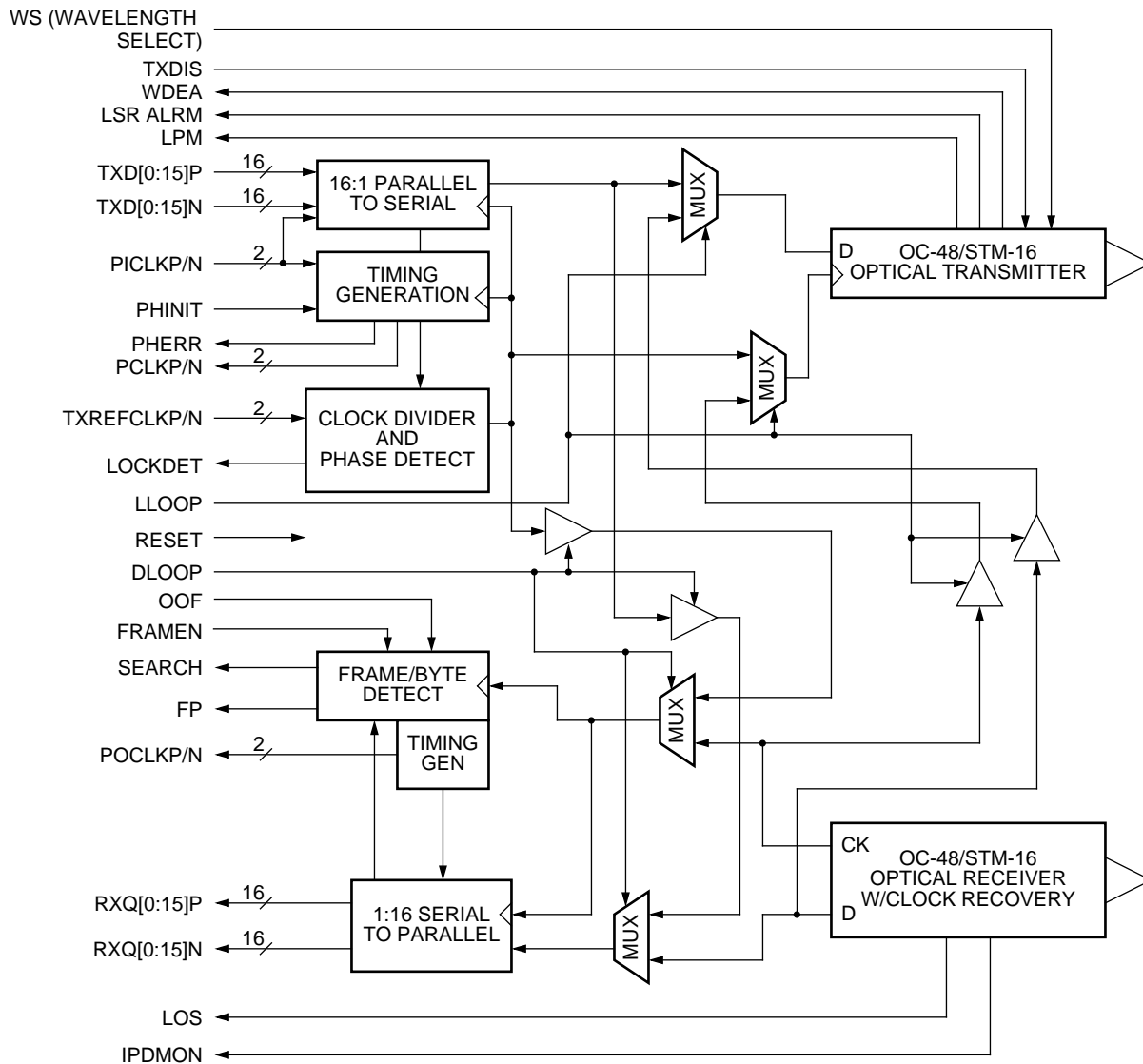
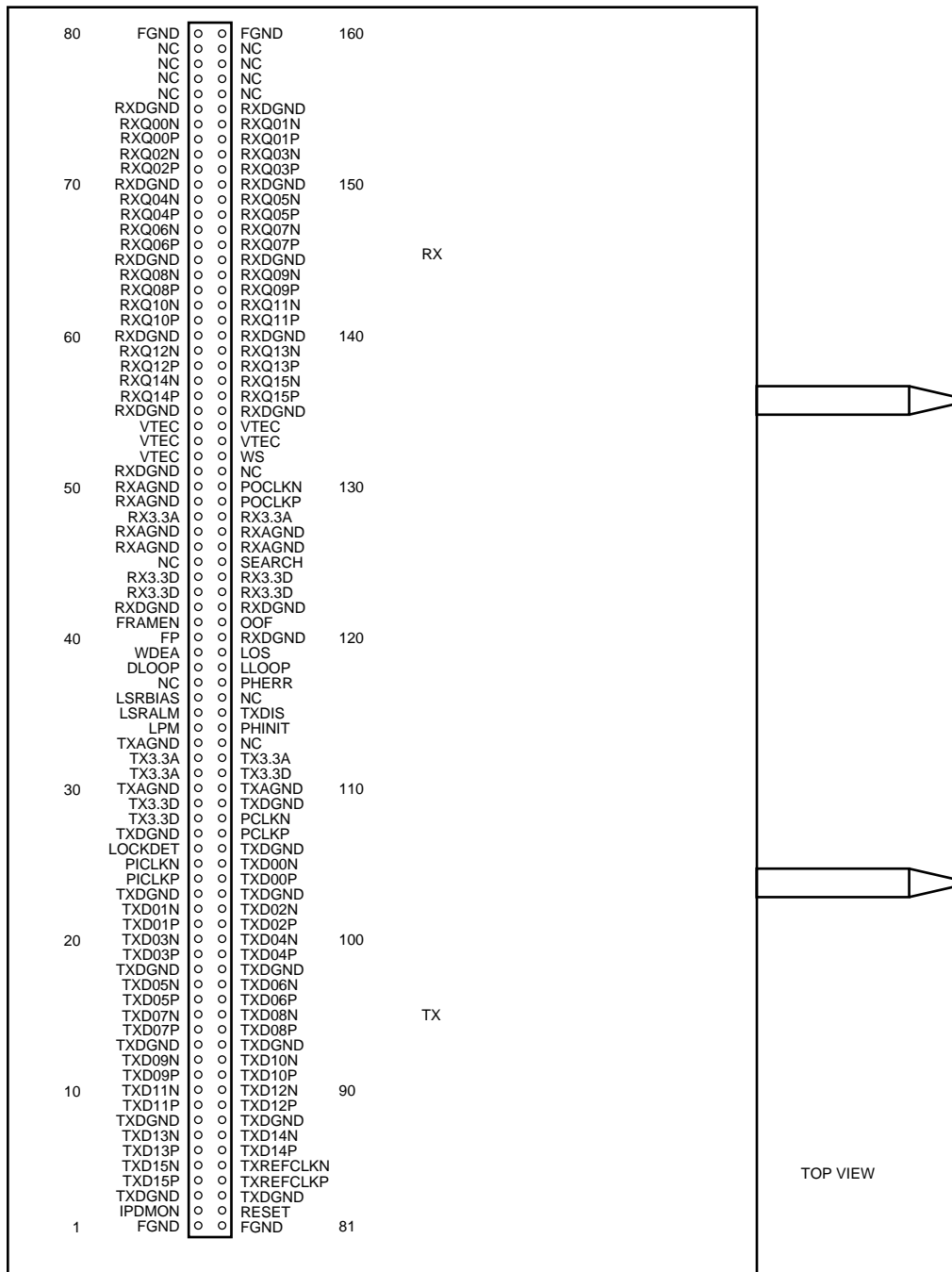

Figure 1. CA16-Type Transponder Block Diagram

1-1011(F).f

Pin Information



TOP VIEW

1-1014(F).d

Figure 2. CA16-Type Transponder Pinout

## Pin Descriptions

Table 1. CA16-Type Transponder Pinout

Pin #	Pin Name	I/O	Logic	Description
01	FGND	I	Supply	Frame Ground <sup>1</sup>
02	IPDMON	O	Analog	Receiver Photodiode Current Monitor
03	TxDGND	I	Supply	Transmitter Digital Ground
04	TxD15P	I	LVPECL	Transmitter 155 Mbits/s MSB Data Input
05	TxD15N	I	LVPECL	Transmitter 155 Mbits/s MSB Data Input
06	TxD13P	I	LVPECL	Transmitter 155 Mbits/s Data Input
07	TxD13N	I	LVPECL	Transmitter 155 Mbits/s Data Input
08	TxDGND	I	Supply	Transmitter Digital Ground
09	TxD11P	I	LVPECL	Transmitter 155 Mbits/s Data Input
10	TxD11N	I	LVPECL	Transmitter 155 Mbits/s Data Input
11	TxD09P	I	LVPECL	Transmitter 155 Mbits/s Data Input
12	TxD09N	I	LVPECL	Transmitter 155 Mbits/s Data Input
13	TxDGND	I	SUPPLY	Transmitter Digital Ground
14	TxD07P	I	LVPECL	Transmitter 155 Mbits/s Data Input
15	TxD07N	I	LVPECL	Transmitter 155 Mbits/s Data Input
16	TxD05P	I	LVPECL	Transmitter 155 Mbits/s Data Input
17	TxD05N	I	LVPECL	Transmitter 155 Mbits/s Data Input
18	TxDGND	I	Supply	Transmitter Digital Ground
19	TxD03P	I	LVPECL	Transmitter 155 Mbits/s Data Input
20	TxD03N	I	LVPECL	Transmitter 155 Mbits/s Data Input
21	TxD01P	I	LVPECL	Transmitter 155 Mbits/s Data Input
22	TxD01N	I	LVPECL	Transmitter 155 Mbits/s Data Input
23	TxDGND	I	Supply	Transmitter Digital Ground
24	PICLkP	I	LVPECL	Byte-Aligned Parallel Input Clock at 155 MHz
25	PICLkN	I	LVPECL	Byte-Aligned Parallel Input Clock at 155 MHz
26	LOCKDET	O	LVTTTL	Lock Detect
27	TxDGND	I	Supply	Transmitter Digital Ground
28	Tx3.3D	I	Supply	Transmitter 3.3 V Digital Supply
29	Tx3.3D	I	Supply	Transmitter 3.3 V Digital Supply
30	TxAGND	I	Supply	Transmitter Analog Ground
31	Tx3.3A	I	Supply	Transmitter 3.3 V Analog Supply
32	Tx3.3A	I	Supply	Transmitter 3.3 V Analog Supply
33	TxAGND	I	Supply	Transmitter Analog Ground
34	LPM	O	Analog	Laser Power Monitor
35	LSRALM	O	5 V CMOS	Laser Degrade Alarm
36	LSRBIAS	O	Analog	Not Implemented on the CA16-Type Transponder
37	NC	—	—	No User Connection Permitted <sup>2</sup>
38	DLOOP	I	LVTTTL	Diagnostic Loopback
39	WDEA	O	5 V CMOS	Wavelength Deviation Error Alarm
40	FP	O	LVPECL	Frame Pulse
41	FRAMEN	I	LVTTTL	Frame Enable

1. Frame ground is connected to the housing and is isolated from all circuit grounds (TxDGND, TxAGND, RxDGND, RxAGND).

2. Pins labeled no connection must remain open circuits; they have internal voltages and must not be connected to Vcc, Ground, or any signal node.

**Pin Descriptions** (continued)

**Table 1. CA16-Type Transponder Pinout** (continued)

Pin #	Pin Name	I/O	Logic	Description
42	RxDGND	I	Supply	Receiver Digital Ground
43	Rx3.3D	I	Supply	Receiver 3.3 V Digital Supply
44	Rx3.3D	I	Supply	Receiver 3.3 V Digital Supply
45	NC	—	—	No User Connection Permitted <sup>2</sup>
46	RxAGND	I	Supply	Receiver Analog Ground
47	RxAGND	I	Supply	Receiver Analog Ground
48	Rx3.3A	I	Supply	Receiver 3.3 V Analog Supply
49	RxAGND	I	Supply	Receiver Analog Ground
50	RxAGND	I	Supply	Receiver Analog Ground
51	RxDGND	I	Supply	Receiver Digital Ground
52	VTEC	I	Supply	TEC Cooler 3 V Analog Supply Voltage
53	VTEC	I	Supply	TEC Cooler 3 V Analog Supply Voltage
54	VTEC	I	Supply	TEC Cooler 3 V Analog Supply Voltage
55	RxDGND	I	Supply	Receiver Digital Ground
56	RxQ14P	O	LVPECL	Receiver 155 Mbits/s Data Output
57	RxQ14N	O	LVPECL	Receiver 155 Mbits/s Data Output
58	RxQ12P	O	LVPECL	Receiver 155 Mbits/s Data Output
59	RxQ12N	O	LVPECL	Receiver 155 Mbits/s Data Output
60	RxDGND	I	Supply	Receiver Digital Ground
61	RxQ10P	O	LVPECL	Receiver 155 Mbits/s Data Output
62	RxQ10N	O	LVPECL	Receiver 155 Mbits/s Data Output
63	RxQ08P	O	LVPECL	Receiver 155 Mbits/s Data Output
64	RxQ08N	O	LVPECL	Receiver 155 Mbits/s Data Output
65	RxDGND	I	SUPPLY	Receiver Digital Ground
66	RxQ06P	O	LVPECL	Receiver 155 Mbits/s Data Output
67	RxQ06N	O	LVPECL	Receiver 155 Mbits/s Data Output
68	RxQ04P	O	LVPECL	Receiver 155 Mbits/s Data Output
69	RxQ04N	O	LVPECL	Receiver 155 Mbits/s Data Output
70	RxDGND	I	Supply	Receiver Digital Ground
71	RxQ02P	O	LVPECL	Receiver 155 Mbits/s Data Output
72	RxQ02N	O	LVPECL	Receiver 155 Mbits/s Data Output
73	RxQ00P	O	LVPECL	Receiver 155 Mbits/s LSB Data Output
74	RxQ00N	O	LVPECL	Receiver 155 Mbits/s LSB Data Output
75	RxDGND	I	Supply	Receiver Digital Ground
76	NC	—	—	No User Connection Permitted <sup>2</sup>
77	NC	—	—	No User Connection Permitted <sup>2</sup>
78	NC	—	—	No User Connection Permitted <sup>2</sup>
79	NC	—	—	No User Connection Permitted <sup>2</sup>
80	FGND	I	Supply	Frame Ground <sup>1</sup>
81	FGND	I	Supply	Frame Ground <sup>1</sup>
82	Reset	I	—	Master Reset

1. Frame ground is connected to the housing and is isolated from all circuit grounds (TxDGND, TxAGND, RxDGND, RxAGND).

2. Pins labeled no connection must remain open circuits; they have internal voltages and must not be connected to Vcc, Ground, or any signal node.

Pin Descriptions (continued)

Table 1. CA16-Type Transponder Pinout (continued)

Pin #	Pin Name	I/O	Logic	Description
83	TxDGND	I	Supply	Transmitter Digital Ground
84	TxREFCLKP	I	LVPECL	Transmitter 155 Mbits/s Reference Clock Input
85	TxREFCLKN	I	LVPECL	Transmitter 155 Mbits/s Reference Clock Input
86	TxD14P	I	LVPECL	Transmitter 155 Mbits/s Data Input
87	TxD14N	I	LVPECL	Transmitter 155 Mbits/s Data Input
88	TxDGND	I	Supply	Transmitter Digital Ground
89	TxD12P	I	LVPECL	Transmitter 155 Mbits/s Data Input
90	TxD12N	I	LVPECL	Transmitter 155 Mbits/s Data Input
91	TxD10P	I	LVPECL	Transmitter 155 Mbits/s Data Input
92	TxD10N	I	LVPECL	Transmitter 155 Mbits/s Data Input
93	TxDGND	I	SUPPLY	Transmitter Digital Ground
94	TxD08P	I	LVPECL	Transmitter 155 Mbits/s Data Input
95	TxD08N	I	LVPECL	Transmitter 155 Mbits/s Data Input
96	TxD06P	I	LVPECL	Transmitter 155 Mbits/s Data Input
97	TxD06N	I	LVPECL	Transmitter 155 Mbits/s Data Input
98	TxDGND	I	Supply	Transmitter Digital Ground
99	TxD04P	I	LVPECL	Transmitter 155 Mbits/s Data Input
100	TxD04N	I	LVPECL	Transmitter 155 Mbits/s Data Input
101	TxD02P	I	LVPECL	Transmitter 155 Mbits/s Data Input
102	TxD02N	I	LVPECL	Transmitter 155 Mbits/s Data Input
103	TxDGND	I	SUPPLY	Transmitter Digital Ground
104	TxD00P	I	LVPECL	Transmitter 155 Mbits/s LSB Data Input
105	TxD00N	I	LVPECL	Transmitter 155 Mbits/s LSB Data Input
106	TxDGND	I	Supply	Transmitter Digital Ground
107	PCLKP	O	LVPECL	Transmitter Parallel Reference Clock Output
108	PCLKN	I	LVPECL	Transmitter Parallel Reference Clock Output
109	TxDGND	I	Supply	Transmitter Digital Ground
110	TxAGND	I	Supply	Transmitter Analog Ground
111	Tx3.3D	I	Supply	Transmitter Digital 3.3 V Supply
112	Tx3.3A	I	Supply	Transmitter Analog 3.3 V Supply
113	NC	—	—	Future Function (I <sup>2</sup> C Clock)
114	PHINIT	I	LVPECL	Phase Initialization
115	TxDIS	I	TTL	Transmitter Disable
116	NC	—	—	Future Function (I <sup>2</sup> C Data)
117	PHERR	O	LVPECL	Phase Error
118	LLOOP	I	LVTTTL	Line Loopback (active-low)
119	LOS	O	LVTTTL	Loss of Signal
120	RxDGND	I	Supply	Receiver Digital Ground
121	OOF	I	LVTTTL	Out of Frame (enable frame detection)
122	RxDGND	I	Supply	Receiver Digital Ground
123	Rx3.3D	I	Supply	Receiver Digital 3.3 V Supply

1. Frame ground is connected to the housing and is isolated from all circuit grounds (TxDGND, TxAGND, RxDGND, RxAGND).
2. Pins labeled no connection must remain open circuits; they have internal voltages and must not be connected to Vcc, Ground, or any signal node.



**Pin Descriptions** (continued)

**Table 1. CA16-Type Transponder Pinout** (continued)

Pin #	Pin Name	I/O	Logic	Description
124	Rx3.3D	I	SUPPLY	Receiver Digital 3.3 V Supply
125	SEARCH	O	LVTTTL	Frame Search Output
126	RxAGND	I	Supply	Receiver Analog Ground
127	RxAGND	I	Supply	Receiver Analog Ground
128	Rx3.3A	I	Supply	Receiver Analog 3.3 V Supply
129	POCLKP	O	LVPECL	Byte-Aligned Parallel Output Clock at 155 MHz
130	POCLKN	O	LVPECL	Byte-Aligned Parallel Output Clock at 155 MHz
131	NC	—	—	No User Connection Permitted <sup>2</sup>
132	WS	I	LVTTTL	Binary Input to Select One of Two Grid Wavelengths
133	VTEC	I	Supply	TEC Cooler 3 V Analog Supply Voltage
134	VTEC	I	Supply	TEC Cooler 3 V Analog Supply Voltage
135	RxDGND	I	Supply	Receiver Digital Ground
136	RxQ15P	O	LVPECL	Receiver MSB 155 Mb/s Data Output
137	RxQ15N	O	LVPECL	Receiver MSB 155 Mb/s Data Output
138	RxQ13P	O	LVPECL	Receiver 155 Mb/s Data Output
139	RxQ13N	O	LVPECL	Receiver 155 Mb/s Data Output
140	RxDGND	I	Supply	Receiver Digital Ground
141	RxQ11P	O	LVPECL	Receiver 155 Mb/s Data Output
142	RxQ11N	O	LVPECL	Receiver 155 Mb/s Data Output
143	RxQ09P	O	LVPECL	Receiver 155 Mb/s Data Output
144	RxQ09N	O	LVPECL	Receiver 155 Mb/s Data Output
145	RxDGND	I	Supply	Receiver Digital Ground
146	RxQ07P	O	LVPECL	Receiver 155 Mb/s Data Output
147	RxQ07N	O	LVPECL	Receiver 155 Mb/s Data Output
148	RxQ05P	O	LVPECL	Receiver 155 Mb/s Data Output
149	RxQ05N	O	LVPECL	Receiver 155 Mb/s Data Output
150	RxDGND	I	Supply	Receiver Digital Ground
151	RxQ03P	O	LVPECL	Receiver 155 Mb/s Data Output
152	RxQ03N	O	LVPECL	Receiver 155 Mb/s Data Output
153	RxQ01P	O	LVPECL	Receiver 155 Mb/s Data Output
154	RxQ01N	O	LVPECL	Receiver 155 Mb/s Data Output
155	RxDGND	I	Supply	Receiver Digital Ground
156	NC	—	—	No User Connection Permitted <sup>2</sup>
157	NC	—	—	No User Connection Permitted <sup>2</sup>
158	NC	—	—	No User Connection Permitted <sup>2</sup>
159	NC	—	—	No User Connection Permitted <sup>2</sup>
160	FGND	I	Supply	Frame Ground <sup>1</sup>

1. Frame ground is connected to the housing and is isolated from all circuit grounds (TxDGND, TxAGND, RxDGND, RxAGND).

2. Pins labeled no connection must remain open circuits; they have internal voltages and must not be connected to Vcc, Ground, or any signal node.

Pin Descriptions (continued)

Table 2. CA16-Type Transponder Input Pin Descriptions

Pin Name	Pin Description
TxD[0:15]P TxD[0:15]N	<b>16-Bit Differential LVPECL Parallel Input Data Bus.</b> TxD15P/N is the most significant bit of the input word and is the first bit serialized. TxD00P/N is the least significant bit of the input word and is the last bit serialized. TxD[0:15]P/N is sampled on the rising edge of PCLK.
PICLK P PICLK N	<b>Differential LVPECL Parallel Input Clock.</b> A 155 MHz nominally 50% duty cycle input clock to which TxD[0:15]P/N is aligned. The rising edge of PCLK transfers the data on the 16 TxD inputs into the holding register of the parallel-to-serial converter.
TxREFCLKP TxREFCLKN	<b>Differential LVPECL Low Jitter 155.520 MHz Input Reference Clock.</b> This input is used as the reference for the internal clock frequency synthesizer, which generates the 2.5 GHz bit rate clock used to shift data out of the parallel-to-serial converter and also for the byte-rate clock, which transfers the 16-bit parallel input data from the input holding register into the parallel-to-serial shift register. Input is internally terminated and biased. See discussion on timing interface, page 18.
TxDIS	<b>Transmitter Disable Input.</b> A logic high on this input pin shuts off the transmitter's laser so that there is no optical output.
WS	<b>Wavelength Select.</b> When this input is a logic 0 or left floating, the output wavelength will be the nominal wavelength (at 25 °C); when it is a logic 1, the wavelength will increase by approximately 0.8 nm (100 GHz frequency decrease).
DLOOP	<b>Diagnostic Loopback Enable (LVTTL).</b> When the DLOOP input is low, the 2.5 Gbits/s serial data stream from the parallel-to-serial converter is looped back internally to the serial-to-parallel converter along with an internally generated bit synchronous serial clock. The received serial data path from the optical receiver is disabled.
LLOOP	<b>Line Loopback Enable (LVTTL).</b> When LLOOP is low, the 2.5 Gbits/s serial data and recovered clock from the optical receiver are looped directly back to the optical transmitter. The multiplexed serial data from the parallel-to-serial converter is ignored.
PHINIT	<b>Phase Initialization (Single-Ended LVPECL).</b> This input is used to align the internal elastic store (FIFO). A rising edge on PHINIT will realign the internal timing (see FIFO discussion, pages 12 and 18).
FRAMEN*	<b>Frame Enable Input (LVTTL).</b> Enables the frame detection circuitry to detect A1, A2 byte alignment and to lock to a word boundary. The CA16 transponder will continually perform frame acquisition as long as FRAMEN is held high. When this input is low, the frame-detection circuitry is disabled. Frame-detection process is initiated by rising edge of out-of-frame pulse.
OOF*	<b>Out of Frame (LVTTL).</b> This input indicator is typically generated by external SONET/SDH overhead monitor circuitry in response to a state in which the frame boundaries of the received SONET/SDH signal are unknown, i.e., after system reset or loss of synchronization. The rising edge of the OOF input initiates the frame detection function if FRAMEN is high. The FP output goes high when the frame boundary is detected in the incoming serial data stream from the optical receiver.
RESET	<b>Master Reset (LVTTL).</b> Reset input for the multiplexer and demultiplexer. A logic low on this input clears all buffers and registers. During RESET, PCLK and PCLK do not toggle.

\* Future versions of the cooled transponder will not support the frame-detect function.

Pin Descriptions (continued)

Table 3. CA16-Type Transponder Output Pin Descriptions

Pin Name	Pin Description
RxQ[0:15]P RxQ[0:15]N	<b>16-Bit Differential LVPECL Parallel Output Data Bus.</b> RxQ[0:15] is the 155 Mbyte/s 16-bit output word. RxQ15P/N is the most significant bit of the received word and is the first bit serialized. RxQ00P/N is the least significant bit of the received word and is the last bit serialized. RxQ[0:15]P/N is updated on the falling edge of POCLK.
POCLKP POCLKN	<b>Differential LVPECL Parallel Output Clock.</b> A 155 MHz nominally 50% duty cycle, byte rate output clock that is aligned to the RxQ[0:15] byte serial output data. RxQ[0:15] and FP are updated on the falling edge of POCLK.
FP*	<b>Frame Pulse (LVPECL).</b> Indicates frame boundaries in the received serial data stream. If framing pattern detection is enabled (FRAMEN high and OOF), FP pulses high for one POCLK cycle when a 32-bit sequence matching the framing pattern is detected in the received serial data. FP is updated on the falling edge of POCLK.
SEARCH*	<b>A1 A2 Frame Search Output (LVTTTL).</b> A high on this output pin indicates that the frame detection circuit is active and is searching for a new A1 A2 byte alignment. This output will be high during the entire A1 A2 frame search. Once a new alignment is found, this signal will remain high for a minimum of one 155 MHz clock period beyond the third A2 byte before it will be set low.
LOS	<b>Loss of Signal (LVTTTL).</b> A low on this output indicates a loss of clock by the clock recovery circuit in the optical receiver.
LSRBIAS	<b>Laser Bias Alarm (Analog).</b> The analog bias alarm is not available on the CA16 transponders.
LSRALM	<b>Laser Degrad Alarm (5 V CMOS).</b> This output goes to a logic 0 when the laser output power degrades 2 dB below the nominal output power.
LPM	<b>Laser Power Monitor (Analog).</b> Provides an indication of the output power level from the transmitter laser. This output is set at 500 mV for the nominal transmitter optical output power. If the optical power decreases by 3 dB, this output will drop to approximately 250 mV, and if the output power should increase by 3 dB, this output will increase to 1000 mV.
PCLKP/N	<b>Parallel Byte Clock (Differential LVPECL).</b> A byte-rate reference clock generated by dividing the internal 2.488 GHz serial bit clock by 16. This output is normally used to synchronize byte-wide transfers from upstream logic into the CA16 transponder. See timing discussion for additional details, page 18.
PHERR	<b>Phase Error Signal (Single-Ended LVPECL).</b> Pulses high during each PCLK cycle for which there is a potential setup/hold timing violation between the internal byte clock and the PCLK timing domain. PHERR is updated on the falling edge of the PCLK outputs.
IPDMON	<b>Receiver Photodiode Current Monitor (Analog).</b> This output provides a current output that is a mirror of the of the photocurrent generated by the optical receiver's photodetector diode (APD or PIN). A 10 kΩ resistor from pin 2 to ground provides a voltage at this output ranging from ~1 mV to ~800 mV, depending on the optical input power.
WDEA	<b>Wavelength Deviation Alarm (5 V TTL).</b> This output changes logic levels whenever the optical transmitter's wavelength deviates from the nominal wavelength by more than ±100 pm.
LOCKDET	<b>Lock Detect (LVTTTL).</b> This output goes low after the transmit side PLL has locked to the clock signal provided at the TxREFCLK input pins. LOCKDET is an asynchronous output.

\* Future versions of the cooled transponder will not support the frame-detect function.

## Functional Description

### Receiver

The optical receiver in the CA16-type transponder has an APD and is optimized for the particular SDH/SONET application segment in which it was designed to operate. The detected serial data output of the optical receiver is connected to a clock and data recovery circuit (CDR), which extracts a 2488.32 MHz clock signal. This recovered serial bit clock signal and a retimed serial data signal are presented to the 16-bit serial-to-parallel converter and to the frame and byte detection logic.

The serial-to-parallel converter consists of three 16-bit registers. The first is a serial-in parallel-out shift register, which performs serial-to-parallel conversion. The second is an internal 16-bit holding register, which transfers data from the serial-to-parallel register on byte boundaries as determined by the frame and byte detection logic. On the falling edge of the free-running POCLK signal, the data in the holding register is transferred to the output holding register where it becomes available as RxQ[0:15].

**Note: Future versions of the cooled transponder will not support the frame-detect function.**

The frame and byte boundary detection circuitry searches the incoming data for three consecutive A1 bytes followed immediately by an A2 byte. Framing pattern detection is enabled and disabled by the FRAMEN input. The frame detection process is started by a rising edge on OOF while FRAMEN is active (FRAMEN = high). It is disabled when a framing pattern is detected. When framing pattern detection is enabled (FRAMEN = high), the framing pattern is used to locate byte and frame boundaries in the incoming serial data stream from the CDR circuits. During this time, the parallel output data bus (RxQ[0:15]) will not contain valid data. The timing generator circuitry takes the located byte boundary and uses it to block the incoming serial data stream into bytes for output on the parallel output data bus (RxQ[0:15]). The frame boundary is reported on the framing pulse (FP) output when any 32-bit pattern matching the framing pattern is detected in the incoming serial data stream. When framing detection is disabled (FRAMEN = low), the byte boundary is fixed at the location found when frame detection was previously enabled.

### Transmitter

The optical transmitter in the CA16-type transponder is optimized for the particular SDH/SONET segment in which it is destined to operate. The transmitter has a cooled DFB laser as the optical element and operates at a nominal 1550 nm (45 standard ITU wavelengths are available for DWDM applications). Under user control, the transmitter can switch to either one of two adjacent ITU wavelengths (100 GHz spacing). The transmitter is driven

by a serial data stream developed in the parallel-to-serial conversion logic and by a 2488.32 MHz serial bit clock signal synthesized from the 155.52 MHz TxREFCLK input.

Note that the clock divider and phase-detect circuitry shown in Figure 1 generates internal reference clocks and timing functions for the transmitter. Therefore, it is important that the TxREFCLK input is generated from a precise and stable source. To prevent internal timing signals from producing jitter in the transmitted serial data that exceeds the SDH/SONET jitter generation requirements of 0.01 UI, it is required that the TxREFCLK input be generated from a crystal oscillator or other source having a frequency accuracy better than 20 ppm. In order to meet the SDH/SONET jitter generation requirement, the reference clock jitter must be guaranteed to be less than 1 ps rms over the 12 kHz to 20 MHz bandwidth. When used in SONET network applications, this input clock must be derived from a source that is synchronized to the primary reference clock.

The timing generation circuitry provides two separate functions. It develops a byte rate clock that is synchronized to the 2488.32 MHz transmit serial clock, and it provides a mechanism for aligning the phase between the incoming byte clock (PICKL) and the clock that loads the parallel data from the input register into the parallel-to-serial shift register.

The PCLK output is a byte rate (155 MHz) version of the serial transmit clock and is intended for use by upstream multiplexing and overhead processing circuits. Using PCLK for upstream circuits will ensure a stable frequency and phase relationship between the parallel data coming into the transmitter and the subsequent parallel-to-serial timing functions. In the parallel-to-serial conversion process, the incoming data is passed from the PICKL byte clock timing domain to the internally generated byte clock timing domain that is phase aligned to the internal serial transmit clock. The timing generator also produces a feedback reference clock to the phase detector. A counter divides the synthesized clock down to the same frequency as the reference clock TxREFCLK.

The parallel-to-serial converter shown in Figure 1 is comprised of an FIFO and a parallel-to-serial register. The FIFO input latches the data from the TxD[0:15]P/N bus on the rising edge of PICKL. The parallel-to-serial register is a loadable shift register that takes parallel input from the FIFO output. An internally generated divide-by-16 clock, which is phase aligned to the transmit serial clock, as described above, activates the parallel data transfer between registers. The serial data is shifted out of the parallel-to-serial register at the transmit serial clock rate.

## Functional Description (continued)

### Loopback Modes

The CA16-type transponder is capable of operating in either of two loopback modes: diagnostic loopback or line loopback.

#### Line Loopback

When LLOOP is pulled low, the received serial data stream and recovered 2488.32 MHz serial clock from the optical receiver are connected directly to the serial data and clock inputs of the optical transmitter. This establishes a receive-to-transmit loopback at the serial line rate.

#### Diagnostic Loopback

When DLOOP is pulled low, a loopback path is established from the transmitter to the receiver. In this mode, the serial data from the parallel-to-serial converter and the transmit serial clock is looped back to the serial-to-parallel converter and the frame and byte detect circuitry, respectively.

## Transponder Interfacing

The TxD[0:15]P/N, TxREFCLKP/N, and PCLKP/N inputs and the RxQ[0:15]P/N, POCLKP/N, and PCLKP/N outputs are high-speed (155 Mbits/s), LVPECL differential data and clock signals. To maintain optimum signal fidelity, these inputs and outputs must be connected to their terminating devices via 50  $\Omega$  controlled-impedance transmission lines. The transmitter inputs (TxD[0:15]P/N, TxREFCLKP/N, and PCLKP/N) must be terminated as close as possible to the CA16 transponder connector with a Thevenin equivalent impedance equal to 50  $\Omega$  terminated to  $V_{cc} - 2$  V. The receiver outputs (RxQ[0:15]P/N, POCLKP/N, and PCLKP/N) must be terminated as close as possible to the device (IC) that these signals interface to with a Thevenin equivalent impedance equal to 50  $\Omega$  terminated to  $V_{cc} - 2$  V.

Figure 3, below, shows one example of the proper terminations. Other methods may be used, provided they meet the requirements stated above.

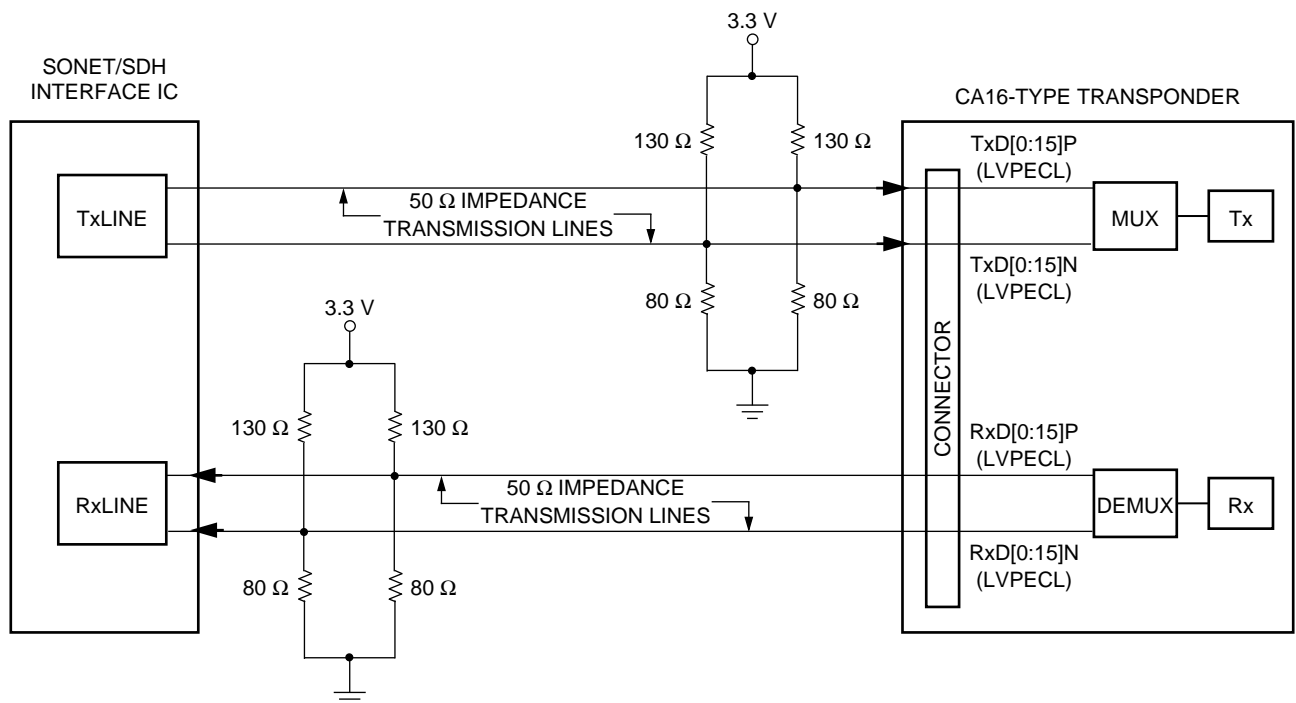

1-1054(F)

Figure 3. Transponder Interfacing

**Functional Description** (continued)

**Transponder Interfacing** (continued)

**TxREFCLKP/N**

The TxREFCLK input is different than the other inputs to the transmitter because it is internally terminated, ac-coupled, and self-biased. Therefore, it must be treated

differently than the TxD and PICLK inputs. Differentially, the input impedance at this input is 100 Ω, but due to the way it is biased internally, when driven single-ended, the impedance appears as 60 Ω. The proper termination scheme for the TxREFCLK input is shown in Figure 4.

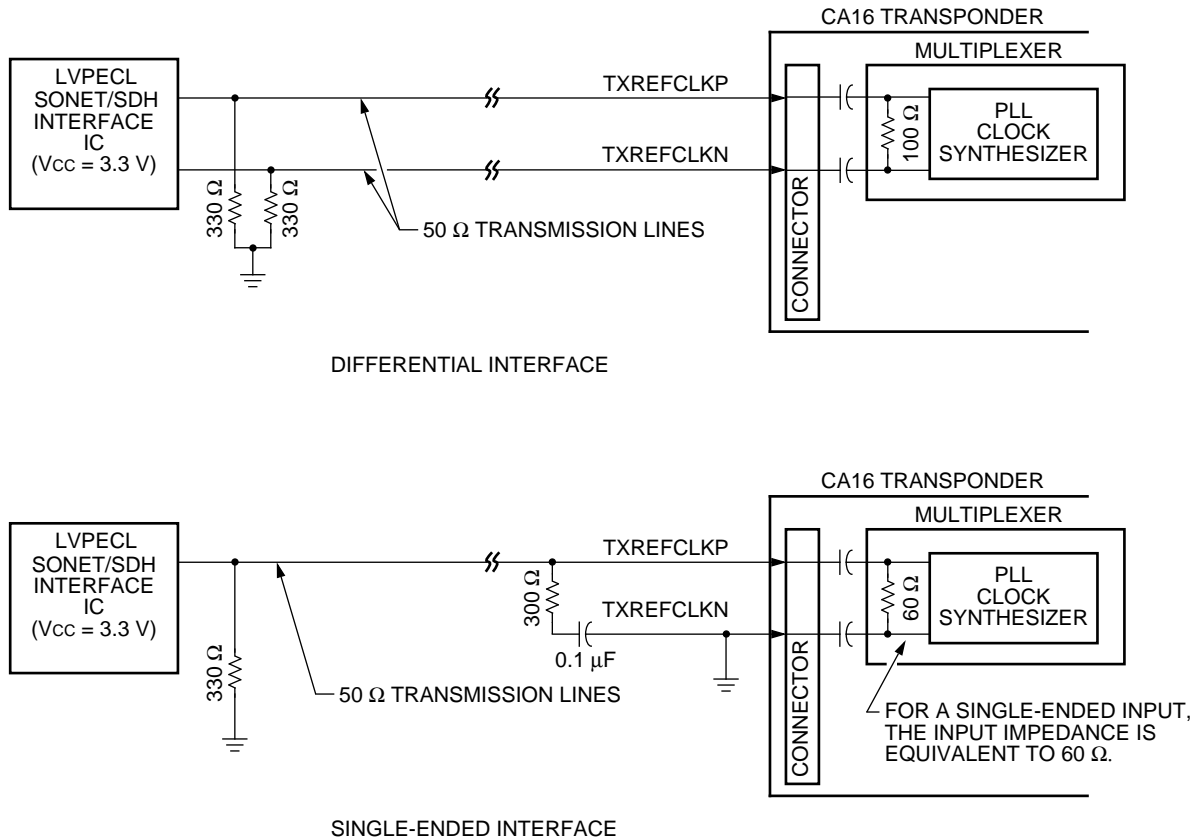

**Figure 4. Interfacing to the TxRefClk Input**

1-1084 (F).c

## Optical Characteristics

Minimum and maximum values specified over operating case temperature range at 50% duty cycle data signal. Typical values are measured at room temperature unless otherwise noted.

**Table 4. OC-48/STM-16 Transmitter Optical Characteristics** (Tc = 0 °C to 65 °C)

Parameter	Symbol	Min	Typ	Max	Unit
Average Output Power: <sup>1</sup> Long Reach (1.55 μm DFB laser)	P <sub>o</sub>	-2	0	3	dBm
Operating Wavelength: Long Reach (1.55 μm DFB laser); All 48 100 GHz ITU Grid Channels Available	λ	1528	—	1563	nm
Variation in Center Wavelength Over Operating Temperature (EOL)	Δλ	-0.06	—	0.06	nm
Spectral Width: Long Reach (DFB laser) <sup>2</sup>	Δλ <sub>20</sub>	—	—	1	nm
Side-mode Suppression Ratio (DFB laser) <sup>3</sup>	SSR	30	—	—	dB
Extinction Ratio <sup>4</sup>	r <sub>e</sub>	8.2	—	—	dB
Optical Rise and Fall Time: CA16A2-Type CA16B2-Type	t <sub>R</sub> , t <sub>F</sub>	— —	— —	140 130	ps ps
Dispersion Penalty: CA16A2-Type CA16B2-Type	DP	— —	— —	2.0 2.0	dB dB
Eye Mask of Optical Output <sup>5, 6</sup>	Compliant with GR-253 and ITU-T G.957				
Jitter Generation	Compliant with GR-253 and ITU-T G.958				

1. Output power definitions and measurements per ITU-T Recommendation G.957.
2. Full spectral width measured 20 dB down from the central wavelength peak under fully modulated conditions.
3. Ratio of the average output power in the dominant longitudinal mode to the power in the most significant side mode under fully modulated conditions.
4. Ratio of logic 1 output power to logic 0 output power under fully modulated conditions.
5. GR-253-CORE, *Synchronous Optical Network (SONET) Transport Systems: Common Generic Criteria*.
6. ITU-T Recommendation G.957, *Optical Interfaces for Equipment and Systems Relating to the Synchronous Digital Hierarchy*.

**Table 5. OC-48/STM-16 Receiver Optical Characteristics** (Tc = 0 °C to 65 °C)

Parameter	Symbol	Min	Typ	Max	Unit
Average Receiver Sensitivity <sup>1</sup> : APD Receiver	PR <sub>MIN</sub>	-29	-34	—	dBm
Maximum Optical Power: APD Receiver (long reach)	PR <sub>MAX</sub>	-8	-6	—	dBm
Link Status Switching Threshold: APD Decreasing Light Input	LSTD	—	TBD	—	dBm
Link Status Response Time	—	3	—	100	μs
Optical Path Penalty	—	—	—	2	dB
Receiver Reflectance	—	—	—	-27	dB
Jitter Tolerance and Jitter Transfer	Compliant with GR-253 and ITU-T G.958				

1. At 1310 nm, 1 x 10<sup>-10</sup> BER, 2<sup>23</sup> – 1 pseudorandom data input.

## Electrical Characteristics

**Table 6. Power Supply Characteristics** ( $T_c = 0\text{ }^\circ\text{C}$  to  $65\text{ }^\circ\text{C}$ )

Parameter	Symbol	Min	Typ	Max	Unit
Supply Voltage	V <sub>CC</sub>	3.13	3.3	3.47	V
dc Power Supply Current Drain	I <sub>CC</sub>	—	2000	—	mA
TEC Voltage	V <sub>TEC</sub>	3.0	3.3	3.5	V
TEC-Only Current Drain	TEC_I <sub>CC</sub>	—	0.6	1200	mA
Power Dissipation	P <sub>DISS</sub>	—	<9	—	W

**Table 7. Transmitter Electrical I/O Characteristics** ( $T_c = 0\text{ }^\circ\text{C}$  to  $65\text{ }^\circ\text{C}$ , V<sub>CC</sub> = 3.3 V ± 5%)

Parameter	Symbol	Logic	Min	Typ	Max	Unit
Parallel Input Clock	PICLK/P/N	Diff. LVPECL	153.90	155.52	157.00	MHz
Parallel Clock in Duty Cycle	—	—	40	—	60	%
Reference Clock Freq. Tolerance	TxREFCLK/P/N	Diff. LVPECL	-20	—	20	ppm
Reference Clock Input Duty Cycle	—	—	30	—	70	%
Reference Clock Rise and Fall Time <sup>1</sup>	t <sub>R</sub> , t <sub>F</sub>	—	—	—	0.5	ns
Reference Clock Signal Levels <sup>2</sup> : Differential Input Signal Level, $\Delta V_{INDIFF}$ Single-ended Input Sig. Level, $\Delta V_{INSINGLE}$ Differential Input Resistance, $\Delta R$	TxREFCLK	Diff. LVPECL	300 150 80	— — 100	1200 600 120	mV mV $\Omega$
Input Data Signal Levels: Input High, V <sub>IH</sub> Input Low, V <sub>IL</sub> Input Voltage Swing, $\Delta V_{IN}$	TxD[0:15]P/N	Diff. LVPECL	V <sub>CC</sub> - 1.2 V <sub>CC</sub> - 2.0 300	— — —	V <sub>CC</sub> - 0.3 V <sub>CC</sub> - 1.5 —	V V mV
Transmitter Disable Input <sup>3</sup>	TxD <sub>IS</sub>	TTL (5 V)	2.0	—	5.0	V
Transmitter Enable Input <sup>3</sup>	TxE <sub>N</sub>	TTL (5 V)	0	—	0.8	V
Wavelength-Select Voltage: Channel N Select, V <sub><math>\lambda</math>N</sub> Channel N - 1 Select, V <sub><math>\lambda</math>N-1</sub>	WS	TTL	0 2.0	— —	0.8 V <sub>CC</sub>	V V
Wavelength Deviation Alarm: Normal Mode, V <sub>N0-ALARM</sub> Wavelength Alarm, V <sub>ALARM</sub> Alarm Setting (active-high) <sup>4</sup>	WDEA	TTL	0 4.5 -100	— — —	0.3 5 100	V V pm
Laser Degrade Alarm: Normal Mode, V <sub>N0-ALARM</sub> Laser Degraded, V <sub>ALARM</sub>	LSRALM	TTL	4.5 0	— —	5 0.3	V V
Laser Power Monitor Output <sup>5</sup>	LPM	Analog	35	500	1000	mV
Phase Initialization: Input High, V <sub>IH</sub> Input Low, V <sub>IL</sub>	PHINIT	LVPECL	V <sub>CC</sub> - 1.0 V <sub>CC</sub> - 2.3	— —	V <sub>CC</sub> - 0.57 V <sub>CC</sub> - 1.44	V V

1. 20% to 80%.

2. Internally biased and ac-coupled.

3. The transmitter is normally enabled and only requires an external voltage to disable.

4. The WDEA alarm becomes active when the optical wavelength deviates from the nominal center wavelength by more than 100 pm.

5. Set at 500 mV at nominal optical output power. Provides linear P<sub>o</sub> tracking (-3 dB = 250 mV, +3 dB = 1000 V).

6. Terminated into 200  $\Omega$  to GND and 100  $\Omega$  line-to-line.



**Electrical Characteristics** (continued)

**Table 7. Transmitter Electrical I/O Characteristics** ( $T_c = 0\text{ }^\circ\text{C}$  to  $65\text{ }^\circ\text{C}$ ,  $V_{CC} = 3.3\text{ V} \pm 5\%$ ) (continued)

Parameter	Symbol	Logic	Min	Typ	Max	Unit
Phase Error <sup>5</sup> : Output High, $V_{OH}$ Output Low, $V_{OL}$	PHERR	LVPECL	$V_{CC} - 1.2$ $V_{CC} - 2.2$	— —	$V_{CC} - 0.65$ $V_{CC} - 1.5$	V V
Line Loopback Enable: Active-low: Input High, $V_{IH}$ Input Low, $V_{IL}$	LLOOP	LVTTTL	2.0 0	— —	$V_{CC} + 1.0$ 0.8	V V
Diagnostic Loopback Enable: Active- low: Input High, $V_{IH}$ Input Low, $V_{IL}$	DLOOP	LVTTTL	2.0 0	— —	$V_{CC} + 1.0$ 0.8	V V
Parallel Output Clock <sup>6</sup> : Output High, $V_{OH}$ Output Low, $V_{OL}$ Differential Voltage Swing, $\Delta V_{DIFF}$ S-E Voltage Swing, $\Delta V_{SINGLE}$	PCLKP/N	Differential LVPECL	$V_{CC} - 1.15$ $V_{CC} - 1.95$ 800 400	— — — —	$V_{CC} - 0.6$ $V_{CC} - 1.45$ 1900 950	V V mV mV

- 20% to 80%.
- Internally biased and ac-coupled.
- The transmitter is normally enabled and only requires an external voltage to disable.
- The WDEA alarm becomes active when the optical wavelength deviates from the nominal center wavelength by more than 100 pm.
- Set at 500 mV at nominal optical output power. Provides linear  $P_o$  tracking ( $-3\text{ dB} = 250\text{ mV}$ ,  $+3\text{ dB} = 1000\text{ V}$ ).
- Terminated into  $200\ \Omega$  to GND and  $100\ \Omega$  line-to-line.

**Table 8. Receiver Electrical I/O Characteristics** ( $T_c = 0\text{ }^\circ\text{C}$  to  $65\text{ }^\circ\text{C}$ ,  $V_{CC} = 3.3\text{ V} \pm 5\%$ )

Parameter	Symbol	Logic	Min	Typ	Max	Unit
Parallel Output Clock: Output High, $V_{OH}$ Output Low, $V_{OL}$	POCLKP/N	Differential LVPECL	$V_{CC} - 1.3$ $V_{CC} - 2.0$	— —	$V_{CC} - 0.7$ $V_{CC} - 1.4$	V V
POCLK Duty Cycle	—	—	40	—	60	%
Output Data Signal Levels <sup>1</sup> : Output High, $V_{OH}$ Output Low, $V_{OL}$	RxQ[0:15]P/N	Differential LVPECL	$V_{CC} - 1.3$ $V_{CC} - 2.0$	— —	$V_{CC} - 0.7$ $V_{CC} - 1.4$	V V
RxQ[0:15] Rise/Fall Time <sup>2</sup>	—	—	—	—	1.0	ns
Frame Pulse: Output High, $V_{OH}$ Output Low, $V_{OL}$	FP	LVPECL	$V_{CC} - 1.3$ $V_{CC} - 2.0$	— —	$V_{CC} - 0.7$ $V_{CC} - 1.4$	V V
Loss-of-Signal Output: Output High, $V_{OH}$ Output Low, $V_{OL}$	LOS	LVTTTL	2.4 0	— —	$V_{CC}$ 0.4	V V
Out-of-Frame Input: Input High, $V_{IH}$ Input Low, $V_{IL}$	OOF	LVTTTL	2.0 0.0	— —	TTL $V_{CC} + 1.0$ 0.8	V V
Frame Enable Input Input High, $V_{IH}$ Input Low, $V_{IL}$	FRAMEN	LVTTTL	2.0 0.0	— —	TTL $V_{CC} + 1.0$ 0.8	V V

- Terminated into  $330\ \Omega$  to ground.
- 20% to 80%,  $330\ \Omega$  to ground.

## Timing Characteristics

### Transmitter Data Input Timing

The CA16 transponder utilizes a unique FIFO to decouple the internal and external (PICKL) clocks. The FIFO can be initialized, which allows the system designer to have an infinite PCLK-to-PICKL delay through this interfacing logic (ASIC or commercial chip set). The configuration of the FIFO is dependent upon the I/O pins, which comprise the synch timing loop. This loop is formed from PHERR to PHINIT and PCLK to PICKL.

The FIFO can be thought of as a memory stack that can be initialized by PHINT or LOCKDET. The PHERR signal is a pointer that goes high when a potential timing mismatch is detected between PICKL and the internally generated PCLK clock. When PHERR is fed back to PHINIT, it initializes the FIFO so that it does not overflow or underflow.

The internally generated divide-by-16 clock is used to clock-out data from the FIFO. PHINIT and LOCKDET signals will center the FIFO after the third PICKL pulse. This is done to ensure that PICKL is stable. This scheme allows the user to have an infinite PCLK to PICKL delay through the ASIC. Once the FIFO is centered, the PCLK and PICKL can have a maximum drift of  $\pm 5$  ns.

During normal operation, the incoming data is passed from the PICKL input timing domain to the internally generated divide-by-16 PCLK timing domain. Although the frequency of PICKL and PCLK is the same, their phase relationship is arbitrary. To prevent errors caused by short setup or hold times between the two domains, the timing generator circuitry monitors the phase relationship between PICKL and PCLK.

When an FIFO timing violation is detected, the phase error (PHERR) signal pulses high. If the condition persists, PHERR will remain high. When PHERR is fed back into the PHINIT input (by shorting them on the printed-circuit board [PCB]), PHINIT will initialize the FIFO if PHINIT is held high for at least two byte clocks. The initialization of the FIFO prevents PCLK and PICKL from concurrently trying to read and write over the same FIFO bank.

During realignment, one-to-three bytes (16 bits wide) will be lost. Alternatively, the customer logic can take in the PHERR signal, process it, and send an output to the PHINIT input in such a way that only idle bytes are lost during the initialization of the FIFO. Once the FIFO has been initialized, PHERR will go inactive.

**Timing Characteristics** (continued)

**Input Timing Mode 1**

In the configuration shown in Figure 5, PHERR to PHINIT has a zero delay (shorted on the PCB) and the PCLK is used to clock 16-bit-wide data out of the customer ASIC. The FIFO in the multiplexer is 16-bits wide and six registers deep.

The PCLK and PCLK signals respectively control the READ and WRITE counters for the FIFO. The data bank from the FIFO has to be read by the internally generated clock (PCLK) only once after it has been written by the PCLK input.

Since the delay in the customer ASIC is unknown, the two clocks (PCLK and PCLK) might drift in respect to each other and try to perform the read and writer operation on the same bank in the FIFO at the same time. However, before such a clock mismatch can occur, PHERR goes high and, if externally connected to PHINIT, will initialize the FIFO provided PHINIT remains high for at least two byte clocks. One to three 16-bit words of data will be lost during the initialization of the FIFO.

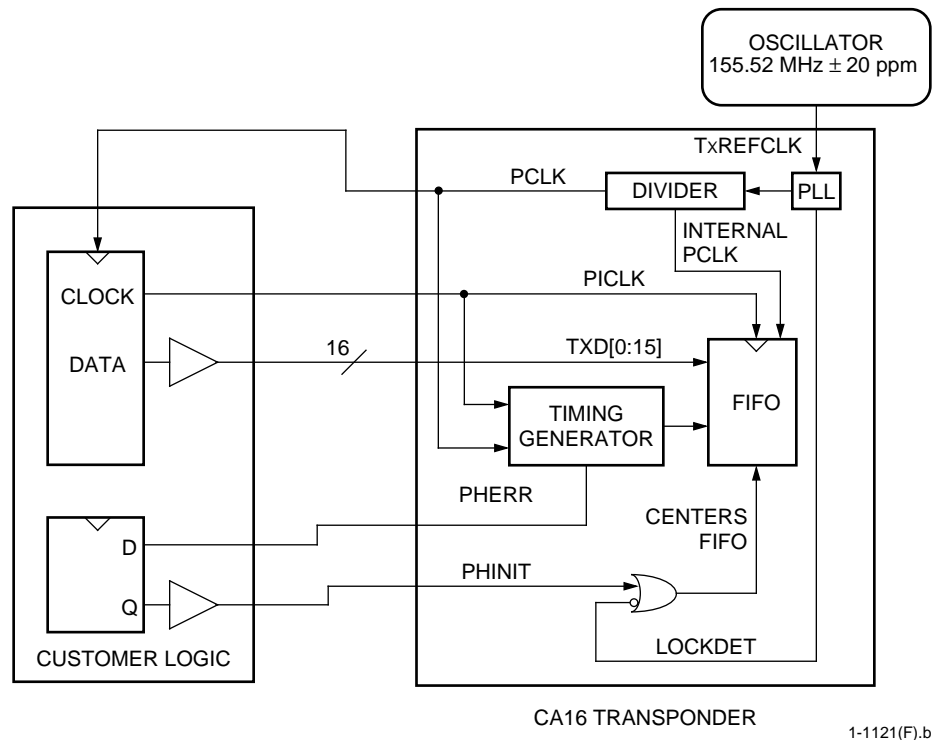

**Figure 5. Block Diagram Timing Mode 1**

**Transmitter Data Input Timing** (continued)

**Input Timing Mode 2**

To avoid the loss of data, idle or dummy bytes should be sent on the TxD[0:15] bus whenever PHERR goes high. In the configuration shown in Figure 6, the PHERR signal is used as an input to the customer logic. Upon detecting a high on the PHERR signal, the customer logic should return a high signal, one that remains high for at least two byte-clock cycles, to the PHINIT input of the CA16. Also, when PHERR goes high, the customer logic should start sending idle or

dummy bytes to the CA16 on the TxD[0:15] bus. This should continue until PHERR goes low.

The FIFO is initialized two-to-eight byte clocks after PHINIT goes high for two byte clocks. PHERR goes low after the FIFO is initialized. Upon detecting a low on PHERR, the customer logic can start sending real data bytes on TxD[0:15]. The two timing loops (PCLK to PCLK and PHERR to PHINIT) do not have to be of equal length.

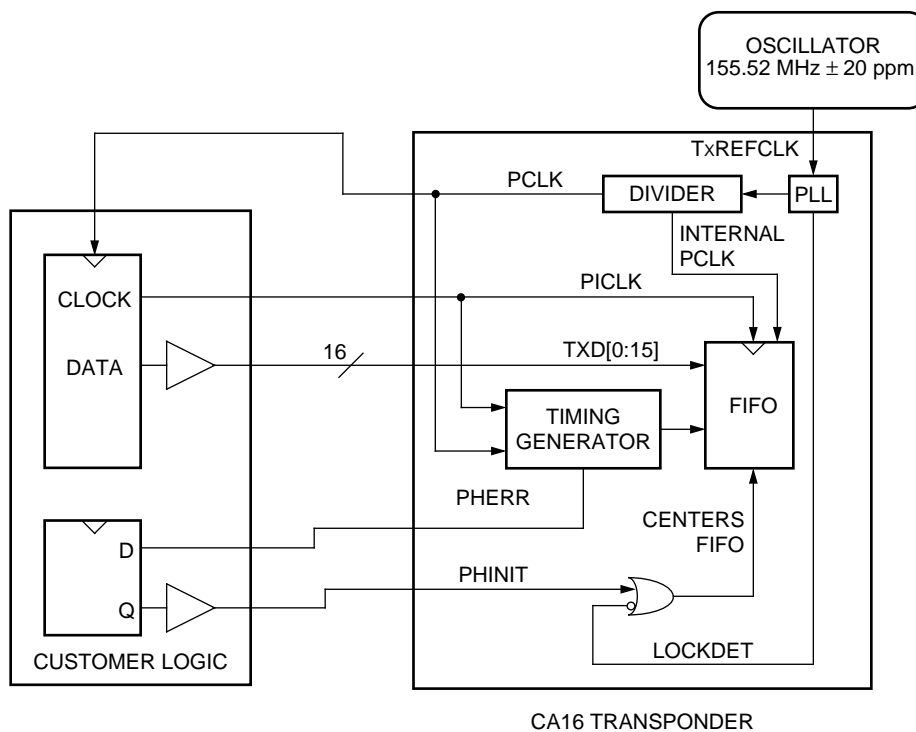

1121(F).b

**Figure 6. Block Diagram Timing Mode 2**

**Timing Characteristics** (continued)

**Forward Clocking**

In some applications, it is necessary to forward-clock the data in a SONET/SDH system. In this application, the reference clock from which the high-speed serial clock is synthesized and the parallel data clock both originate from the same source on the customer application circuit. The timing control logic in the CA16 transponder transmitter automatically generates an internal load signal that has a fixed relationship to the reference clock. The logic takes into account the variation of the

reference clock to the internal load signal over temperature and voltage. The connections required to implement this clocking method are shown in Figure 7. The setup and hold times for PICLK to TxD[0:15] must be met by the customer logic.

Possible problems: to meet the jitter generation specifications required by SONET/SDH, the jitter of the reference clock must be minimized. It could be difficult to meet the SONET jitter generation specifications using a reference clock generated from the customer logic.

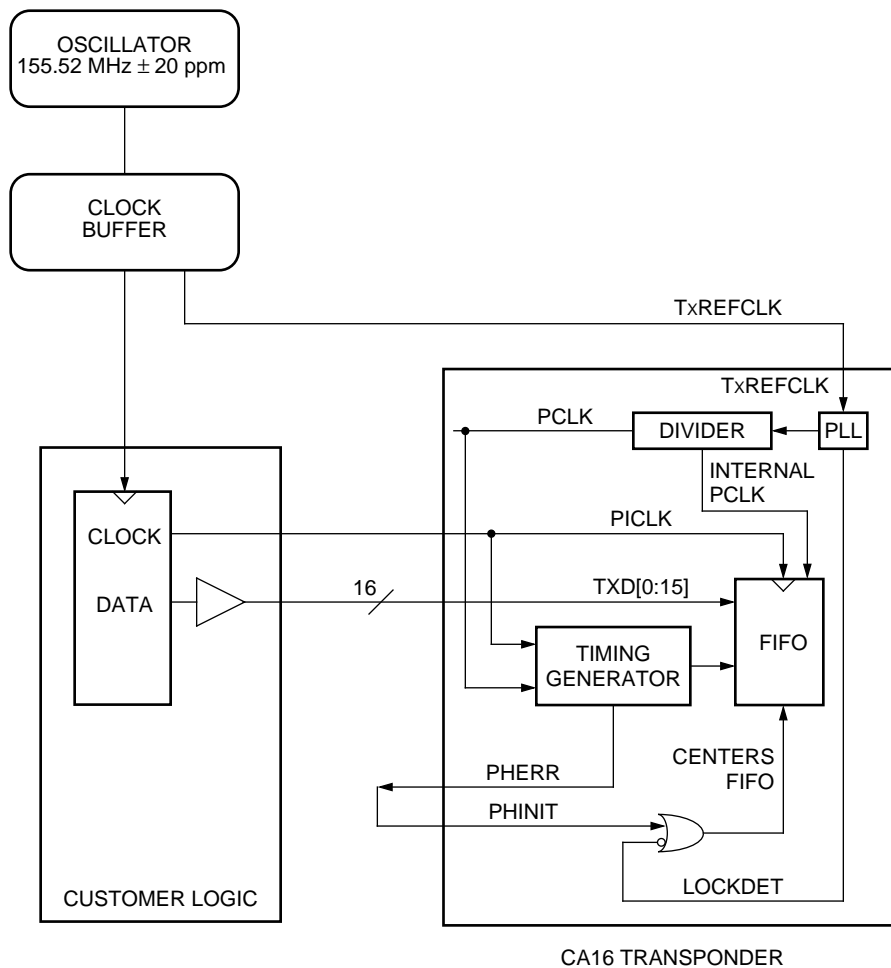

**Figure 7. Forward Clocking of the CA16 Transponder**

1-1122(F).a

**Timing Characteristics** (continued)

**PCLK-to-PICLK Timing**

After powerup or RESET, the LOCKDET signal will go active, signifying that the PLL has locked to the clock provided on the TXREFCLK input. The FIFO is initialized

on the third PICLK after LOCKDET goes active. The PCLK-to-PICLK delay ( $t_D$ ) can have any value before the FIFO is initialized. The  $t_D$  is fixed at the third PICLK after LOCKDET goes active. Once the FIFO is initialized, PCLK and PICLK cannot drift more than 5.2 ns;  $t_{CH}$  cannot be more than 5.2 ns.

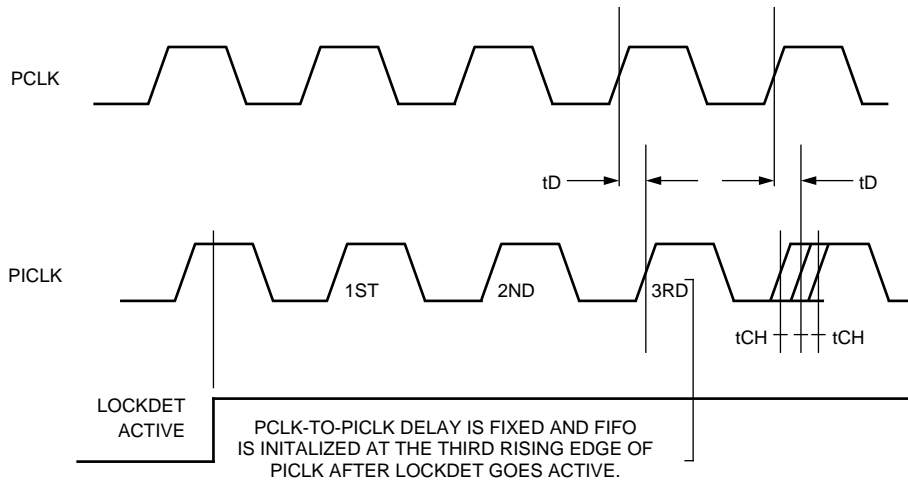

**Figure 8. PCLK-to-PICLK Timing**

1-1123(F)

**Timing Characteristics** (continued)

**PHERR/PHINIT**

Case 1— PHERR and PHINIT are shorted on the printed-circuit board:

PHINIT would go high whenever there is a potential timing mismatch between PCLK and PICLK. PHINIT would remain high as long as the timing mismatch between PCLK and PICLK. If PHINIT is high for more than two byte clocks, the FIFO will be initialized. PHINIT will initialize the FIFO two-to-eight byte clocks after it is high for at least two byte clocks, PHERR (and thus PHINIT) goes active once the FIFO is initialized.

Case 2—PHERR signal is input to the customer logic and the customer logic outputs a signal to PHINIT:

Another possible configuration is where the PHERR signal is input into the customer logic and the customer logic sends an output to the PHINIT input. However, the customer logic must ensure that, upon detecting a high on PHERR, the PHINIT signal remains high for more than two byte clocks. If PHINIT is high for less than two byte clocks, the FIFO is not guaranteed to be initialized. Also, the customer logic must ensure that PHINIT goes low after the FIFO is initialized (PHERR goes low).

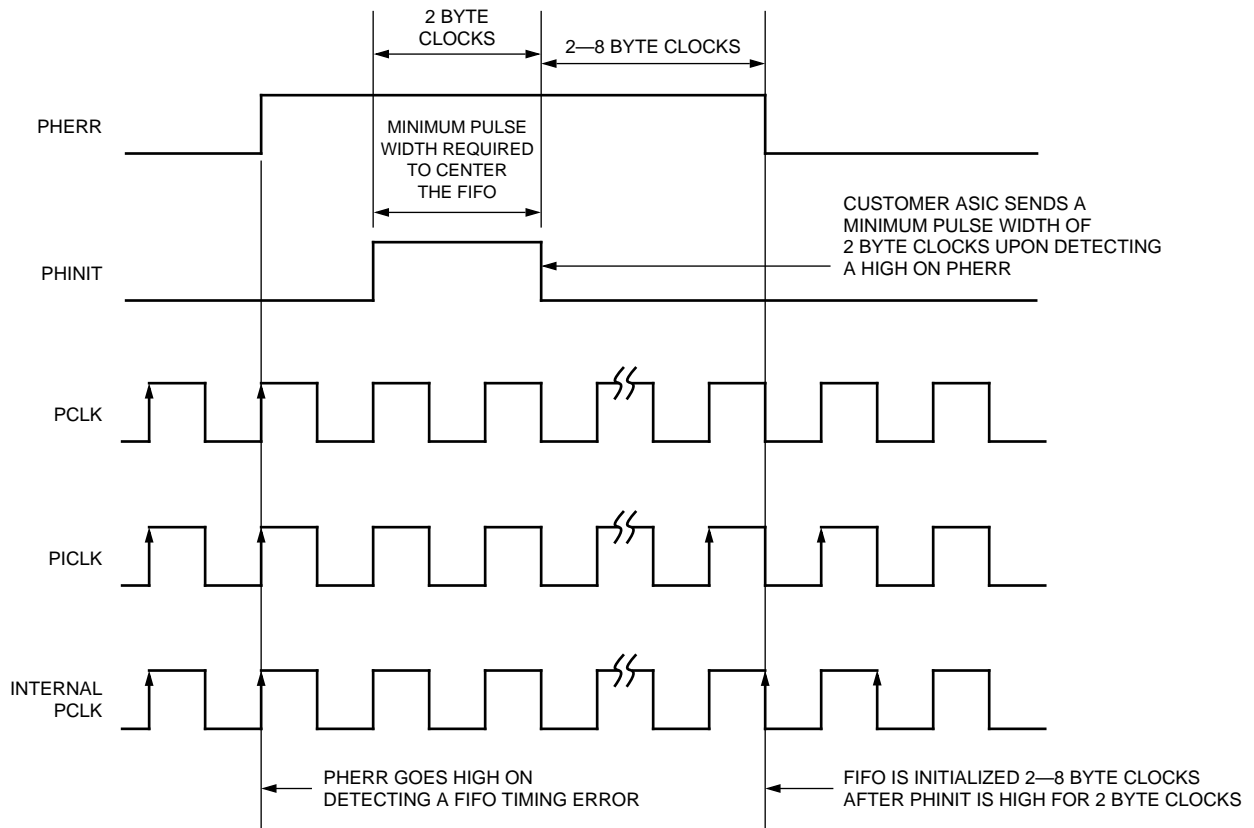

**Figure 9. PHERR/PHINIT Timing**

1125(F)

**Timing Characteristics** (continued)

**Transmitter Data Input Timing** (continued)

**Table 9. Transmitter ac Timing Characteristics**

Symbol	Description	Min	Max	Unit
tSTxD	TxD[0:15] Setup Time w. r. t. PCLK	1.5	—	ns
tHTxD	TxD[0:15] Hold Time w. r. t. PCLK	0.5	—	ns
—	PCLKP/N Duty Cycle	40	55	%
—	PICLKP/N Duty Cycle	40	60	%
tPPICLK	PICLK-to-PICLK Drift After FIFO Centered	—	5	ns

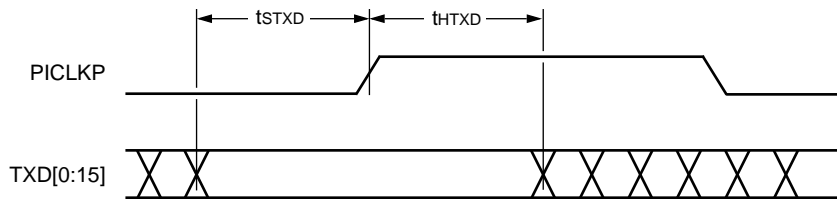
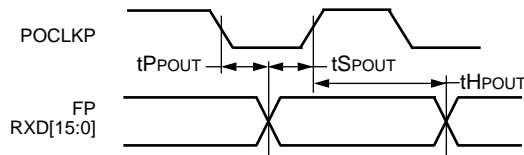

**Figure 10. ac Input Timing**

**Table 10. Receiver ac Timing Characteristics**

Symbol	Description	Min	Max	Unit
—	POCLK Duty Cycle	45	55	%
—	RxD[15:0] Rise and Fall Time <sup>1</sup>	—	1.0	ns
tPPOUT	POCLK Low to RxD[15:0] Valid Propagation Delay	-1	1	ns
tSPOUT	RxD[15:0] and FP Setup Time w. r. t. POCLK	2	—	ns
tHPOUT	RxD[15:0] and FP Hold Time w. r. t. POCLK	2	—	ns

1. 20% to 80%; 330 Ω to GND.



**Figure 11. Receiver Output Timing Diagram**



**Timing Characteristics** (continued)

**Receiver Framing**

**Note: Future versions of the cooled transponder will not support the frame-detect function.**

Figure 12 shows a typical reframe sequence in which a byte realignment is made. The frame and byte boundary detection is enabled by the rising edge of OOF. Both the frame and byte boundaries are recognized upon receipt of the first A2 byte following three consecutive A1 bytes. The third A2 byte is the first data byte to be reported with the correct byte alignment on the out-

going data bus (RxD[15:0]). Concurrently, the frame pulse (FP) is set high for one POCLK cycle.

The frame and byte boundary detection block is activated by the rising edge of OOF and stays active until the first FP pulse.

Figure 13 shows the frame and byte boundary detection activation by a rising edge of OOF and deactivation by the first FP pulse.

Figure 14 shows the frame and byte boundary detection by the activation of a rising edge of OOF and deactivation by the FRAMEN input.

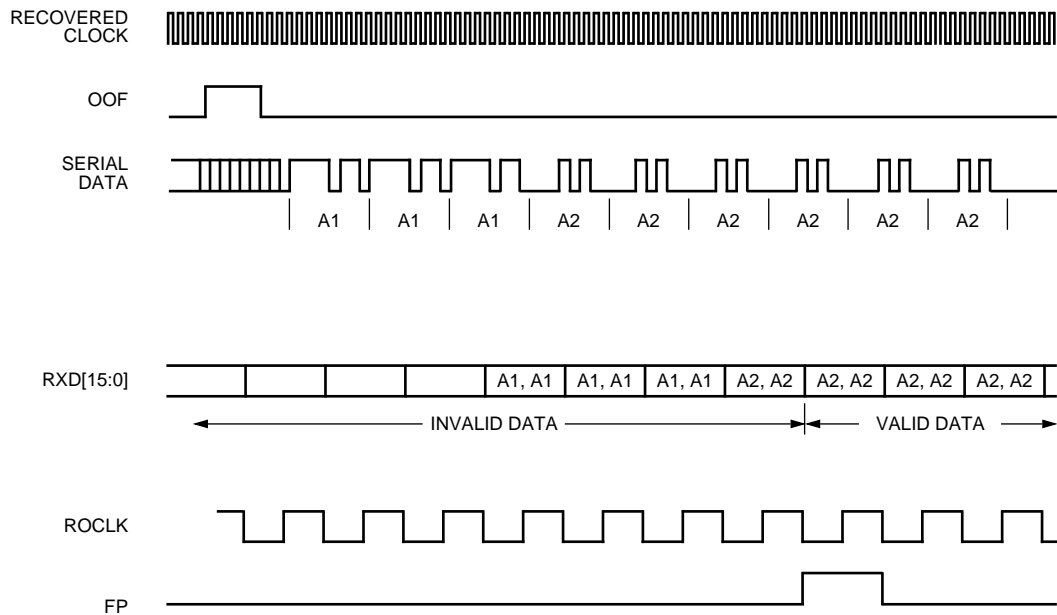

1-1023(F)r.3

**Figure 12. Frame and Byte Detection**

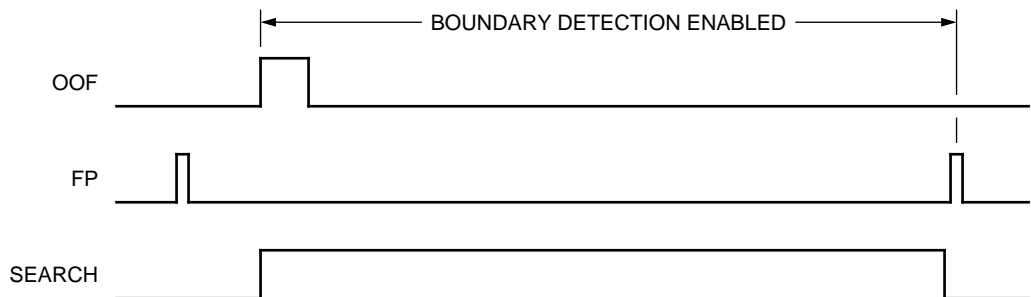

1-1024(F)

**Figure 13. OOF Timing (FRAMEN = High)**

**Timing Characteristics** (continued)

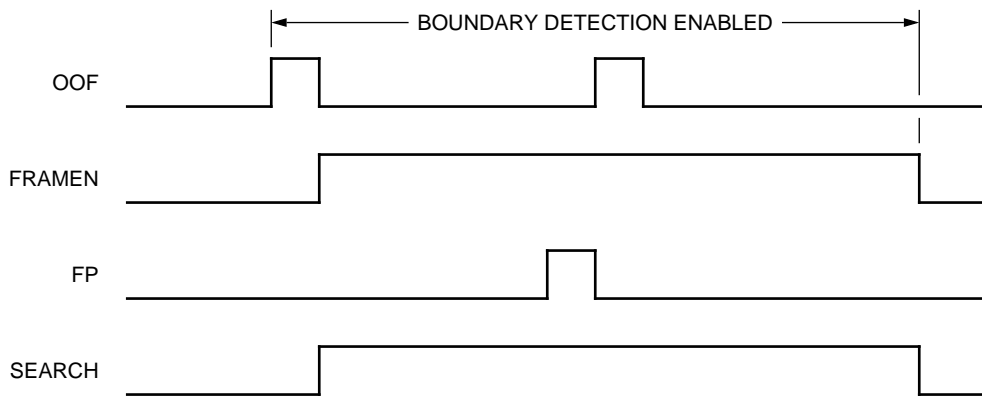

1-1025(F)

**Figure 14. FRAMEN Timing**

**Wavelength Selection**

When the wavelength select (WS) pin is at a logic low or open circuited, the optical wavelength from the CA16 transmitter will be a nominal wavelength as determined by the device code purchased. If the WS pin is pulled high (logic 1), the optical wavelength will change to the next lower ITU channel number (100 GHz spacing,  $\lambda$  will increase approximately 0.8 nm).

During the wavelength change, the transmitter's optical output will be disabled and the wavelength deviation error alarm will be active until the wavelength has stabilized at its new value. The LSRALM will also be active (logic 1) during the wavelength change process.

## Qualification and Reliability

To help ensure high product reliability and customer satisfaction, Lucent is committed to an intensive quality program that starts in the design phase and proceeds through the manufacturing process. Optoelectronics modules are qualified to Lucent internal standards using MIL-STD-883 test methods and procedures and using sampling techniques consistent with *Telcordia Technologies*\* requirements. This qualification program fully meets the intent of *Telcordia Technologies* reliability practices TR-NWT-000468 and TA-TSY-000983. In addition, the Lucent Technologies Microelectronics Group Optoelectronics design, development, and manufacturing facility has been certified to be in full compliance with the latest *ISO*<sup>†</sup> 9001 Quality System Standards.

\* *Telcordia Technologies* is a trademark of Telcordia Technologies, Inc.

† *ISO* is a registered trademark of The International Organization for Standardization.

## Laser Safety Information

### Class I Laser Product

All versions of the CA16-type transponders are classified as Class I laser products per FDA/CDRH, 21 CFR 1040 Laser Safety requirements. The transponders have been registered/certified with the FDA under accession number 8720009. All versions are classified as Class I laser products per *IEC*<sup>‡</sup> 825-1:1993, A1:1997, and A2:2001.

**CAUTION: Use of controls, adjustments, and procedures other than those specified herein may result in hazardous laser radiation exposure.**

This product complies with 21 CFR 1040.10 and 1040.11.

8.8  $\mu\text{m}$  single-mode pigtail with connector.

Wavelength = 1.5  $\mu\text{m}$ .

Maximum power = 2.0 mW.

Product is not shipped with power supply.

Because of size constraints, laser safety labeling is not affixed to the module but is attached to the outside of the shipping carton.

### NOTICE

**Unterminated optical connectors can emit laser radiation.**

**Do not view with optical instruments.**

## Electromagnetic Emissions and Immunity

The CA16 transponder will be tested against CENELEC EN50 081 part 1 and part 2, FCC 15, Class B limits for emissions.

The CA16 transponder will be tested against CENELEC EN50 082 part 1 immunity requirements.

‡ *IEC* is a registered trademark of The International Electrotechnical Commission.

## Outline Diagram

Dimensions are in inches and (millimeters) (for initial samples; production version will be slightly smaller).

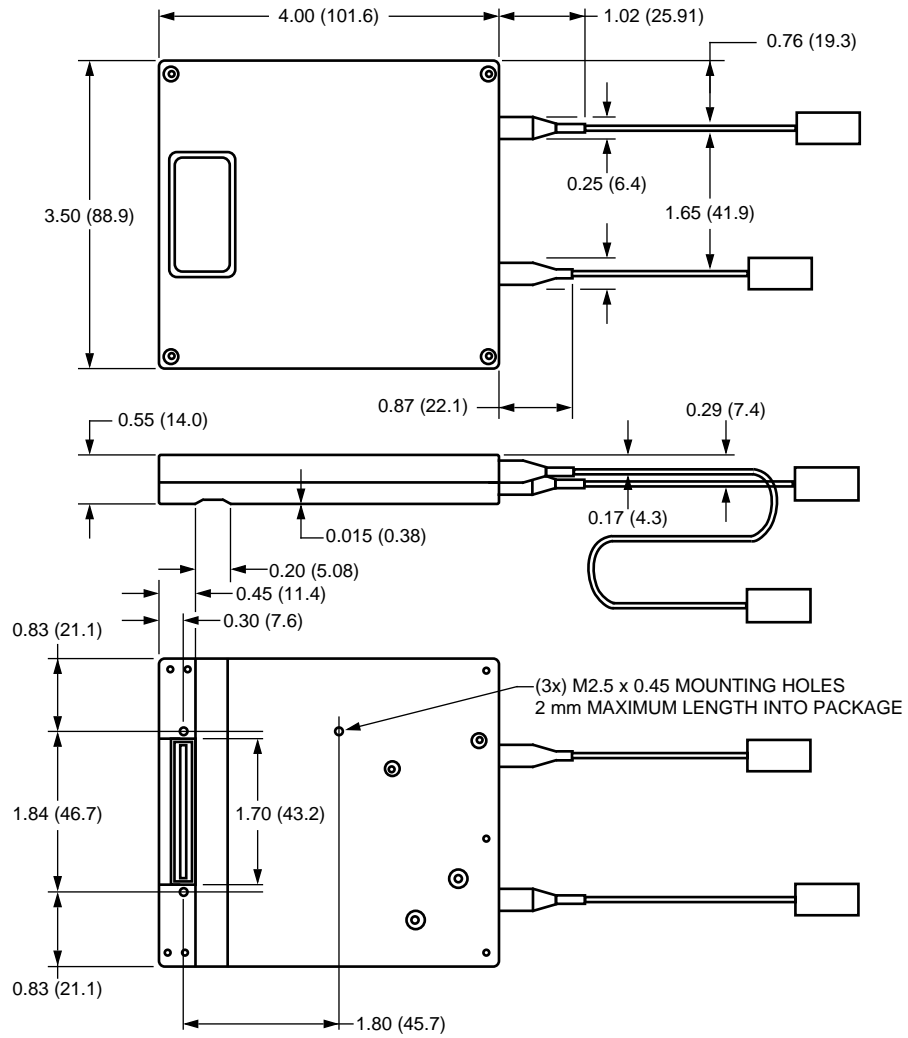

1-1103(F)

## Ordering Information

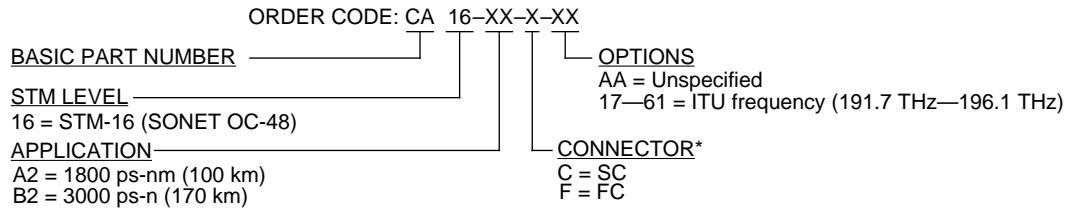

\* Other connectors may be made available.

**Table 11. Ordering Information**

Code	Application	Connector	Comcode
CA16A2CAA	Unspecified wavelength (1800 ps-nm)	SC	108701475
CA16A2FAA	Unspecified wavelength (1800 ps-nm)	FC/PC	108701483
CA16A2Cnn	Specified wavelength (1800 ps-nm)	SC	—†
CA16A2Fnn	Specified wavelength (1800 ps-nm)	FC/PC	—†
CA16B2CAA	Unspecified wavelength (3000 ps-nm)	SC	108701491
CA16B2FAA	Unspecified wavelength (3000 ps-nm)	FC/PC	108701509
CA16B2Cnn	Specified wavelength (3000 ps-nm)	SC	—†
CA16B2Fnn	Specified wavelength (3000 ps-nm)	FC/PC	—†

† For specific order codes for these products, please contact your local Lucent account manager.

## Related Product Information

**Table 12. Related Product Information**

Description	Document Number
<i>Using the Lucent Technologies Transponder Test Board Application Note</i>	AP00-017OPTO

---

For additional information, contact your Agere Systems Account Manager or the following:

INTERNET: <http://www.agere.com>

E-MAIL: [docmaster@micro.lucent.com](mailto:docmaster@micro.lucent.com)

N. AMERICA: Agere Systems Inc., 555 Union Boulevard, Room 30L-15P-BA, Allentown, PA 18109-3286  
**1-800-372-2447**, FAX 610-712-4106 (In CANADA: **1-800-553-2448**, FAX 610-712-4106)

ASIA PACIFIC: Agere Systems Singapore Pte. Ltd., 77 Science Park Drive, #03-18 Cintech III, Singapore 118256  
**Tel. (65) 778 8833**, FAX (65) 777 7495

CHINA: Agere Systems (Shanghai) Co., Ltd., 33/F Jin Mao Tower, 88 Century Boulevard Pudong, Shanghai 200121 PRC  
**Tel. (86) 21 50471212**, FAX (86) 21 50472266

JAPAN: Agere Systems Japan Ltd., 7-18, Higashi-Gotanda 2-chome, Shinagawa-ku, Tokyo 141, Japan  
**Tel. (81) 3 5421 1600**, FAX (81) 3 5421 1700

EUROPE: Data Requests: DATALINE: **Tel. (44) 7000 582 368**, FAX (44) 1189 328 148  
Technical Inquiries: OPTOELECTRONICS MARKETING: **(44) 1344 865 900** (Ascot UK)

---

Agere Systems Inc. reserves the right to make changes to the product(s) or information contained herein without notice. No liability is assumed as a result of their use or application. No rights under any patent accompany the sale of any such product(s) or information. *Translight* is a trademark of Agere Systems Inc.

